



D

MITSUBISHI TRANSISTORIZED INVERTER

HIGH FUNCTION & LOW ACOUSTIC NOISE

FREQROL[®] A₂₀₀

FR-A₂₂₀-0.4K(P)~55K

FR-A₂₄₀-0.4K(P)~55K

— INSTRUCTION MANUAL —

US VERSION



PARAMETER SETTING LIST

This sheet is provided for your convenience to read, write and record your inverter parameter setting values. Attach the peel off labels on the front of the inverter or any other flat surface.

*CAUTION: Do not place on the inside of the inverter due to the high temperatures generated.

PARAMETER SETTINGS (FR-A200)

Parameter Number	Name	Setting range	Factory Setting	User Setting
0	Torque boost (Manual)	0 to 30%	6/3 Note1	
1	Max. frequency	0 to 120 Hz	120Hz	
2	Min. frequency	0 to 120 Hz	0Hz	
3	Base frequency	0 to 400 Hz	60Hz	
4	3-speed setting (High)	0 to 400 Hz	60Hz	
5	3-speed setting (Med)	0 to 400 Hz	30Hz	
6	3-speed setting (Low)	0 to 400 Hz	10Hz	
7	Acceleration time	0 to 3600/360sec	5/15 Note2	
8	Deceleration time	0 to 3600/360sec	5/15 Note2	
9	Electronic thermal relay	0 to 500A	Rated Current	
10	DC brake frequency	0 to 120Hz	3Hz	
11	DC brake time	0 to 10sec	0.5sec	
12	DC brake voltage	0 to 30%	6/3 Note1	
13	Starting frequency	0 to 60Hz	0.5Hz	
14	Applied load selection	0, 1, 2, 3	0	
15	Jog frequency	0 to 400Hz	5Hz	
16	Jog acc./dec. time	0 to 3600/360sec	0.5sec	
17	External thermal select	0, 1, 2, 3	0	
18	High-speed freq. limit	120 to 400Hz	120Hz	
19	Base frequency voltage	0 to 1000V, 9999	9999	
20	Acc./Dec. ref. frequency	1 to 400Hz	60Hz	
21	Acc./Dec. time unit	0, 1	0	
22	Stall prevent. level 1	0 to 200%	150%	
23	Stall prevent. level 2	0 to 200%, 9999	9999	
24	Multi-speed setting 4	0 to 400Hz, 9999	9999	
25	Multi-speed setting 5	0 to 400Hz, 9999	9999	
26	Multi-speed setting 6	0 to 400Hz, 9999	9999	
27	Multi-speed setting 7	0 to 400Hz, 9999	9999	
28	Multi-speed compensa.	0, 1	0	
29	Acc./Dec. pattern	0, 1, 2, 3	0	
30	Ext. brake resistor	0, 1	0	
31	Frequency jump 1A	0 to 400Hz/9999	9999	
32	Frequency jump 1B	0 to 400Hz/9999	9999	
33	Frequency jump 2A	0 to 400Hz/9999	9999	
34	Frequency jump 2B	0 to 400Hz/9999	9999	
35	Frequency jump 3A	0 to 400Hz/9999	9999	
36	Frequency jump 3B	0 to 400Hz/9999	9999	
37	Speed display	2 to 9998	4	
38	Torque boost (Auto.)	0 to 200%	0	
39	Auto. torque boost Cur.	0 to 500A	0	
40	Output terminal assign.	0 to 9999	1234	

Note 1: 6% for 7.5k or less, 3% for 11k or more.

Note 2: 5sec for 7.5k or less, 15sec for 11k or more.

rpm rpm r/min r/min V V
A A Hz Hz kW kW

m³/min m³/min l/min l/min m/min m/min
% % x0.1 x0.1 x0.01 x0.01

PARAMETER SETTINGS (FR-A200)

Parameter Number	Name	Setting range	Factory Setting	User Setting
41	"SU" sensitivity	0 to 100%	10%	
42	"FU1" detecting level 1	0 to 400Hz	6Hz	
43	"FU1" detecting level 2	0 to 400Hz, 9999	9999	
44	2nd acceleration time	0 to 3600/360sec	5sec	
45	2nd deceleration time	0 to 3600/360, 9999	9999	
46	2nd torque boost(man.)	0 to 30%, 9999	9999	
47	2nd V/F base frequency	0 to 400Hz, 9999	9999	
48	2nd stall current level	0 to 200%	150%	
49	2nd stall frequency level	0 to 400Hz	0Hz	
50	2nd frequency detection	0 to 400Hz	30Hz	
51	LED display selection	1 to 14, 17, 18	1	
52	PU main display select.	0, 17 to 20	0	
53	PU level display select.	0 to 3, 5 to 14, 17, 18	1	
54	FM function selection	1 to 3, 5 to 14, 17, 18, 21, 101 to 103, 105 to 114, 117, 118, 121	1	
55	Frequency monitor ref.	0 to 400Hz	60Hz	
56	Current monitor ref.	0 to 500A	Rated Current	
57	Restart coasting time	0 to 5sec, 9999	9999	
58	Restart cushion time	0 to 5sec	0.5sec	
59	Remote setting selection	0, 1, 2	0	
60	Intelligent mode select.	0 to 6	0	
66	Stall prev. reduction f	0 to 400Hz	60Hz	
67	Number of retries	0 to 10	0	
68	Retry waiting time	0 to 10sec, 9999	9999	
69	Retry count erasure	0	0	
70	Special brake factor	0 to 15/0 to 30/0 %	0	
71	Applied motor selection	0, 1, 2	0	
72	PWM frequency select.	2 to 14.5kHz	14.5kHz	
73	0 to 5V, 0 to 10V select.	0 to 5, 10 to 15	1	
74	Input filter constant	0 to 8	1	
75	Reset selection	0, 1, 2, 3	0	
76	Alarm code selection	0, 1, 2, 3	0	
77	Parameter write disable	0, 1, 2	0	
78	Reverse prevention	0, 1, 2	0	
79	Operation mode select	0 to 5	0	
80	Motor capacity	0.4 to 55kW, 9999	9999	
81	Number of motor poles	2 to 6, 9999	9999	
900	FM calibration	---	---	
901	AM calibration	---	---	
902	Frequency set. V bias	0 to 10V 0 to 60Hz	0V 0Hz	
903	Frequency set. V gain	0 to 10V 1 to 400Hz	5V 60Hz	
904	Frequency set. I bias	0 to 20mA 0 to 60Hz	4mA 0Hz	
905	Frequency set. I gain	0 to 20mA 1 to 400Hz	20mA 60Hz	

MONITORING MODE LABELS

These labels can be used to indicate (in engineering units) motor rotating speed or conveyor speed, etc.. Place on inverter as shown.

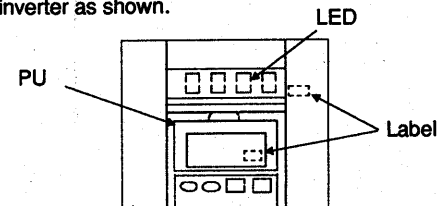

CONTENTS

CONTENTS

PRECAUTIONS FOR HANDLING THE INVERTER

1. ACCEPTANCE INSPECTION.....	1
2. STRUCTURE	2
2.1 Structure.....	2
2.2 Removal and Reinstallation of the Front Cover	3
2.3 Removal and Reinstallation of the Parameter Unit.....	4
2.4 Removal and Reinstallation of the Accessory Cover.....	4
2.5 Handling of the FR-PU01E Parameter Unit.....	5
2.6 Handling of the FR-ZRWE Parameter Copy Unit.....	5
3. INSTALLATION.....	7
3.1 Transportation.....	7
3.2 Place of Installation	7
3.3 Installation Direction and Clearances	8
4. WIRING	9
4.1 Wiring Instructions	9
4.2 Main Circuit	11
4.3 Control Circuit	15
5. OPERATION.....	17
5.1 Operation Mode	17
5.2 Pre-Operation Checks	17
5.3 Pre-Operation Settings.....	18
5.4 Check Points during Test Run	20
6. PARAMETER UNIT.....	22
6.1 Structure of the Parameter Unit	22
6.2 Installation of the Parameter Unit	23
6.3 Functions of the Parameter Unit	26
6.4 Operation.....	28
• Running the Motor from the Parameter Unit	28
• Changing the Monitor Screen	32
• Changing or Checking the Function (Parameter) Set Values	36
• Applying the Help Function	38
• Calibrating the Frequency Meter.....	48
• Adjusting the Bias and Gain of the Frequency Setting Signal	50
6.5 Parameters.....	52
• Parameter List.....	52
• Explanation of the Parameters.....	56
• 5-Point Flexible v/f Characteristic.....	72
• PU Disconnection Detection Function.....	74
• Magnetic Flux Vector Control.....	75
• V/F Slip Control.....	77
• Switch-over Function	78

CONTENTS

7. MAINTENANCE AND INSPECTION	79
7.1 Precautions for Maintenance and Inspection	79
7.2 Check Items	79
7.3 Measurement of Main Circuit Voltages, Currents and Powers.....	82
7.4 Checking the Inverter and Converter Modules	84
7.5 Replacement of Parts	85
8. TROUBLESHOOTING.....	86
8.1 Clearing Up the Cause of Fault	86
8.2 Faults and Check Points.....	87
8.3 Protective Functions	88
8.4 Alarm Code Output	90
9. OPTIONS	91
9.1 Option List	91
9.2 Inboard Dedicated Options.....	93
9.3 External Dedicated Options.....	96
10. SPECIFICATIONS	99
10.1 Standard Specifications	99
10.2 Block Diagram.....	103
10.3 Terminals.....	104
10.4 Terminal Block Arrangement.....	106
10.5 Outline Drawings.....	110
10.6 FR-PU02(E) Parameter Unit Dimension Diagram.....	112
10.7 Peripheral Device List.....	113
10.8 Selecting the Rated Sensitivity Current for the Earth Leakage Circuit Breaker	114
11. APPENDIX	115
11.1 Countermeasures for Noise	115
11.2 Leakage currents	116

PRECAUTIONS FOR HANDLING THE INVERTER

Incorrect handling might cause the inverter to operate improperly, its life to be reduced considerably, and in the worst case, the inverter to be damaged.

Please handle the inverter properly in accordance with the information on each section as well as the precautions and instructions of this manual.

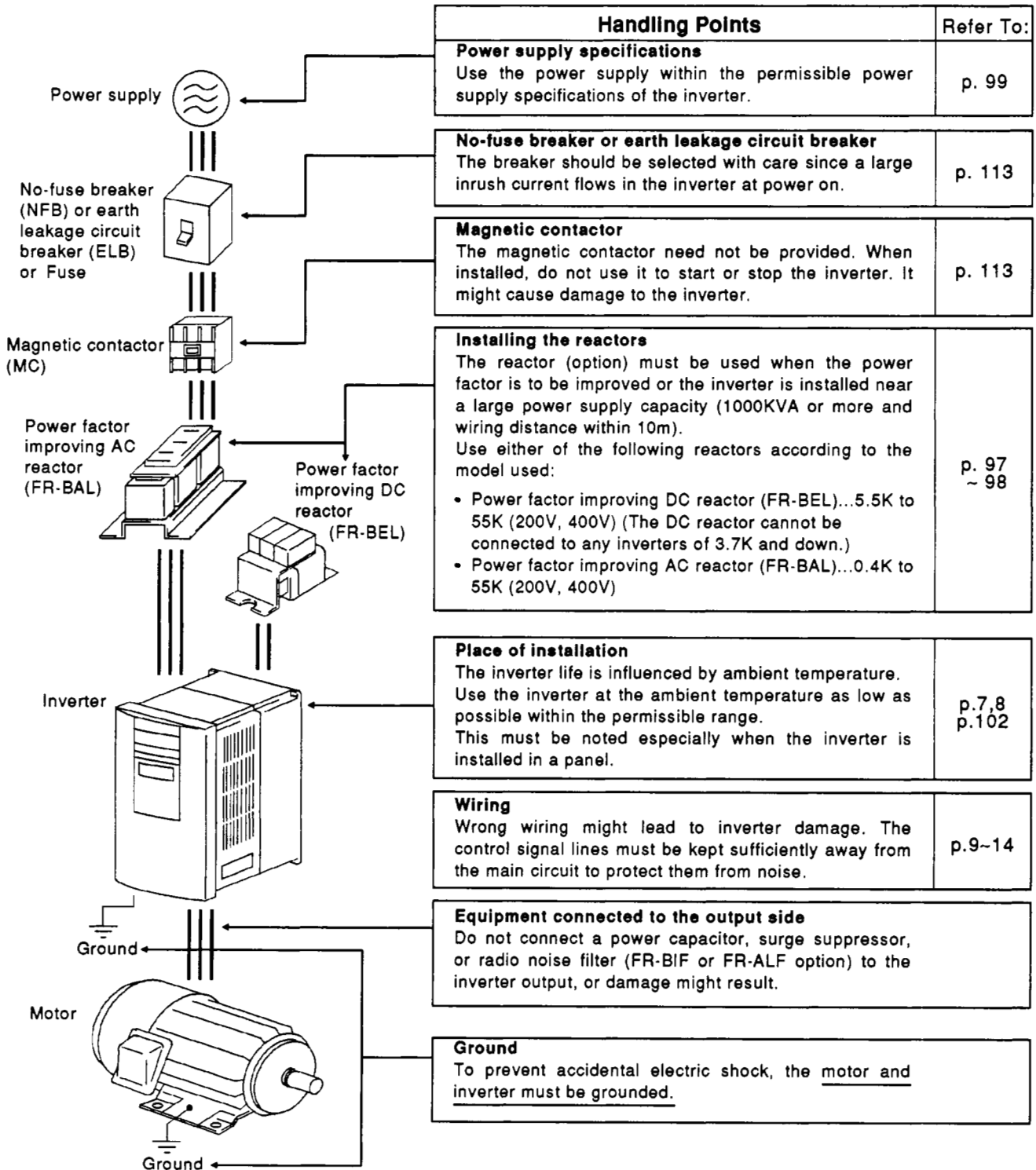

1. ACCEPTANCE INSPECTION

Unpack and check the following:

- (1) Check the capacity plate on the inverter front cover and the rating plate on the inverter side face, and ensure that the type and output rating agree with your order.
- (2) Check for damage in transit.

If you have found any discrepancy, damage, etc., please contact your sales representative.

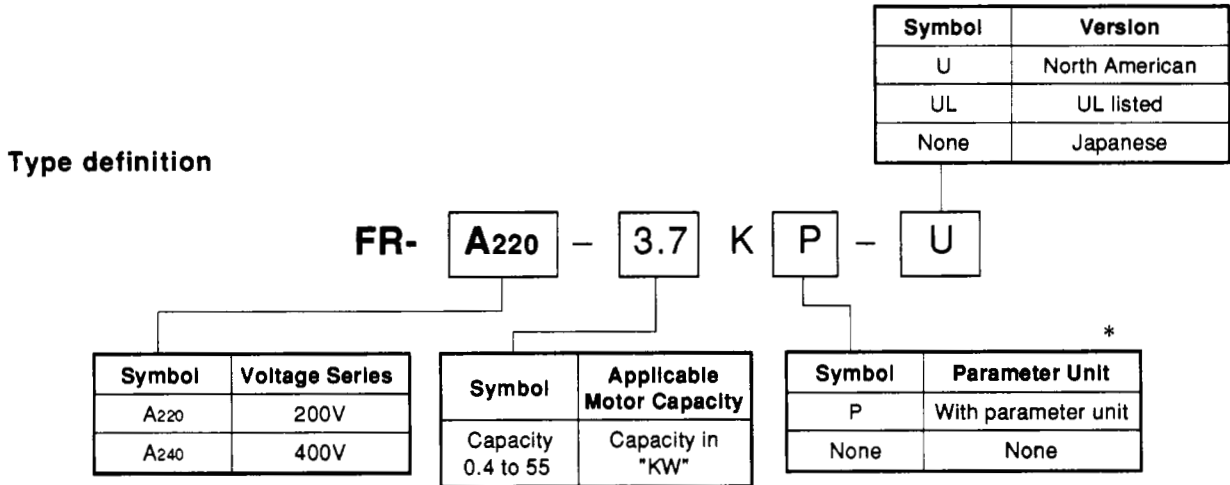
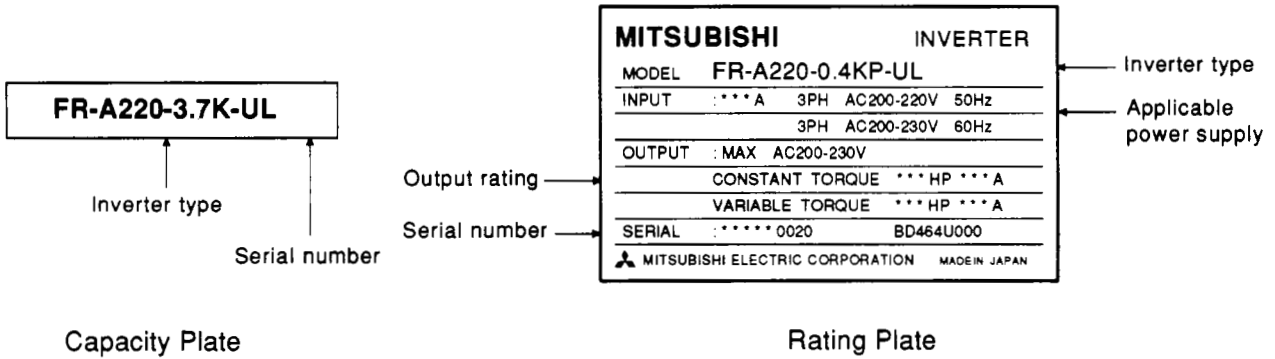

- Inverters 11K and up are not equipped with the parameter unit as standard. For these models, the parameter unit is available as an option.

2. STRUCTURE

2.1 Structure

(Note: For the position of the charge lamp, see the terminal block arrangement diagram on P.106,107.)

FR-A220-0.4K(P) to 7.5K(P),FR-A240-0.4K(P) to 7.5K(P)

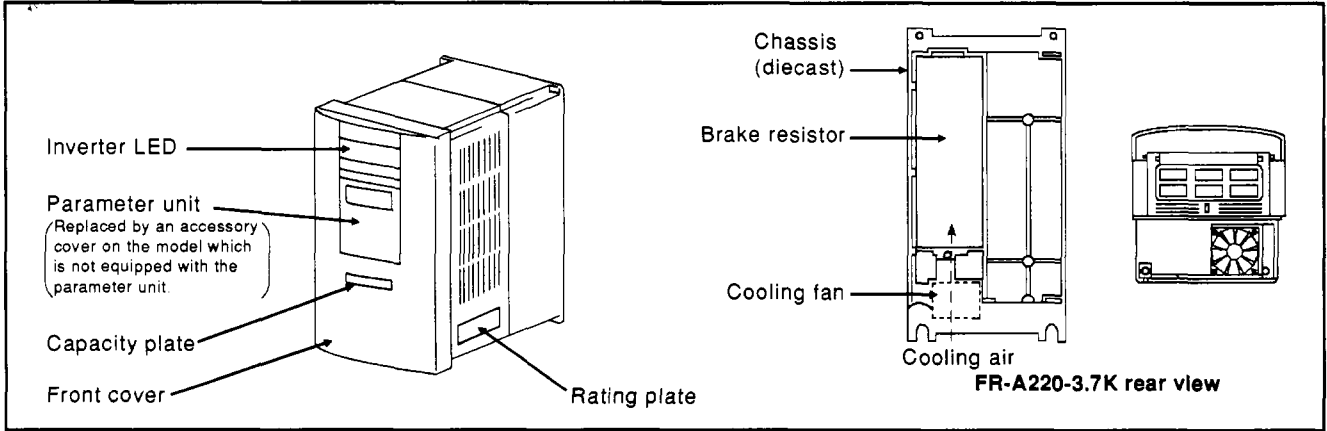

FR-A220-11K to 22K,FR-A240-11K to 22K

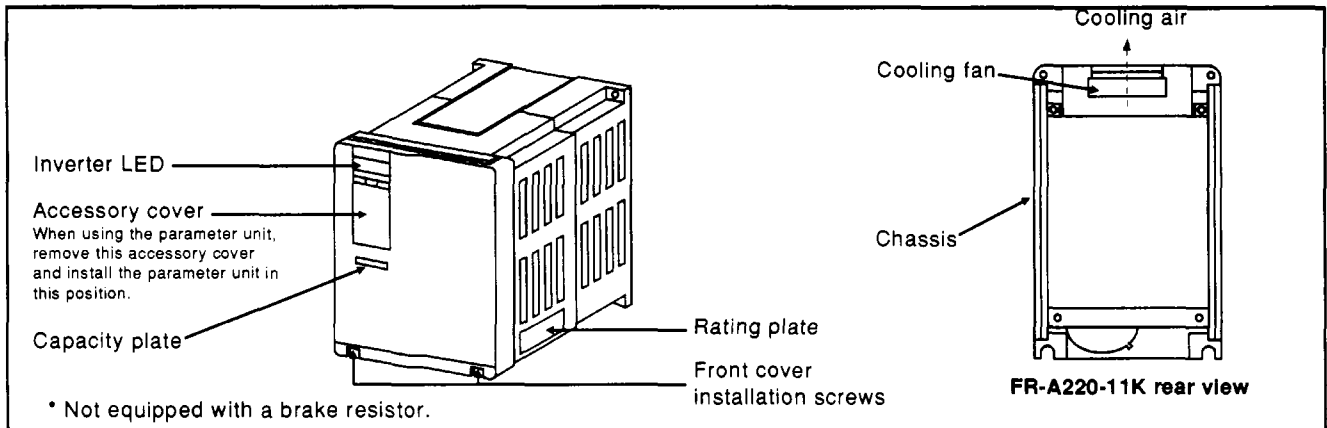

FR-A220-30K to 55K,FR-A240-30K to 55K

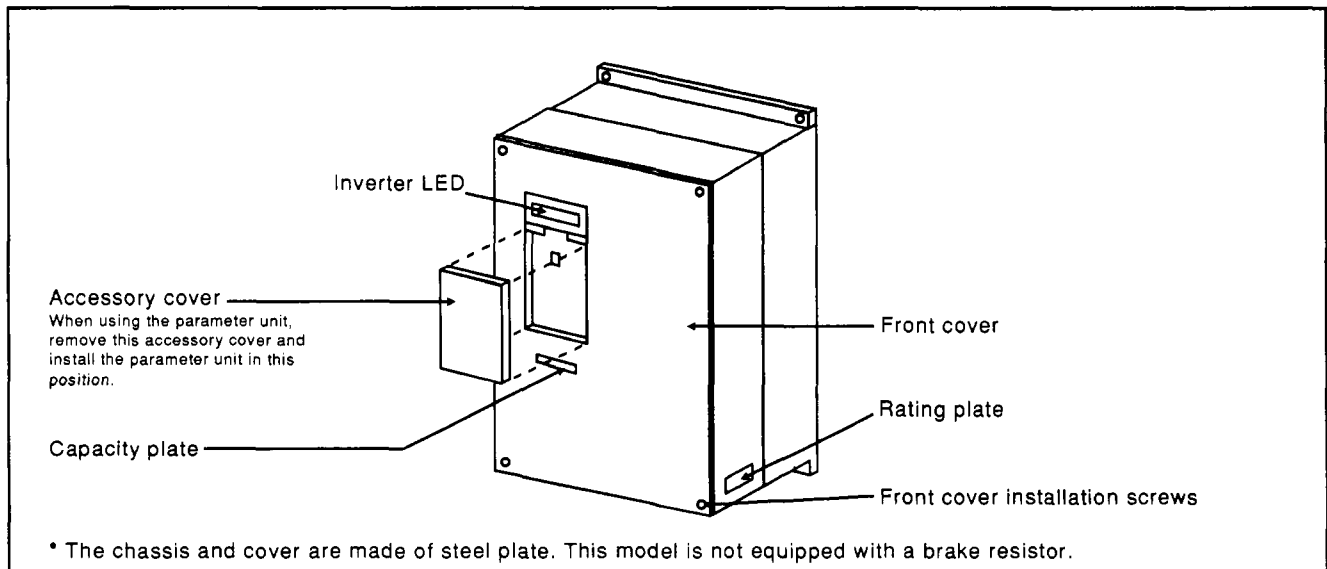

2. STRUCTURE

2.2 Removal and Reinstallation of the Front Cover

- FR-A220-0.4K(P) to 7.5K(P) • FR-A240-0.4K(P) to 7.5K(P)

To remove the front cover, hold both sides of the front cover top and pull the cover toward you. (See Fig. 2.1.)

To reinstall the front cover, fit the sockets at the cover bottom into the catches of the inverter, and securely press the cover against the inverter using the catches as supports. (See Fig. 2.2.)

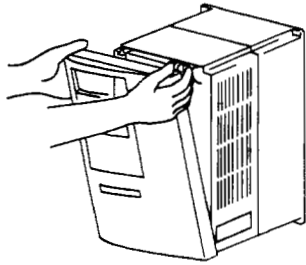

Fig. 2.1 Removing the Front Cover

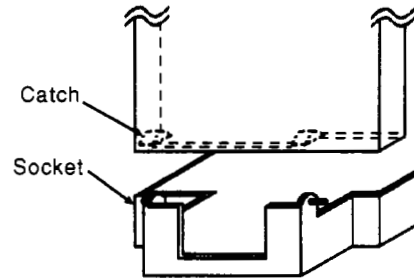

Fig. 2.2 Reinstalling the Front Cover

- FR-A220-11K to 22K • FR-A240-11K to 22K

To remove the front cover, remove the two installation screws at the front cover bottom, and hold and pull both ends of the cover bottom toward you. (See Fig. 2.3.)

To reinstall the front cover, insert the catches inside the cover top into the sockets of the inverter, press the cover against the inverter, and fix it with the bottom screws. (See Fig. 2.4.)

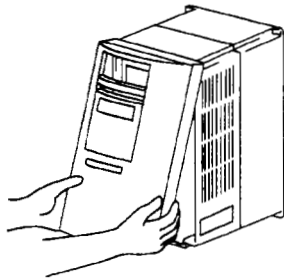

Fig. 2.3 Removing the Front Cover

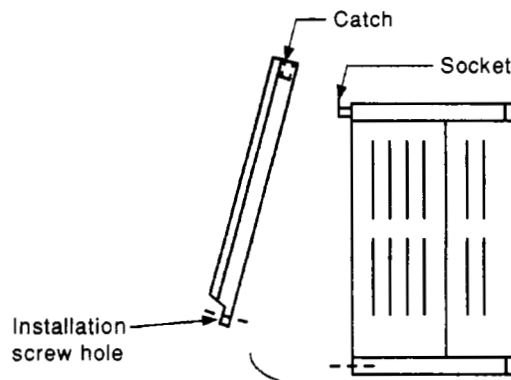

Fig. 2.4 Reinstalling the Front Cover

- FR-A220-30K to 55K • FR-A240-30K to 55K

Remove the front cover installation screws.

Note: (1) Fully check that the front cover has been reinstalled securely.

(2) The same serial number is printed on each of the capacity plate on the front cover and the rating plate on the side face. Before reinstalling the front cover, check the serial number to ensure that the cover removed is installed to the inverter from which it has been removed.

2. STRUCTURE

When the inverter surface is stained with fingermarks, oil and/or the like, gently wipe that area with a soft cloth soaked with a neutral detergent or ethanol.

Note: (1) Do not use any solvent, such as acetone, benzene and toluene, that will cause the inverter surface to dissolve and the paint to peel.

Note: (2) Do not clean the lens of the inverter LED with a detergent or alcohol which will easily affect the lens.

2.3 Removal and Reinstallation of the Parameter Unit

To remove the parameter unit, hold down the top button of the parameter unit (using the catch as a support) and pull the parameter unit toward you as shown in Fig. 2-5. To reinstall, fit the fixing hole of the parameter unit into the catch of the cover, then push it into the inverter (using the catch as a support).

Note:

- Do not install the parameter unit when the front cover does not exist on the inverter.
- When installing the parameter unit, do not apply force to the display (liquid crystal) area.

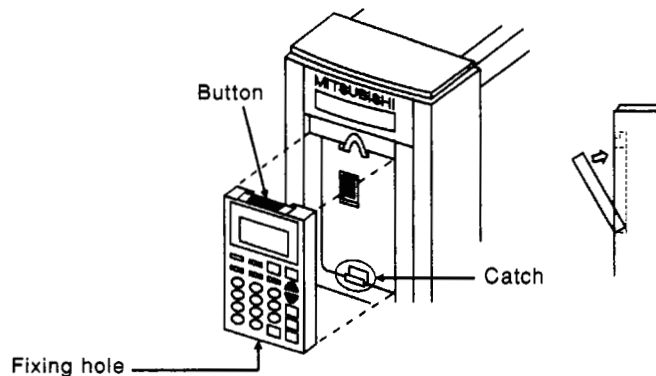

Fig. 2.5 Removing and Reinstalling the Parameter Unit

2.4 Removal and Reinstallation of the Accessory Cover

As described in the removal and reinstallation of the parameter unit, to remove the accessory cover, hold down the top and pull the accessory cover toward you. To reinstall, fit the fixing hole into the catch of the cover and push the cover into the inverter.

2. STRUCTURE

2.5 Handling of the FR-PU01E Parameter Unit

The FR-PU01E parameter unit can be used by connection to the FR-A series inverter by a cable (option).

Note: When the FR-PU01E parameter unit is used, reset (or power down) the inverter after the unit is connected. Otherwise the parameter unit will not function. The functions of the FR-A series inverter are limited with the FR-PU01E. (Read and write of the parameters Pr. 80 to 231 cannot be performed. Any attempt to set the above parameters results in Err display.) The calibration function parameter numbers 900 to 905 should be set using the third functions C1 to C6 of the FR-PU01E.

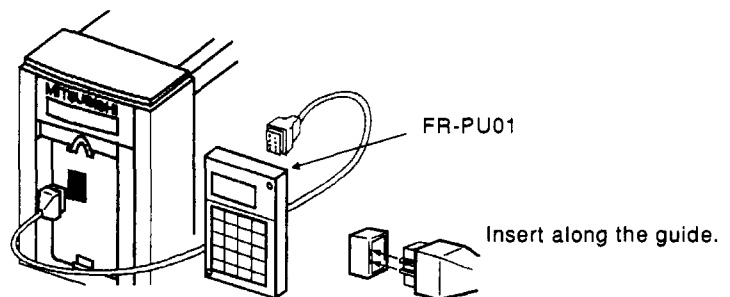

Fig. 2.6 Connection of the FR-PU01E Parameter Unit

2.6 Handling of the FR-ZRWE Parameter Copy Unit

Like the FR-PU01E, the FR-ZRWE parameter unit can be used by connection to the inverter by the cable (option), provided that the functions are limited. In addition, the function of reading and copying a batch of parameters to another inverter cannot be used.

MEMO

3. INSTALLATION

3.1 Transportation

During transportation, handle the inverter carefully to protect it from damage.

Hold the inverter so as not to apply force only to the front cover of the inverter.

3.2 Place of Installation

- (1) Do not install the inverter where it is subjected to direct sunlight, high temperature, high humidity, oil mist, flammable gases, fluff, dust, dirt, etc. Install the inverter in a clean place or inside a totally enclosed panel which does not accept any suspended matter.

Note: When the inverter is installed in a panel, determine the cooling method and panel dimensions so that the ambient temperature of the inverter is within the permissible range (as specified on page 102).

Extreme care must be taken when two or more inverters are installed and a ventilation fan is mounted in the panel. If the inverters and/or ventilation fan is installed in an improper position, the ambient temperature will rise and ventilation effect will reduce.

Like the inverter, protect the parameter unit from direct sunlight, high temperature and high humidity.

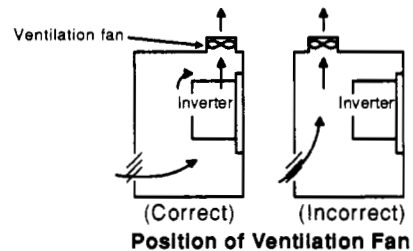
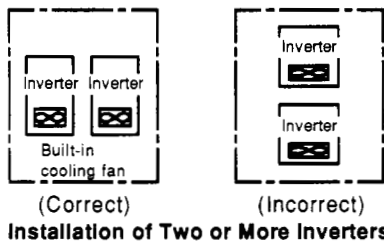

- (2) Install the inverter where it is not subjected to vibration.

3. INSTALLATION

3.3 Installation Direction and Clearances

- (1) Install the inverter on an installation surface securely and vertically (so that the letters **FREQROL-A200** are located at the front) with screws or bolts.
- (2) Leave sufficient clearances around the inverter for adequate heat dissipation.
- (3) For the inverter model of the 7.5K or down, if operation at a high duty is required, the surface temperature of the brake discharging resistor installed on the rear surface of the inverter may rise to high temperature (up to about 150°C). To prevent problems, install the inverter on an incombustible backplate (such as metal).

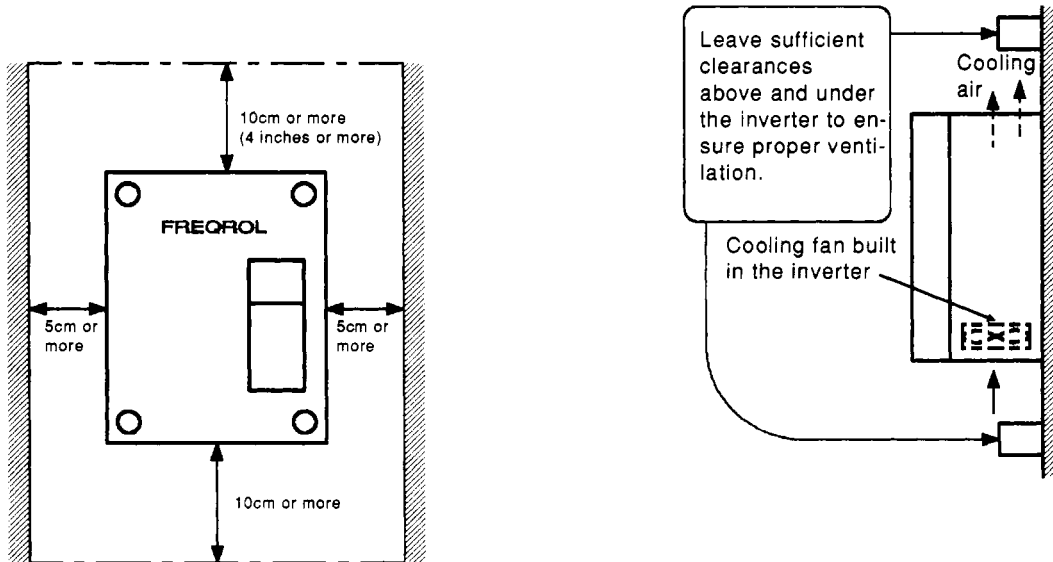
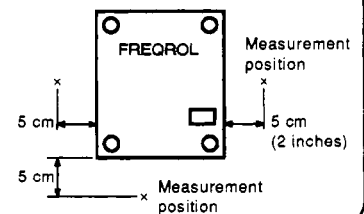

Fig. 3.2 Clearances Around the Inverter

Notes on Ambient Temperature

The ambient temperature of the place where the inverter is installed must not exceed the permissible value (50°C) because it greatly influences the life of the inverter. Check that the ambient temperature is within the permissible range in the positions shown on the right.



4. WIRING

4.1 Wiring Instructions

Note the following when wiring to prevent miswiring and misuse.

Notes on Wiring

- (1) The power must not be applied to the output terminals (U, V, W) , otherwise the inverter will be damaged.
- (2) Connect only the recommended optional brake resistor between the terminals P and PR. In addition, these terminals must not be shorted.
- (3) Use sleeved solderless terminals for the power supply and motor cables.
- (4) The common terminals SD, 5 and SE of the control circuit (isolated from each other) must not be grounded.
- (5) Use shielded or twisted cables for connection to the control circuit terminals and run them away from the main and power circuits (such as 200V relay sequence circuit).
- (6) When rewiring after operation, make sure that the inverter LED has gone off and that the charge lamp on the printed circuit board or beside the terminal block has gone off.
- (7) The cable size for connection to the control circuit terminals should be 0.75mm^2 . Run the cables so that they do not occupy much of the control box terminal block space.
- (8) Cut off the wiring cover (protective bush) windows using nippers or a cutter when running the cables.
- (9) When the power supply voltage is special (400V class), change the connection of the jumper in the internal transformer, according to the variation around 400V.

Design Information to Be Checked

- (1) The inverter will be damaged not only by miswiring but also by a sneak current from the power supply if there is a commercial power supply switch-over circuit shown on the right. To prevent this, provide electrical and mechanical interlocks for MC1 and MC2.

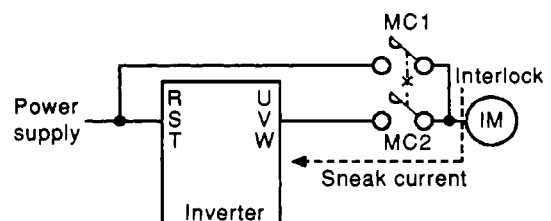

- (2) If the start signal (start switch) remains on after a power failure, the inverter will automatically restart as soon as the power is restored. When a machine restart is to be prevented at power restoration, provide a magnetic contactor MC in the primary circuit of the inverter and also make up a sequence which will not switch on the start signal.
- (3) Since input signals to the control circuit are at a low level, use two parallel micro signal contacts or a twin contact for contact inputs to prevent a contact fault.

4. WIRING

- (4) Do not apply a voltage to the contact input terminals (e.g. STF) of the control circuit.
- (5) Do not apply a voltage directly to the alarm output signal terminals (A, B, C). Apply a voltage via a relay coil, lamp, etc. to these terminals.

4. WIRING

4.2 Main Circuit Refer to page 106 and 107 for the terminal block arrangement.

(1) Connection of the power supply and motor

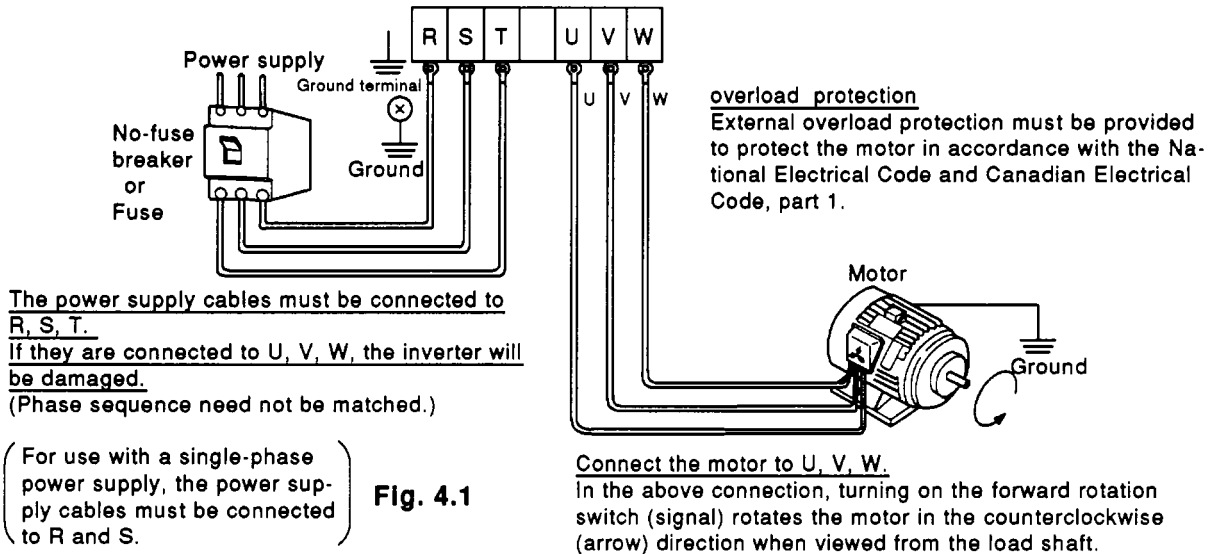

(2) Connecting the control circuit to a power supply separately from the main circuit

If the magnetic contactor (MC) in the inverter power supply is opened when the protective circuit is operated, the inverter control circuit power is lost and the alarm output signal cannot be kept on. To keep the alarm signal on, terminals R1 and S1 are available. In this case, connect the power supply terminals R1 and S1 of the control circuit to the primary side of the MC.

FR-A220-0.4K(P) to 3.7K(P)
FR-A240-0.4K(P) to 3.7K(P)

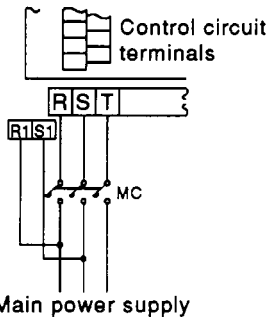

FR-A220-5.5K(P) to 55K
FR-A240-5.5K(P) to 55K

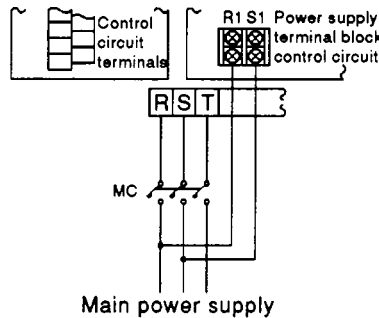

Connection procedure

- 1) Loosen the upper screw.
- 2) Remove the lower screw.
- 3) Pull out the jumper.
- *4) Connect the cable of the other power supply to the lower terminal.

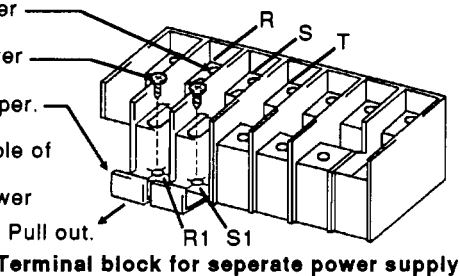

Fig. 4.2

Connection procedure

- 1) Loosen the upper screw.
- 2) Remove the lower screw.
- 3) Pull out the jumper.
- *4) Connect the cable of the other power supply to the lower terminal.

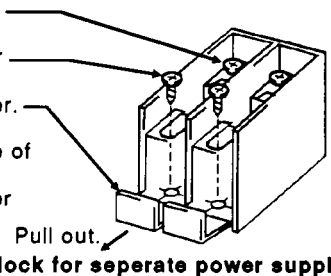

Fig. 4.3

Note*: The power supply cable must not be connected only to the upper terminal to protect the inverter from damage.

To use a separate power supply, the jumpers between R-R1 and S-S1 must be removed.

4. WIRING

(3) Connection of the dedicated brake resistor (option)

The built-in brake resistor is connected across terminals P and PR. Only when the built-in brake resistor cannot thermally accept operation at high duty, disconnect the jumper from across terminals PR-PX. In place of that resistor, connect the external dedicated brake resistor (option) across terminals P and PR. Do not connect any brake resistor other than the dedicated brake resistor. Do not connect the external brake resistor with the terminals between PR-PX shorted, otherwise inverters might be damaged.

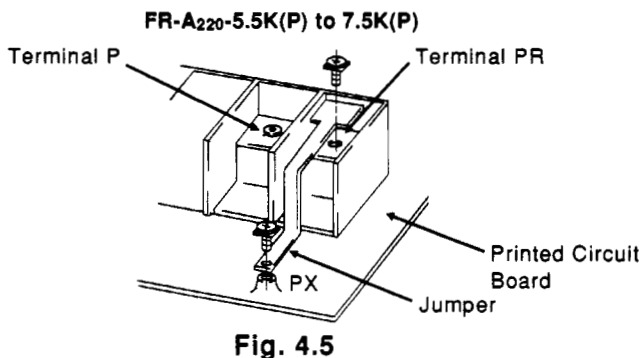
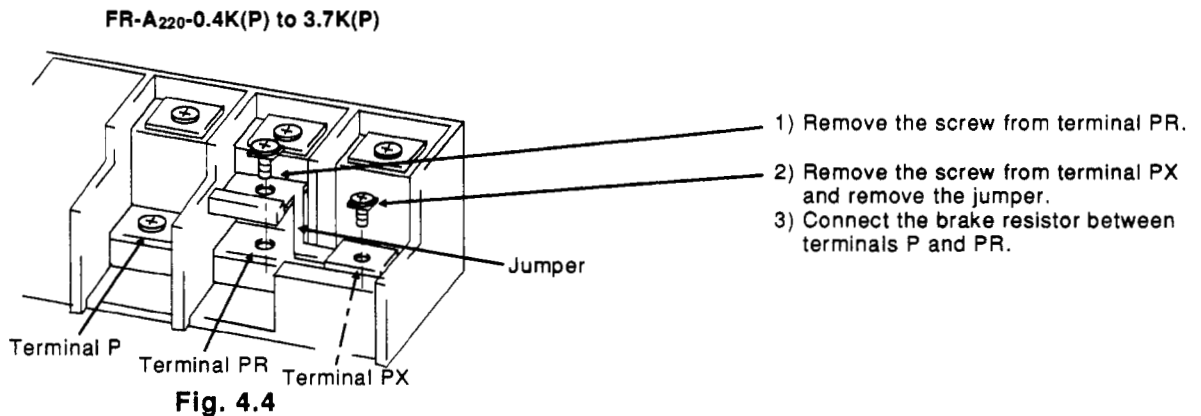

Connection procedure

- 1) Remove the screw from terminal PR.
- 2) Remove the screw from terminal PX and remove the jumper.
- 3) Connect the brake resistor between terminals P and PR.

(4) Connection of the FR-BU brake unit (option)

Connect the optional FR-BU brake unit as shown on the right to improve the braking capability during deceleration.

Connect the inverter terminals (P, N) and FR-BU brake unit terminals so that their symbols match with each other. (Incorrect connection may damage the inverter.) Also, the jumper across terminals PR-PX must be removed.

Note: The wiring distance between the inverter, brake unit and resistor unit should be within 5m (within 10m if twisted wires are used).

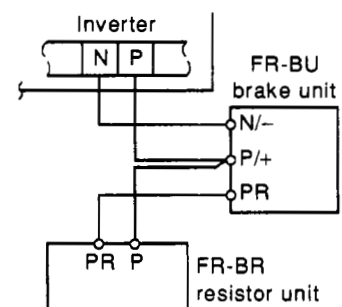

4. WIRING

(5) Connection of the power factor improving DC reactor (option) (for 5.5K to 55K inverters)

Connect the FR-BEL power factor improving DC reactor between terminals P1 and P.

In this case, the jumper connected across terminals P1-P must be removed. Otherwise, the reactor will not operate.

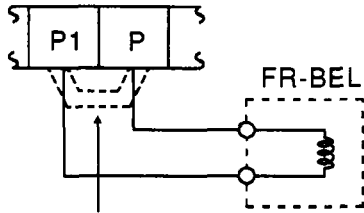

Remove the jumper.

Note: 1. The wiring distance should be within 5m.

2. The size of the cables used should be identical to or larger than that of the power supply cables (R, S, T).

3. The DC reactor cannot be used with the inverters of 3.7K and down (for both 200V and 400V).

(6) Where the power supply is special (342V or below, 484V or above) for the 400V series (11K to 55K inverters)

Change the connection of the jumper to the internal transformer according to the operating power supply voltage. (Factory set to the V2 terminals.) (But changing does not be required for 7.5K or below inverter.)

Voltage range

Jumper Connecting Position	Operating Power Supply Voltage		Note
	50Hz	60Hz	
V1	323V (380V-15%) to 456.5V (415V+10%)	As on the left	
V2	342V (380V-10%) to 484V (440V+10%)	342V (380V-10%) to 506V (460V+10%)	FACTORY SET
V3	391V (460V-15%) to 506V (460V+10%)	As on the left	

Note: Change the jumper position according to the operating power supply voltage. Otherwise the inverter will be damaged.

4. WIRING

Changing the jumper position

- FR-A240-11K to 22K

- 1) Remove the mounting screws of the terminal symbol cover and remove the cover.
- 2) This reveals the terminal block of the internal transformer. After removing the screws from the jumper in the terminal block, reconnect the jumper in accordance with the operating voltage in the above table.

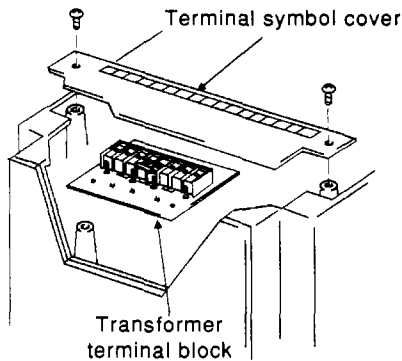

- FR-A240-30K to 55K

- 1) Remove the terminal cover of the internal transformer located under the main circuit terminal block (R, S, T).
- 2) After removing the screws from the jumper in the terminal block, reconnect the jumper in accordance with the operating voltage in the above table.

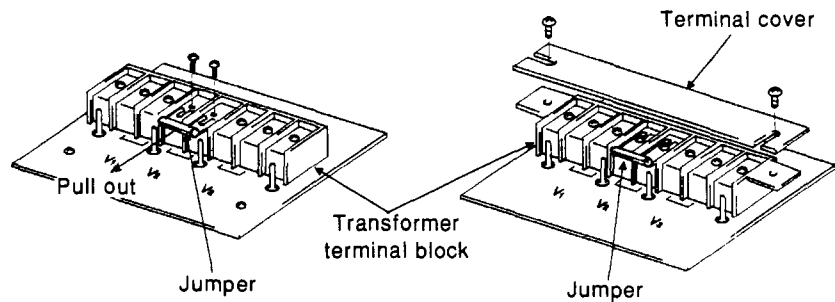

Notes on Grounding

The leakage current of the A200 series is larger than that of the Z200 series. To prevent accidental electric shock, the motor and inverter must be grounded (class 3 grounding...grounding resistance must be 100 Ω or less).

Ground the inverter by connecting it to the dedicated ground terminal.

(Do not use the screw in the case, chassis, etc.)

4. WIRING

4.3 Control Circuit Refer to page 106 for the terminal block arrangement.

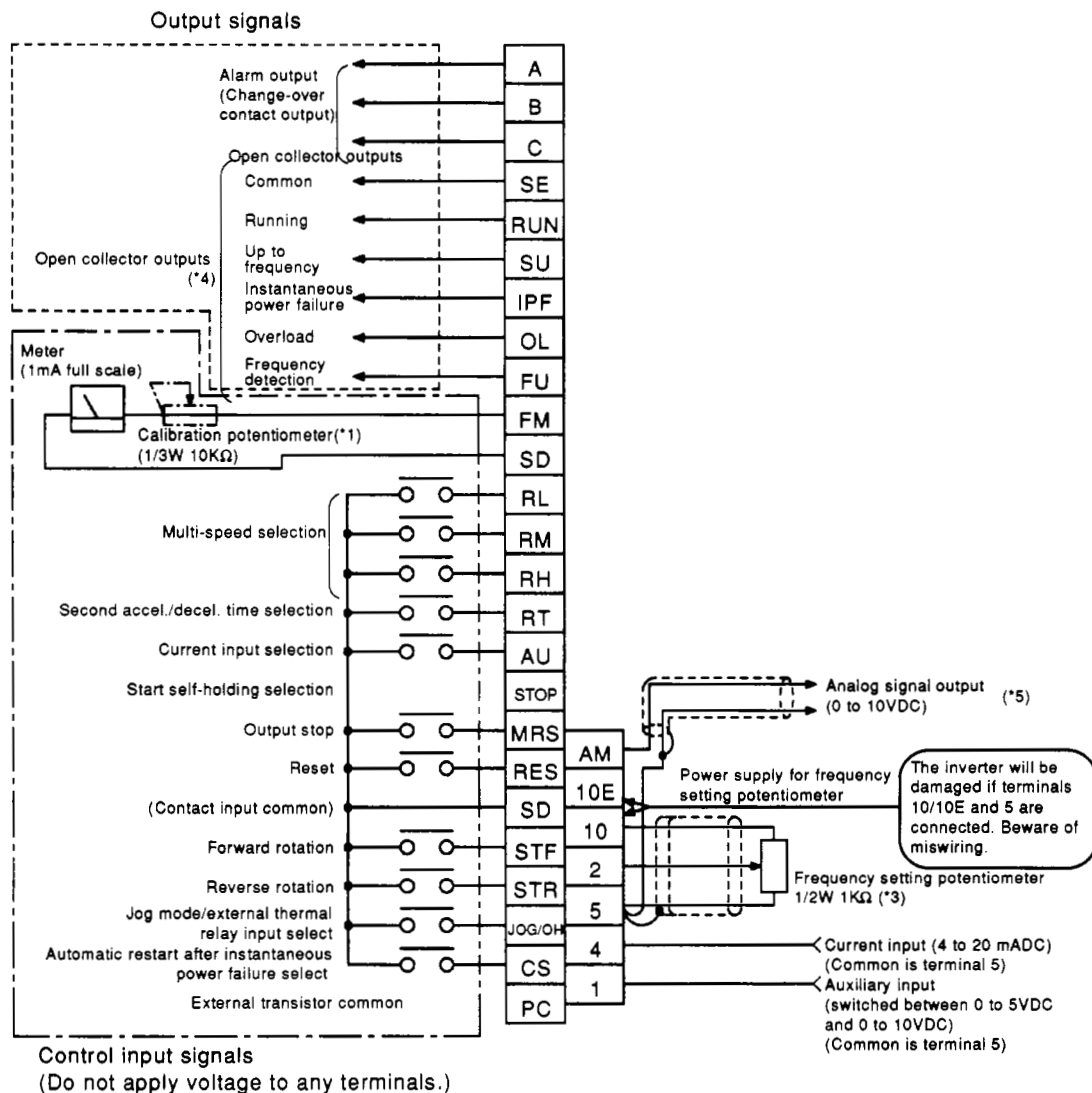

CAUTION

1. Terminals SD and 5, which are the common terminals of the I/O signals and are isolated from each other, must not be grounded.
2. Use shielded or twisted cables for connection to the control circuit terminals and run them away from the main and power circuits (including the 200V relay sequence circuit).
3. Since the frequency setting signals are micro currents, use two parallel micro signal contacts or a twin contact to prevent a contact fault.

(*1) 4. This calibration potentiometer is not required when making calibration from the parameter unit.

(*2) 5. Input signal switching can be done from the parameter unit.

(*3) 6. 2W 1K is recommended when the frequency setting is changed frequently.

(*4) 7. The output terminals other than the running (RUN) terminal allow alarm definition to be output in alarm codes and nine functions to be assigned individually.

(*5) 8. FM-SD and AM-5 functions can not be used simultaneously.

4. WIRING

- **Using the STOP terminal**

Connect as shown below to self-hold the start signal (forward rotation, reverse rotation).

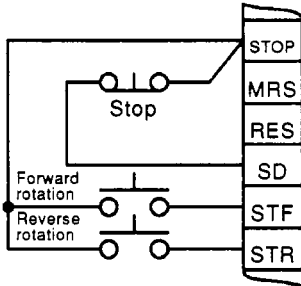

- **Using the CS terminal**

Used to perform automatic restart after instantaneous power failure and switch-over between commercial power supply and inverter.

Example: Automatic restart after instantaneous power failure

- (1) Connect CS and SD.
- (2) Set 0 in parameter 57.

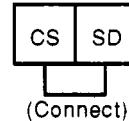

- **Using the PC terminal**

Used to connect transistor output (open collector output) such as a programmable logic controller (PC). Connecting the external power supply common for transistor output to the PC terminal prevents a faulty operation caused by a sneak current.

Note: AY40 requires DC24V power supply

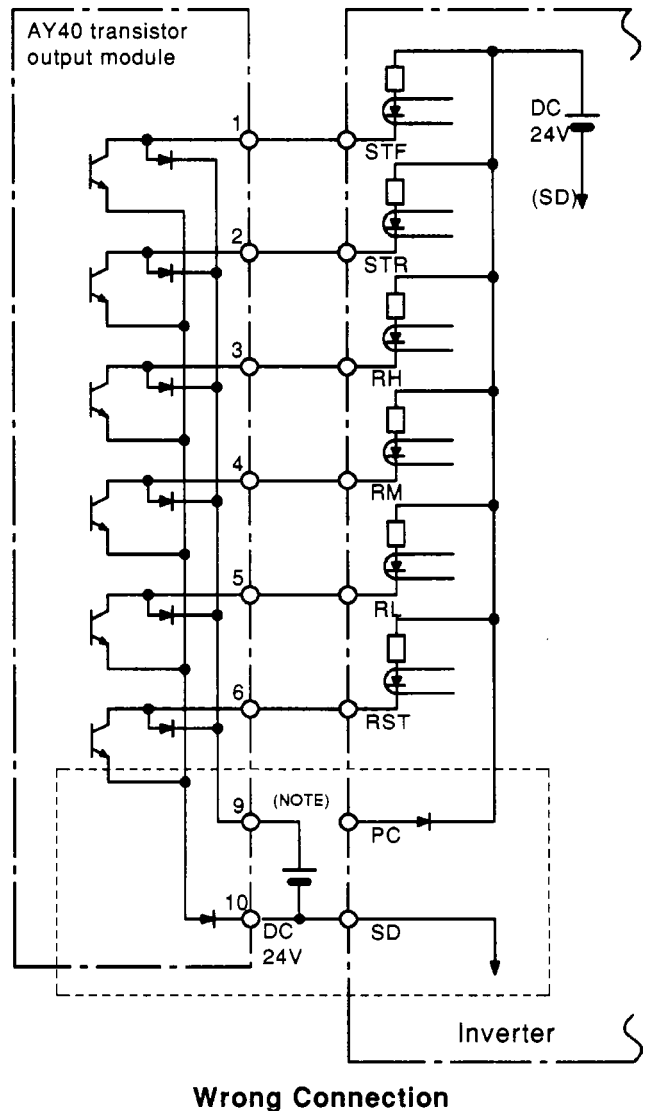
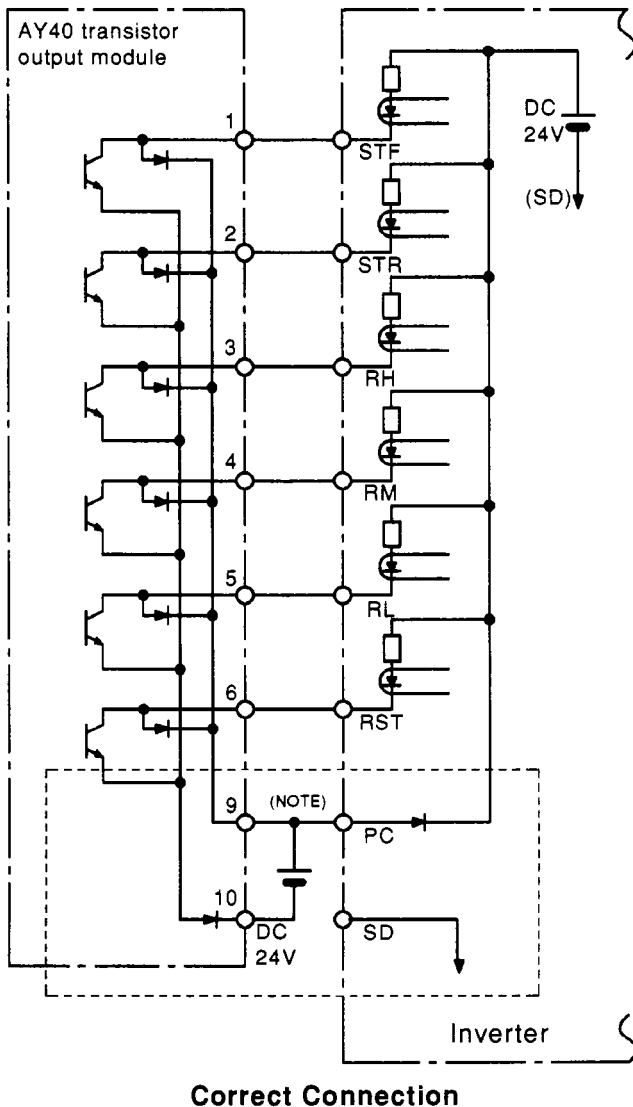

5. OPERATION

5.1 Operation Mode

Select any of the following operation modes according to the application and operating specifications:

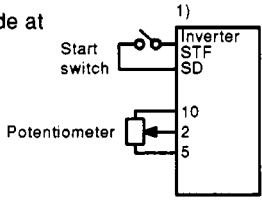
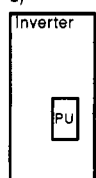
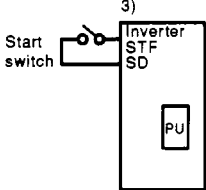
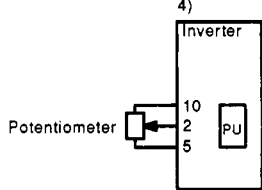
Operation Mode	Description	Remarks
Operation using the external input signals	The inverter is operated with the start switch, frequency setting potentiometer, etc. connected to the control terminals of the inverter.	Factory-set to select this operation mode at power on.* 
Operation using the parameter unit	The inverter is started, set in frequency, and operated at variable speed from the parameter unit.	Prepare the parameter unit if it is not provided for the inverter. (See page 22 for the operating procedure.) 
Combined operation using the external input signals and parameter unit	Start is made by the external input signal, and the running frequency is set from the parameter unit.	The external frequency setting potentiometer and the forward rotation, reverse rotation and stop keys of the parameter unit are invalid. 
	The running frequency is set by the external input signal, and start and stop are effected from the parameter unit.	The external input signal start switch is invalid. 

*Parameter unit operation mode may be selected at power on. (See page 27.)

5.2 Pre-Operation Checks

After the installation and wiring procedures are complete, make the following checks before starting operation:

- (1) Check that the wiring is correct. Especially check that the power supply is not connected to terminals U, V and W.
- (2) Check that there are no faults such as short circuit due to wire off-cuts, etc.
- (3) Check that the screws, terminals, etc. are securely tightened.
- (4) Check that the motor and inverter are grounded.

Insulation resistance test using megger

- Perform the insulation resistance test using a megger in accordance with the procedure on page 80.
- Do not conduct the insulation resistance test on the inverter terminals and control circuit terminals.

5. OPERATION

5.3 Pre-Operation Settings

The inverter is not provided with setting switches, potentiometers, or links for control purposes.

Use the parameter unit (FR-PU02E) to change or check the set values of various functions (e.g. acceleration/deceleration time, electronic overcurrent protector) according to the load and operational specifications. (See page 52 for the factory-set values of the functions.)

For the set value changing and checking procedures, see the section of the "PARAMETER UNIT" in this manual (from page 22 onward).

The main items to be set before operation are as follows:

Item	Description	Ref. Page
Maximum output frequency	<ul style="list-style-type: none"> • External input signal operation mode The maximum output frequency is factory-set as indicated below. The setting must be changed when the inverter is run at a higher value. <Maximum output frequency value set at the factory> <ul style="list-style-type: none"> • Voltage signal...5VDC (or 10VDC) for 60Hz • Current signal...20mADC for 60Hz, 4mADC for 0Hz <Changing the maximum output frequency setting> Change the values of "frequency setting voltage bias and frequency setting voltage gain" (or "frequency setting current bias and frequency setting current gain") from the parameter unit. (Pr. 902 to 905) • Parameter unit operation mode The maximum output frequency is up to the maximum frequency (factory-set to 120Hz). 	p.68
Acceleration/deceleration time	<p>Factory-set to 5 seconds for the 7.5K or down, and 15 seconds for the 11K or up. Set the required value if the inverter is operated at other than the above value.</p> <p>The set time is the length of time until when the set value in "acceleration/deceleration reference frequency Pr. 20" is reached.</p>	p.57
Electronic overcurrent protector	<p>The set value is identical to the protection level value of the conventional inverters (FR-Z120, Z200, Z300). Set the value of current for 50Hz indicated on the motor rating plate.</p> <p>Note: The operational characteristics are based on the Mitsubishi standard squirrel-cage motor. Since the electronic overcurrent protector cannot be applied to a special motor, protect a special motor using an external thermal relay or the like. (For a constant-torque motor, this function can be set in the parameter.)</p>	p.57

5. OPERATION

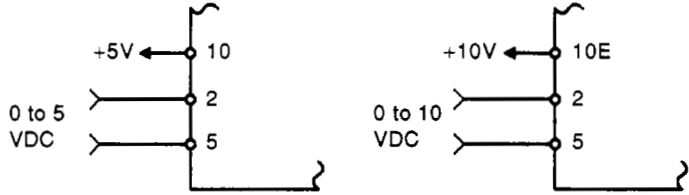
Item	Description	Ref. Page
<p>Frequency setting input signal setting (for operation with analog signal)</p>	<p>Set the specifications of the frequency setting voltage signal entered across terminals 2-5. (The A200 inverter does not contain the switching connector unlike the Z200 and Z300 series inverters.)</p> <ul style="list-style-type: none"> • Operation at 0 to 5VDC Set 1 in function number 73. • Operation at 0 to 10VDC Set 0 in function number 73. • Operation at 4 to 20mADC <u>4 to 20mADC input is only selected when terminals AU-SD are connected.</u> Hence, AU and SD must be connected to perform operation with this signal. 	<p>p.68</p>
<p>Maximum frequency Minimum frequency</p>	<p><u>To be only used to restrict the upper and lower limits of the output frequency.</u> Though setting may be made at less than the maximum output frequency, proper operation cannot be performed if it is set to an unreasonable value.</p> <p>Note: Setting the minimum frequency causes the motor to operate at the set minimum frequency by merely switching on the start signal.</p>	<p>p.56</p>
<p>Meter calibration</p>	<p>Allows the meter to be calibrated from the parameter unit without using the calibration resistor.</p>	<p>p.48</p>

5. OPERATION

5.4 Check Points during Test Run

After checking that the inverter start signal is off (in the external signal operation mode), switch on the no-fuse breaker (NFB) and magnetic contactor (MC) in the inverter input circuit.

Perform a test run and check the operating status in the following procedure:

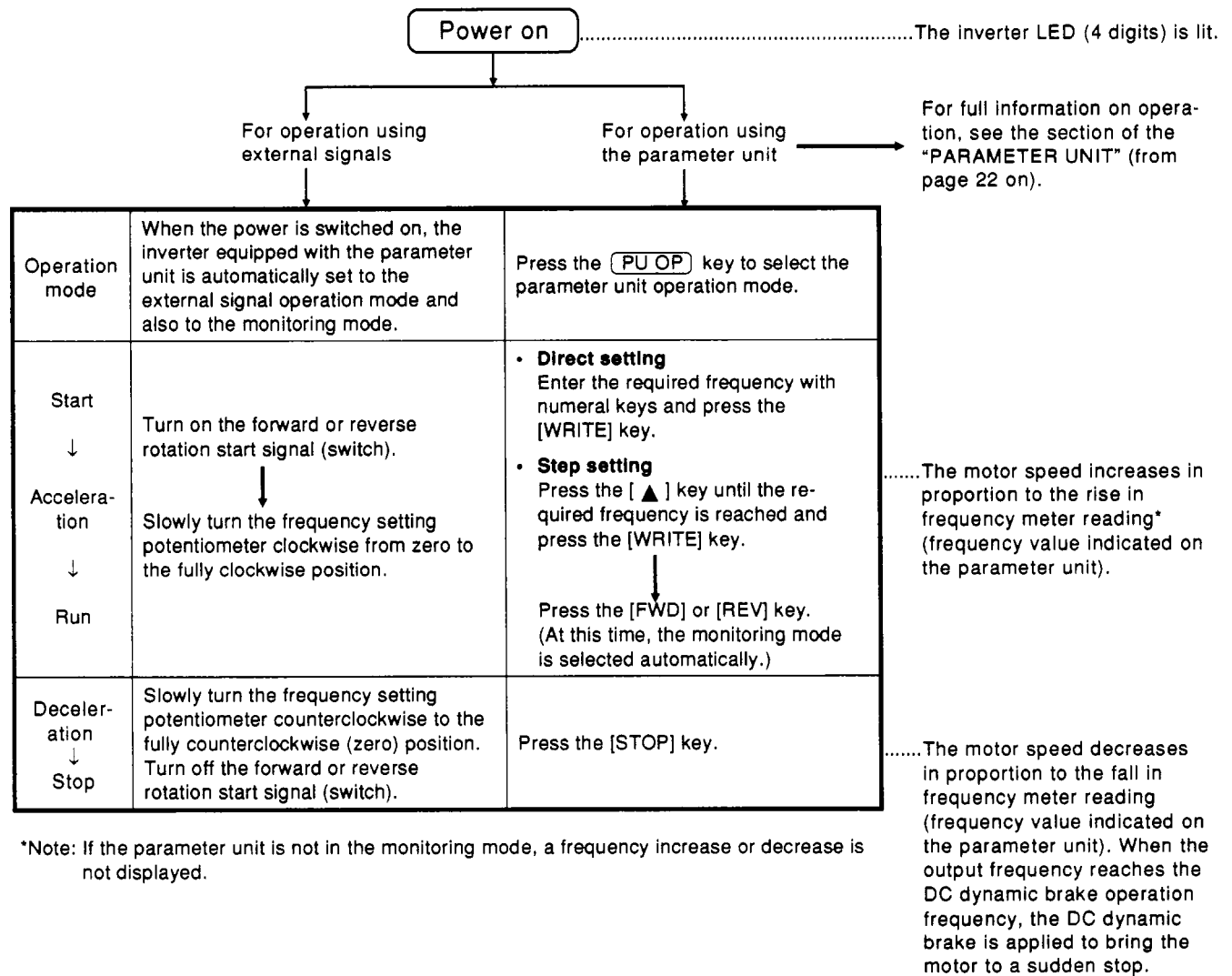

5. OPERATION

Check Points

- (1) Check that the direction of motor rotation is correct. (See page 11 for the wiring and rotation direction.)
- (2) Check that the motor is free from unusual noise or vibration.
- (3) Check that the frequency meter deflects smoothly.
- (4) Check that the "OL" code is not displayed on the parameter unit during acceleration or deceleration. If the "OL" code is displayed:
 - Check that the load is not too large.
 - Increase the acceleration/deceleration time.
 - Reduce the boost value.

Note

- (1) The inverter is not started up if the forward rotation (STF) and reverse rotation (STR) start signals are turned on at the same time.
The motor is decelerated to a stop if the above signals are switched on at the same time during operation.
- (2) When ALARM is displayed on the inverter LED and the motor is coasted to a stop, make sure that the motor has stopped, then reset the inverter by switching the power off or using the reset terminal.

6. PARAMETER UNIT

6.1 Structure of the Parameter Unit

The FR-PU02E parameter unit is installed to the FR-A series inverter or connected to it by a cable (option) and allows operation to be performed, functions to be selected (set values to be read/written), the operating status to be monitored, and alarm definition to be displayed. In addition, the FR-PU02E has a troubleshooting function, help function and parameter graphic display function.

The FR-PU02E parameter unit is hereinafter referred to as the PU.

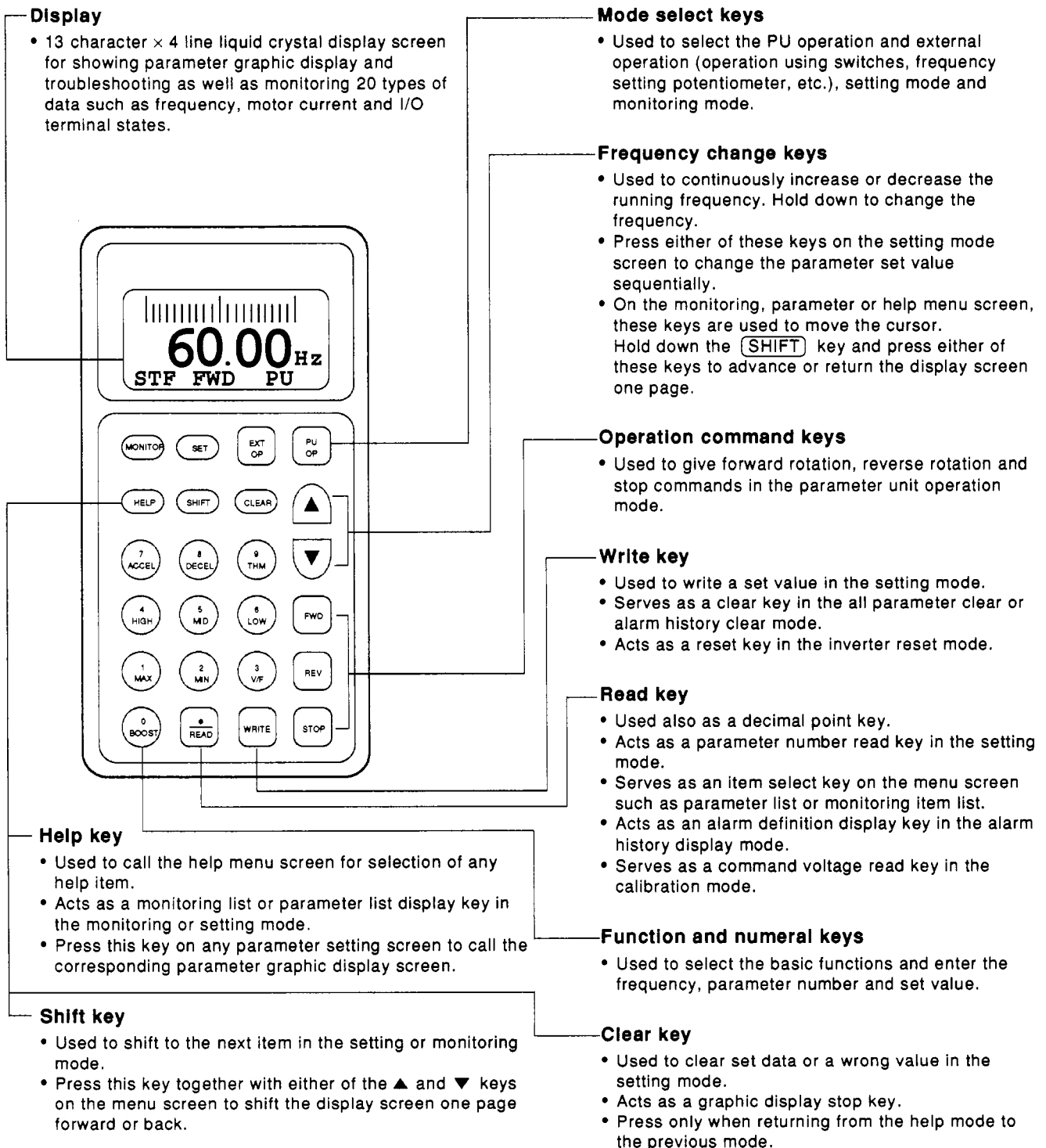

6. PARAMETER UNIT

6.2 Installation of the Parameter Unit

The PU may either be installed directly to the inverter or connected to the inverter by the optional cable so that it may be hand-held or installed to a panel. The PU may be installed and removed when the inverter is powered up or running.

(1) Direct Installation to the Inverter

The PU is used on the front cover of the inverter (electrically coupled by the connector). For the model not equipped with the PU, remove the accessory cover from the inverter front cover and install the PU to that position.

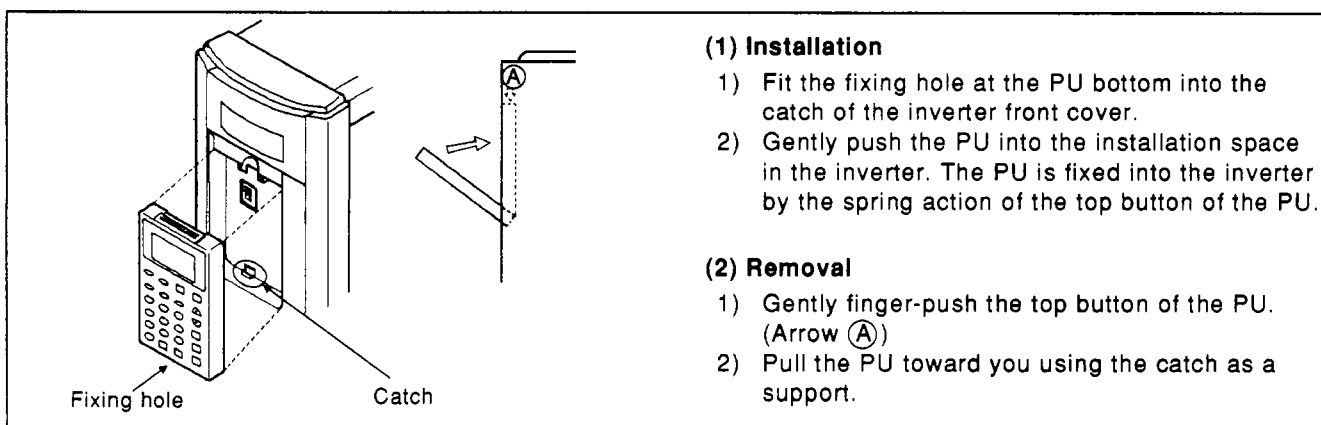

[CAUTION] The PU should only be installed on the inverter when the inverter cover is installed.

(2) Connection Using the Cable

The PU may be installed not only to the inverter but also on the surface of a panel or may be hand-held for adjustment, maintenance, inspection, etc. In this case, the dedicated cable (option) is required for connection of the PU and inverter.

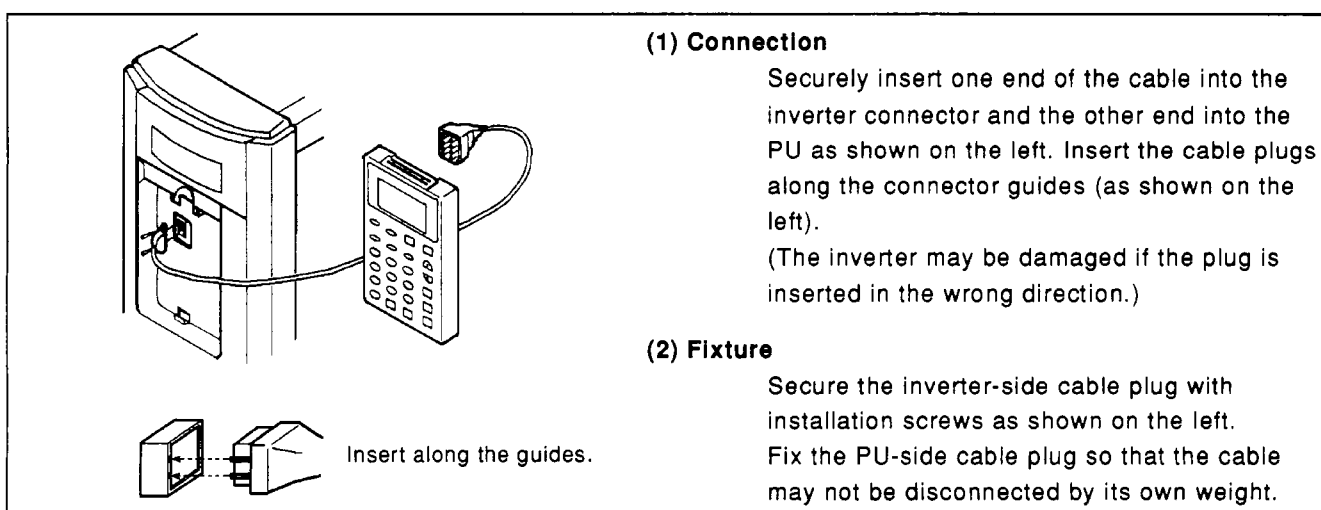

[CAUTION] The dedicated PU cable (option) may only be used to connect between the PU and inverter.

6. PARAMETER UNIT

(3) Handling of the FR-ARWE parameter copy unit

Like the FR-PU02E, the FR-ARWE fitted to the inverter (can also be connected by the cable) allows operation and functions to be set and operation status to be monitored. (The [▲] and [▼] keys are different in function from those of the FR-PU02E.)

The FR-ARWE also allows the inverter parameters set per application to be read in batches and easily copied to the other inverter.

(4) Use of the FR-PU01E Parameter Unit

Like the FR-PU02E, the FR-PU01E can be used by connection to the inverter by the cable (option). It is to be understood that the FR-PU01E cannot be fitted directly to the inverter.

Note the following:

- 1) When the power is on, the FR-PU01E parameter unit and FR-PU02E parameter unit cannot be exchanged with each other. Before using the FR-PU01E parameter unit, reset (or switch off) the inverter once with the FR-PU01E and inverter connected by the cable.

The inverter recognizes the parameter unit type at the time of reset cancel or power-on and does not communicate with any parameter unit other than the one recognized.

- 2) The functions of the FR-A series inverter are limited. See the following function comparison list:

No.	Function	FR-PU02 Specifications	FR-PU01 Specifications
1	Operation setting function	Frequency setting (0 to 400Hz) Forward rotation, reverse rotation, stop	As on the left.
2	Operation mode designation	PU operation, external operation Jog operation Combined PU/external operation	As on the left.
3	Monitoring function	Output frequency, output current, output voltage, alarm display, frequency set value, running speed, motor torque, converter output voltage, regenerative brake duty, electronic overcurrent protector load factor, output current peak value, converter output voltage peak value, input power, output power, input terminal state, output terminal state, load meter, motor exciting current, position pulse, cumulative operation time	Output frequency, output current, output voltage and alarm display can only be monitored.
4	Parameter setting function	All of Pr. 0 to Pr. 159 and Pr. 200 to Pr. 231 can be set.	Pr. 0 to Pr. 79 can only be set. Note that the gear backlash compensation and 5-point flexible V/F characteristic parameters cannot be set, either.
5	Calibration function	Pr. 900 to Pr. 905	C-1 to C-5 Note that C-1 cannot be used when any of 101 to 121 (AM terminal) has been set in Pr. 54.
6	Alarm display clear	Batch clear is performed using "ALARM HISTORY CLEAR" in the help mode.	Batch clear is performed by pressing the CLEAR key when error is displayed on the monitor.
7	Parameter clear (Returning the parameters to the factory setting)	Parameter clear (calibration functions not included) or all parameter clear (calibration functions included) can be set.	Only parameter clear (calibration functions not included) can be set.
8	Alarm display	OV1 to OV3 PUE, RET, CPU	OVT (Alarms indicated on the left are displayed in this way.) PE

In addition, the following functions are not available for the FR-PU01:

- Parameter initial value list
- Parameter change list
- Troubleshoot
- Inverter reset (Operation from the parameter unit)

6. PARAMETER UNIT

(5) Use of the FR-ZRWE Parameter Copy Unit

The function of reading and copying parameters cannot be used. If the unit is operated incorrectly, the parameters of the inverter to which the parameters have been copied may be corrupted and normal operation not performed.

The other functions can be used as in the FR-PU01E.

6. PARAMETER UNIT

6.3 Functions of the Parameter Unit

The PU may be used in a wide variety of applications ranging from motor operation to monitoring as described below:

Note: A parameter will be referred to as Pr.

<p>Selecting the operation mode</p>	<p>External operation and/or PU operation mode can be selected.</p> <p>External operation.....The inverter is operated using the start switch and frequency setting potentiometer connected to the inverter terminal block.</p> <p>PU operation.....The inverter is started/stopped and running frequency is set from the PU keys.</p> <p>PU/external combined operation.....The inverter is operated using the PU and external switch and potentiometer.</p> <p>The combined operation may be performed in either of the following methods:</p> <p>1)The PU keys are used for start and stop, and the external potentiometer is used for frequency setting.</p> <p>2)The external switches are used for start and stop, and the PU keys used for frequency setting.</p>
<p>Operating the motor</p>	<p>The frequency may either be entered directly from the ten-key pad or by holding down the [▲] (or [▼]) key.</p>
<p>Changing the function set value</p>	<p>The required function can be read directly or rewritten.....p. 36</p> <p>Convenient functions</p> <ul style="list-style-type: none"> • All set value clear (initialization) p. 42 • Rewrite disable..... p. 69 • Frequency meter calibration..... p. 48 • Reset selection..... p. 68
<p>Monitoring</p>	<p>The operating status (e.g. output frequency, motor current, input power) can be checked, and I/O terminal states and up to eight past alarm definitions can be monitored. The inverter is monitored by either the inverter LED display, PU main display or PU level display.</p>

6. PARAMETER UNIT

Operation Mode

The inverter has three operation modes; operation by external input signals, operation by PU and PU/external input signal combined operation. The operation mode can be selected (switched) between the external input signal operation mode and PU operation mode by the mode select keys of the PU. The other modes are selected by setting in Pr. 79. Pr. 79 also allows the operation mode to be limited (fixed). The PU operation mode may be output as a signal (see Pr. 40).

Factory-Set Operation Mode

When the input power is switched on (or reset is made), the operation mode is set to the external input signal operation mode. Hence, powering the inverter up makes it ready to operate with external input signals. In this state, turn on the start signal (across STF/STR-SD) to start operation.

Limiting (Fixing) the Operation Mode

The operation mode at power on may be limited, e.g. operation from the PU is enabled at power on without switching the operation mode with the PU's mode select key. For full information on setting the operation mode, see page 69.

Selecting the Operation Mode in the Factory-Set State (Pr. 79 setting is 0)

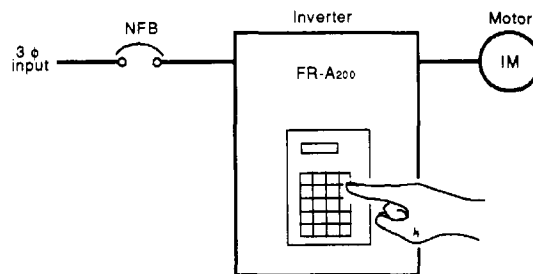
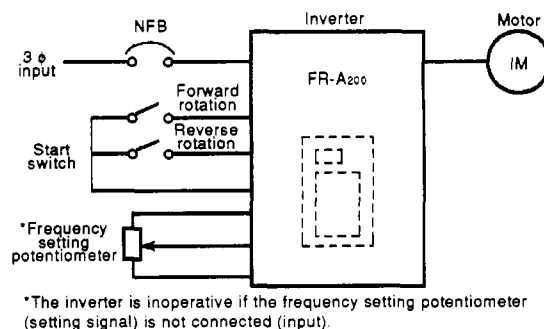
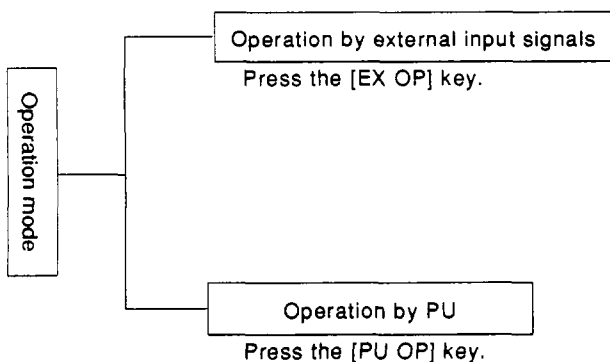

[CAUTION] Switching between the PU operation and external signal operation must be performed after the forward (or reverse) rotation signal of the PU or external input signal has *been* turned off. This switching cannot be performed if this signal is on.

Running the Motor from the Parameter Unit

6.4 Operation

The motor can be started and stopped from the PU without using the external frequency setting potentiometer or start switch.

The PU also allows jog operation.

Operating Procedure

(1) Directly entering (setting) the required frequency (Direct setting)

[PU OP] [Required frequency value] [WRITE] [FWD] (or [REV]) [STOP]

Setting the running frequency Repeating this procedure during operation allows the speed to be varied.

Setting example To run the motor in the forward direction at 30Hz.

Note: The parameters, etc. are as factory-set.

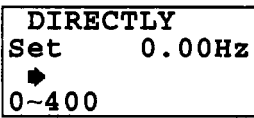
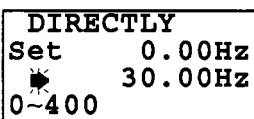
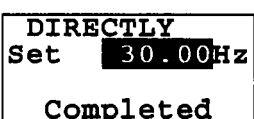
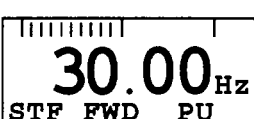
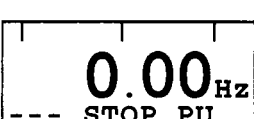
Operation and Keying Procedure	PU Screen Display	Remarks
Power on		(1)
[PU OP]		Displays the latest (previous) set value. (0Hz in the factory set state)
③ ①		(3)
[WRITE]		(4)
[FWD]		The motor starts. (900r/min for the 4-pole motor)
[STOP]		The motor stops.



Running the Motor from the Parameter Unit

(2) Directly entering (setting) the required frequency (Direct setting)

[PU OP] [Required frequency value] [WRITE] [FWD] (or [REV]) [STOP]

Setting the running frequency..... Repeating this procedure during operation allows the speed to be varied.

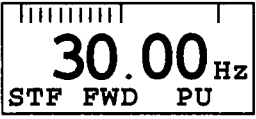
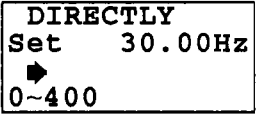
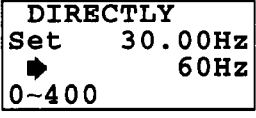
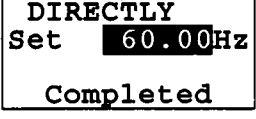
Setting example After running the motor at 30Hz again as set on the preceding page, change the set value to 60Hz.

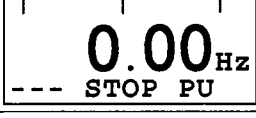
Operation and Keying Procedure	PU Screen Display	Remarks
	 <p>(7)</p>	
[FWD]	 <p>(8)</p>	The motor runs at the preceding set value.
[PU OP]	 <p>(9)</p>	
⑥ ①	 <p>(10)</p>	
[WRITE]	 <p>(11)</p>	
[FWD]	 <p>(12)</p>	The motor speed changes. (1800r/min for the 4-pole motor)
[STOP]	 <p>(13)</p>	The motor stops.

Running the Motor from the Parameter Unit

(3) Setting the required frequency by continuous speed change using the [▲] or [▼] key (Step setting)

[PU OP] [▲] (or [▼]) [WRITE] [FWD] (or [REV]) [STOP]

Setting example Change the preceding setting (60Hz) to 40Hz and run the motor in the forward direction.

Operation and Keying Procedure	PU Screen Display	Remarks
[PU OP]	<p>(14)</p>	The previous set value is displayed.
[▼] <small>Note 1:</small>	<p>(15)</p>	This value changes (reduces) continuously while the [▼] key is pressed.
	<p>(16)</p>	
[FWD]	<p>(17)</p>	The motor starts. (1200r/min for the 4-pole motor)
[STOP]	<p>(18)</p>	The motor stops.
[WRITE] <small>Note 2:</small>	<p>(19)</p>	The set value is stored into the inverter memory. (Valid any time after the [▲] or [▼] key is pressed.)

Note 1: Holding down the [▲] or [▼] key gradually increases the rate of change of the set frequency. Set to the target value by pressing and releasing the key as required.

Note 2: When the frequency has been set to the required value, the [WRITE] key must be pressed to store the set frequency. (When the power is switched off or when the PU operation mode is switched to the external operation mode and then switched back, the frequency returns to the set value as it had been before the change (60Hz in this example).)

Running the Motor from the Parameter Unit

(4) Jog operation

[PU OP] [SHIFT] [FWD] (or [REV])

Hold down the [FWD] (or [REV]) key to operate, and release to stop.

The jog operation frequency is the value set in the parameter (Pr. 15).

Operation example

1) Perform jog operation in the forward direction at 5Hz.

(5Hz is the factory-set value in Pr. 15)

2) Change the jog operation frequency to 7Hz and perform jog operation.

Operation and Keying Procedure	PU Screen Display	Remarks
[PU OP]		The previous set value is displayed.
[SHIFT]		Factory-set value
[FWD]		The motor starts. (150r/min for the 4-pole motor)
– (release the key)		Monitoring screen display in the jog operation mode.
[PU OP] [SHIFT]		
⑦ [WRITE]		The jog operation frequency is set to 7Hz.
[FWD]		The motor starts. (210r/min for the 4-pole motor)
– (release the key)		
[PU OP]		Returns to the normal PU operation mode.

Changing the Monitor Screen

The inverter can be monitored by either the LED (red light emitting diode) display on the inverter, the 5-digit liquid crystal display on the PU (PU main monitor) or the PU level meter. These displays are selected by the following method:

1. Inverter LED display

Setting Pr. 51 on the PU allows selection from 16 types of data.

For full information on the setting method, see the explanation of Pr. 51.

Pr. 51 is factory-set to the output frequency display (Pr. 51 = 1).

2. PU level meter

Setting Pr. 53 on the PU allows selection from 15 types of data.

For full information on the setting method, see the explanation of Pr. 53.

Pr. 53 is factory-set to the output frequency display (Pr. 53 = 1).

3. PU main monitor

- 5 types of data can be selected in sequence by the SHIFT key as shown below.
- Among the five monitor screens, the fifth monitor screen (selective monitoring) allows selection from 12 types of data such as the frequency set value and running speed.
- Additionally, Pr. 52 allows selection from four types of data such as the load meter and cumulative operation time.
- For full information on the select items, see the explanation of Pr. 52.

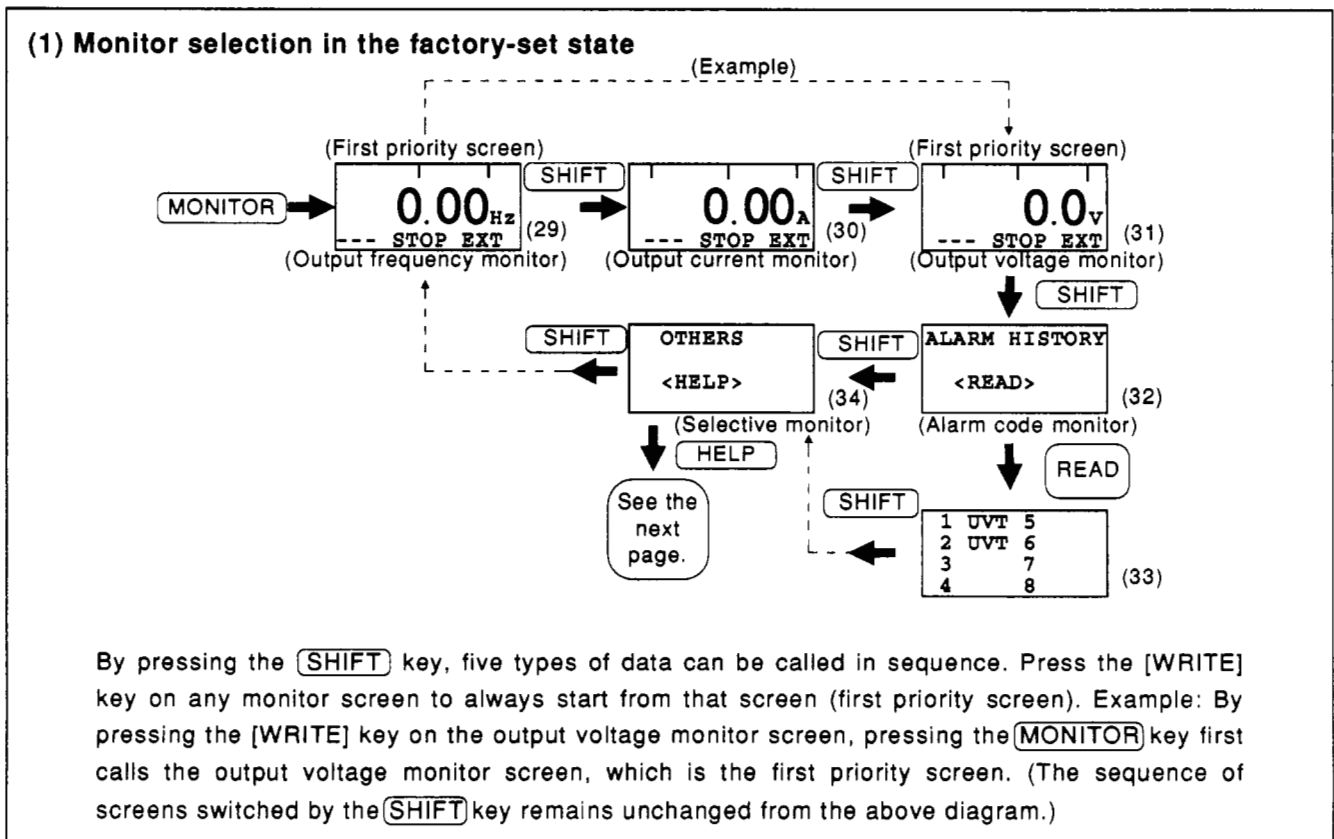

Changing the Monitor Screen

(2) Selecting a new monitor item in the selective monitoring mode

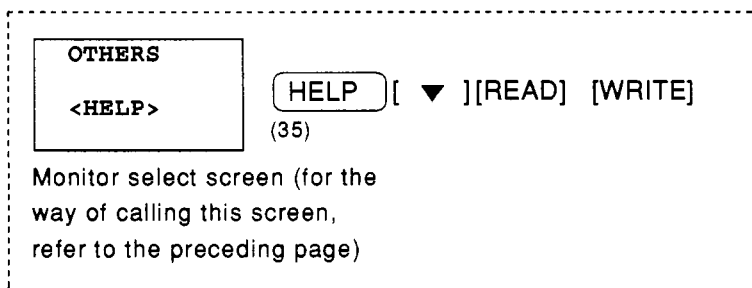

- For the items selectable, see page 64.

Setting example Select the input terminal state screen in the selective monitoring mode.

Operation and Keying Procedure	PU Screen Display	Remarks
[PU OP]	<div style="border: 1px solid black; padding: 5px;"> <p>DIRECTLY Set 60.00Hz ▼ 0~400</p> </div>	(36) The following operation can also be carried out in the external operation mode.
MONITOR	<div style="border: 1px solid black; padding: 5px;"> <p>0.00 Hz --- STOP PU</p> </div>	(37)
SHIFT SHIFT SHIFT SHIFT	<div style="border: 1px solid black; padding: 5px;"> <p>OTHERS <HELP></p> </div>	(38)
HELP	<div style="border: 1px solid black; padding: 5px;"> <p>1 Frequency 2 Current 3 Voltage 4 Alarm His</p> </div>	(39)
Hold down SHIFT [▼][▼][▼] Without pressing SHIFT Key [▼][▼]	<div style="border: 1px solid black; padding: 5px;"> <p>5 F Command 6 RPM 7 Shaft Trq 8 DC Link</p> </div>	(40) Hold down SHIFT and press [▼] or [▲] to advance or return the screen one page.
[READ] [WRITE]	<div style="border: 1px solid black; padding: 5px;"> <p>9 Br. Duty % 10 Therm O/L 11 Peak I 12 DC Peak V</p> </div>	(41)
	<div style="border: 1px solid black; padding: 5px;"> <p><input type="checkbox"/>STF <input type="checkbox"/>RL <input type="checkbox"/>MRS <input type="checkbox"/>STR <input type="checkbox"/>RM <input type="checkbox"/>STO <input type="checkbox"/>AU <input type="checkbox"/>RH <input type="checkbox"/>RES <input type="checkbox"/>RT <input type="checkbox"/>J/O</p> </div>	(42) By pressing the SHIFT key, the other monitor screens can be called.

Note 1: In this state, the I/O terminal states selected here are first displayed with priority when the other operation mode is switched to the monitoring mode. (Refer to the preceding page.) When first priority has been given to other data, press the [WRITE] key with that monitor screen being displayed. The first priority screen then switches to that monitor screen.

Note 2: When the selective monitor screen is not the first priority screen as in the above operation, the selected data is erased from the memory as soon as the power is shut off or the other operation mode (such as external operation) is selected. In this case, the selective monitoring mode must be selected again by the above procedure. When the selective monitor screen remains as the first priority screen, the selected data remains intact in the memory.

Changing the Monitor Screen

(3) Selecting any of the monitoring items "load meter", "motor exciting current", "position pulse", and "cumulative operation time"

When the "load meter" or "motor exciting current" has been selected, the output current monitor screen is switched to a corresponding screen.

When the "position pulse" or "cumulative operation time" has been selected, the output voltage monitor screen is switched to a corresponding screen. When any of these four items has been selected, therefore, the output current or output voltage monitor screen cannot be used.

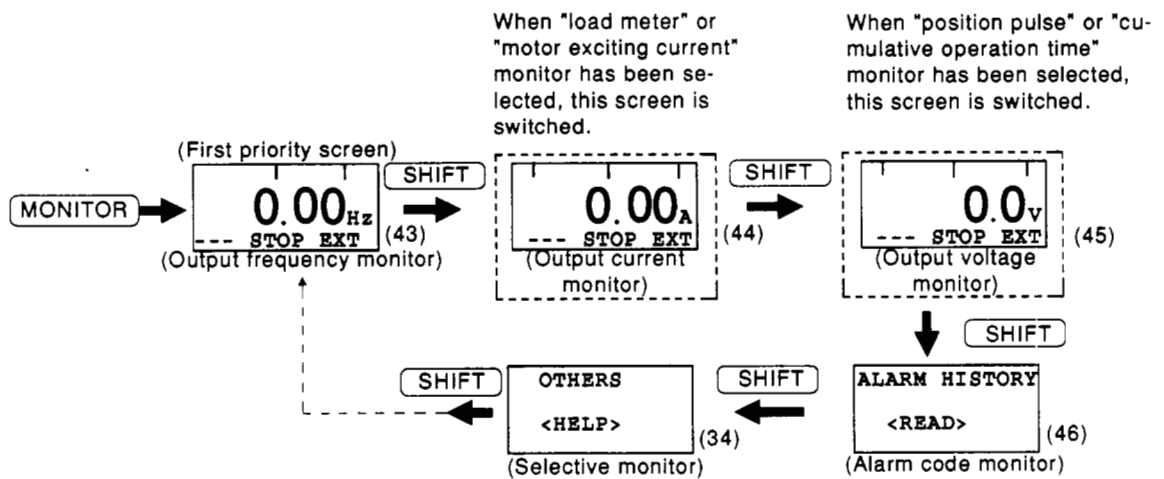

Changing the Monitor Screen

■ Screen Display in the Frequency Monitoring Mode

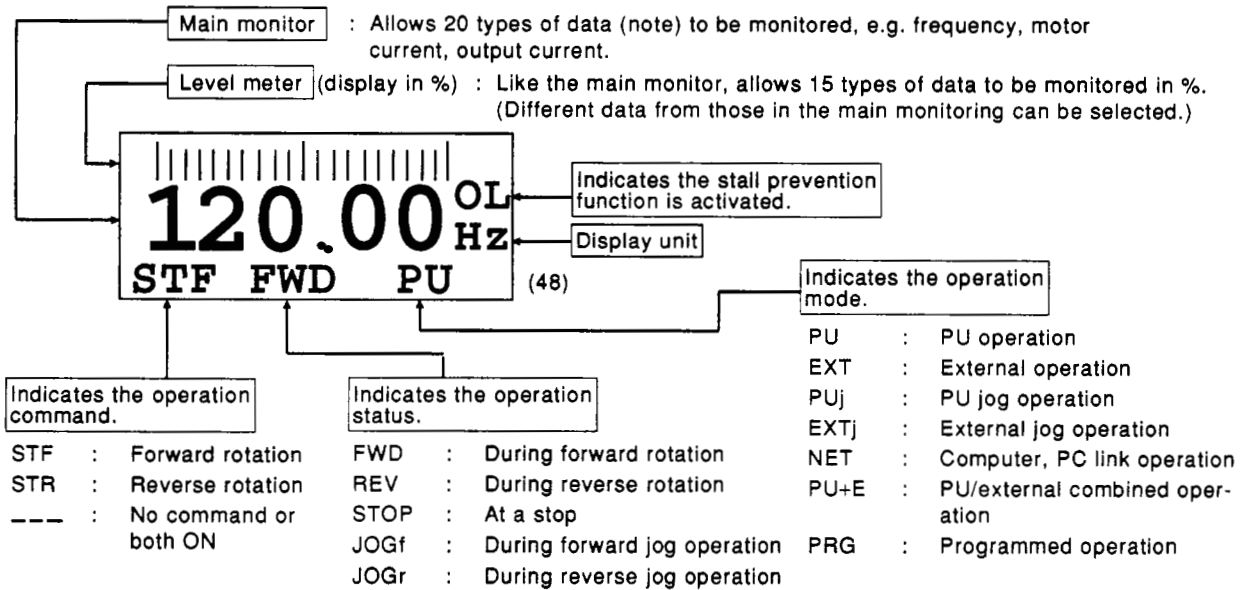

Note: For more information on the 20 monitor screens available, refer to page 64 (monitor/output signal selection).

- The following modes are displayed on the parameter unit:

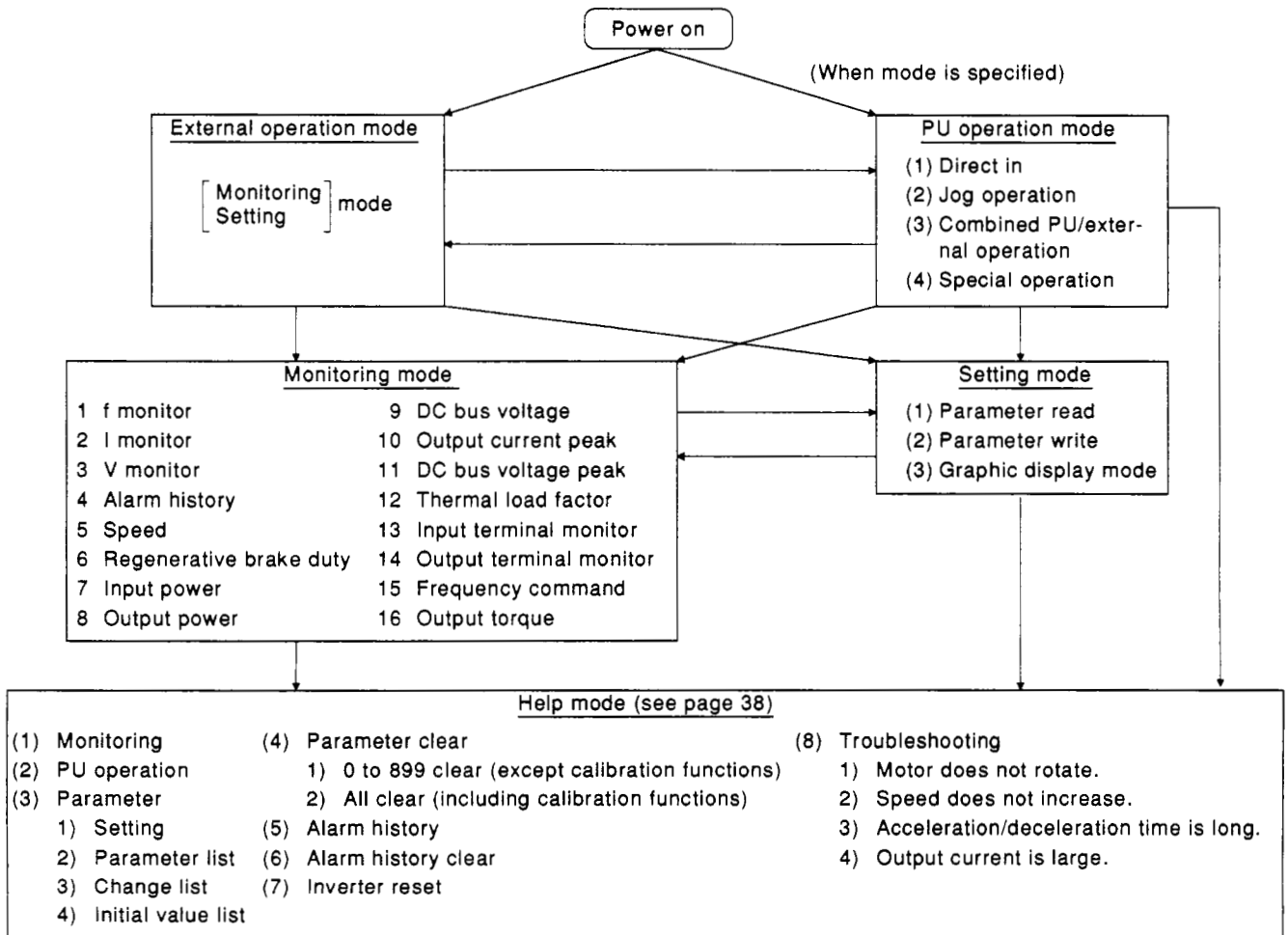

Changing or Checking the Function (Parameter) Set Values

By changing the parameters of the inverter, the function and performance of the inverter and motor can be matched to the application. The factory-set values need not be changed when they are appropriate. The parameter numbers are represented Pr. .

Operating Procedures

(1) Directly entering the Pr. number, calling and setting the parameter

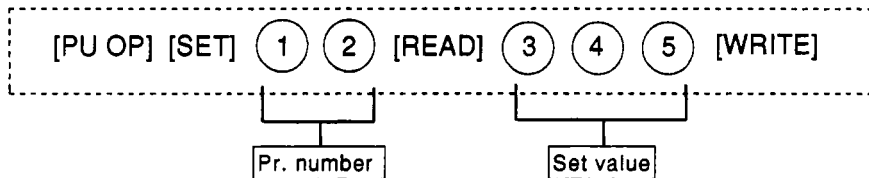

* The function names (abbreviation) of parameters Pr. 0 to Pr. 9, which are most often used, are given below the numerals on the numeral keys (0 to 9).

Setting example Setting Pr. 7 (acceleration time) to 3.5 seconds.

Operation and Keying Procedure	PU Screen Display	Remarks
[PU OP] [SET] [READ]	<div style="border: 1px solid black; padding: 5px;"> SETTING MODE Set Pr.NO. FOR PR.List <HELP> </div> (49)	
⑦	<div style="border: 1px solid black; padding: 5px;"> SETTING MODE Pr.NO. 7 <READ> </div> (50)	
[READ]	<div style="border: 1px solid black; padding: 5px;"> 7 Acc.T1 Current set 5.0S value 0~3600 Setting range (51) </div>	To call the parameter function graphically
* ③ [READ] ⑤ [WRITE]	<div style="border: 1px solid black; padding: 5px;"> 7 Acc.T1 3.5S Completed </div> (52)	(55)
MONITOR	<div style="border: 1px solid black; padding: 5px;"> <div style="text-align: center; font-size: 2em;">0.00</div> <div style="text-align: center;">Hz</div> <div style="text-align: center;">--- STOP PU</div> </div> (53)	To move to the next parameter number (Pr. 8 in this case), press the [SHIFT] key.
or [SHIFT]	<div style="border: 1px solid black; padding: 5px;"> 8 Dec.T1 5.0S 0~3600 </div> (54)	After the setting is complete, press the [SHIFT] key to move to the next parameter.

Changing or Checking the Function (Parameter) Set Values

(2) Calling the parameter list and setting the parameter

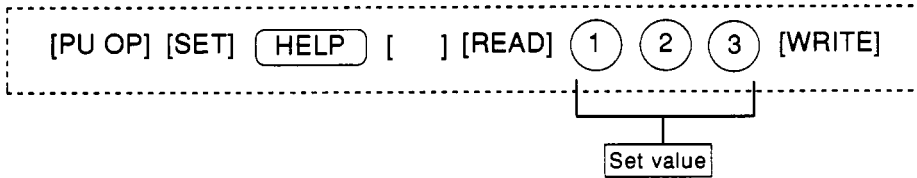

Setting example Setting Pr. 13 (starting frequency) to 1Hz.

Operation and Keying Procedure	PU Screen Display	Remarks
[PU OP] [SET] [READ]	<div style="border: 1px solid black; padding: 5px; width: fit-content;"> SETTING MODE Set Pr.NO. FOR PR.List <HELP> </div> (56)	
[HELP]	<div style="border: 1px solid black; padding: 5px; width: fit-content;"> 0*Trq.Bst1 1 Max.F1 2 Min.F1 3 VFbaseF1 </div> (57)	
Note: <div style="border: 1px dashed black; padding: 2px; display: inline-block;"> [SHIFT] [▼][▼][▼] </div> [▼]	<div style="border: 1px solid black; padding: 5px; width: fit-content;"> 12 DC Br.V 13*Start F 14 Load VF 15 JOG F </div> (58)	
[READ]	<div style="border: 1px solid black; padding: 5px; width: fit-content;"> 13 Start F 0.50Hz 0-60 </div> (59)	To call the parameter function graphically
① [WRITE]	<div style="border: 1px solid black; padding: 5px; width: fit-content;"> 13 Start F <div style="background-color: black; color: white; padding: 2px; display: inline-block;">1.00Hz</div> Completed </div> (60)	<div style="border: 1px solid black; padding: 5px; width: fit-content;"> <div style="display: flex; justify-content: space-between;"> <div> [HELP] → [CLEAR] ← </div> <div style="text-align: center;"> Pr 13 0.50 Hz </div> </div> <p>(Returns to the previous screen)</p> </div> (63)
[MONITOR]	<div style="border: 1px solid black; padding: 5px; width: fit-content;"> <div style="text-align: center; font-size: 24px;">0.00</div> Hz --- STOP PU </div> (61)	
or [SHIFT]	<div style="border: 1px solid black; padding: 5px; width: fit-content;"> 14 Load VF 0 * 0, 1, 2, 3 </div> (62)	After the setting is complete, press the [SHIFT] key to move to the next parameter.

Note: Hold down the [SHIFT] key and press the [▼] key.

Applying the Help Function

By pressing HELP in any PU operation mode, the inverter gives the operation guide.

- | | | | | |
|-----|-----------------------------|------|------|---------------------------|
| (1) | Monitoring mode | HELP | → | Monitoring (item) list |
| (2) | Setting mode | HELP | → | Parameter (item) list |
| | (before Pr. number setting) | | | |
| (3) | Setting mode | HELP | → | Graphic display |
| | (after Pr. number setting) | | | |
| (4) | PU operation mode | HELP | → | Key operation explanation |
| (5) | General operation mode | HELP | HELP | → Help (item) list |

(1) Help function in the monitoring mode

Operating and Keying Procedure	PU Screen Display	Remarks
<p>PU OP MONITOR</p> <p>HELP</p>	<div style="border: 1px solid black; padding: 5px; text-align: center;"> <p>0.00 Hz</p> <p>--- STOP PU</p> </div> <p style="text-align: right;">(64)</p> <div style="border: 1px solid black; padding: 5px;"> <p>1 Frequency</p> <p>2 Current</p> <p>3 Voltage</p> <p>4 Alarm His</p> </div> <p style="text-align: right;">(65)</p>	<p>This operation may be performed on any monitor screen. Also this operation may be performed during inverter operation.</p>

- Move the cursor (indicated by →) using the [▲] (or [▼]) key, then press the [READ] key to select the corresponding monitor item.
- * Furthermore, press the [WRITE] key to store the data so that this screen is displayed first in the monitoring mode after the monitor screen has been switched to another display screen.

Applying the Help Function

(2) Help function in the setting mode (Part 1)

Operating and Keying Procedure	PU Screen Display	Remarks
<p>[PU OP] [SET]</p>	<pre>SETTING MODE Set Pr.NO. FOR Pr.List <HELP></pre> <p>(66)</p>	
<p>[HELP]</p>	<pre>0*Trq.Bst1 1 Max.F1 2 Min.F1 3 VFbaseF1</pre> <p>(67)</p>	

Move the cursor (→) and press the [READ] key to select any parameter.

(3) Help function in the setting mode (Part 2) Operation example Pr. 0 (torque boost)

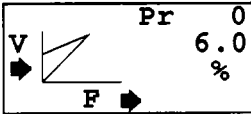
Operating and Keying Procedure	PU Screen Display	Remarks
<p>[PU OP] [SET]</p>	<pre>SETTING MODE Set Pr.NO. FOR Pr.List <HELP></pre> <p>(68)</p>	
<p>[0] [READ]</p>	<pre>0 Trq.Bst1 6.0% → 0~30</pre> <p>(69)</p>	
<p>[HELP]</p>	 <pre>Pr 0 6.0 %</pre> <p>(70)</p>	The function of the corresponding parameter is displayed graphically.

- On this screen, press the SHIFT key to graphically display the parameter of the next number.

(4) Help function in the PU operation mode (before frequency setting)

Operating and Keying Procedure	PU Screen Display	Remarks
<p>[PU OP]</p>	<pre>DIRECTLY Set 50.00HZ → 0~400</pre> <p>(71)</p>	
<p>[HELP]</p>	<pre>KEY OPERATION Fset: 0-9 Then: WRITE Then: FWD, REV</pre> <p>(72)</p>	<p>Key operation explanation screen</p> <ul style="list-style-type: none"> • To set the frequency (f), use the 0 to 9 numeral keys. • Then press the [WRITE] key. • Furthermore press the [FWD] or [REV] key to start.

Applying the Help Function

(5) Calling the help menu

Press the **HELP** key twice in any operation mode to call the help menu, with which various functions can be executed.

Help Menu

Function Name	Description
1. MONITOR	Displays the monitoring list (items).
2. PU OPERATION	Informs how to perform PU operation and PU-assisted jog operation via direct input (direct setting from the ten-key pad).
3. PARAMETER	Allows any of the following item executing methods to be selected: 1) Parameter setting 2) Parameter list calling 3) Parameter change list (list of parameters which have been changed from the factory-set values) 4) Initial value list (list of parameters set at the factory)
4. PARAMETER CLEAR	Either of the following two items can be selected: 1) Parameter clear (returns all parameters to the factory-set values with the exception of calibration parameters Pr. 900 to 905) 2) All parameter clear (returns all parameters to the factory-set values)
5. ALARM HISTORY	Displays past eight alarms.
6. ALARM HISTORY CLEAR	Clears the above alarms.
7. INVERTER RESET	Resets the inverter.
8. TROUBLESHOOTING	The inverter displays the most likely cause of mismatch in inverter operation with operation/setting or the cause of inverter fault.

Applying the Help Function

Operations in the help menu not previously described will now be described.

(5) -1) Parameter change list

Displays only the set values of the parameters which have been changed from the factory-set values.

Operating and Keying Procedure	PU Screen Display	Remarks
<p>PU OP HELP HELP</p>	<pre> 1▶MONITOR 2 PU Oper 3 Pr.List 4 Pr.Clear ▾ (73) </pre>	Help menu screen
<p>[▼][▼][READ]</p>	<pre> 1 SettingMODE 2 Pr.List 3▶Set Pr.List 4 Def.Pr.List (74) </pre>	Help menu screen regarding the parameters
<p>[▼][▼][READ]</p>	<pre> SET Pr.LIST Pr 0▶ 8.0 Pr 1 - Pr 2 - (75) </pre>	Only the parameters which have been changed in setting are displayed on part of the screen. (The screen shown on the left indicates an example of Pr. 0 whose value has been changed to 8%.)

(5) -2) Initial value list

Displays a list of the factory-set values of the parameters. This function is convenient when a typical set value is lost.

Operating and Keying Procedure	PU Screen Display	Remarks
<p>PU OP HELP HELP</p>	<pre> 1▶MONITOR 2 PU Oper 3 Pr.List 4 Pr.Clear ▾ (76) </pre>	
<p>[▼][▼][READ]</p>	<pre> 1 SettingMODE 2 Pr.List 3 Set Pr.List 4▶Def.Pr.List (77) </pre>	
<p>[▼][▼][▼][READ]</p>	<pre> DEF.Pr.LIST Pr 0▶ 6.0 Pr 1 120.00 Pr 2 0.00 (78) </pre>	
<p>[READ]</p>	<pre> 0 Trq.Bst1 6.0% ▶ 0~30 (79) </pre>	Enters the setting mode of the parameter at the cursor position.

Applying the Help Function

(5) -3) Parameter clear and all parameter clear

Parameter clear and all parameter clear differ as follows: The parameter clear operation does not clear the calibration parameters of Pr. 900 to Pr. 905, but the all parameter clear operation clears all parameters.

Clear indicates that the parameters are set to the factory-set values.

Operating and Keying Procedure	PU Screen Display	Remarks
<p>[PU OP] [HELP] [HELP]</p> <p>[▼][▼][▼][READ]</p> <p>[READ]</p> <p>[WRITE]</p> <p>[▼][READ]</p> <p>[WRITE]</p>	<p>1*MONITOR 2 PU Oper 3 Pr.List 4 Pr.Clear (80)</p> <p>1*Clear Pr. 2 Clear All 3 Clear None /◆▲♥+<READ> (81)</p> <p>Clear Pr. Exec<WRITE> Cancel<CLEAR> (82)</p> <p>Clear Pr. Executing (83)</p> <p>CLEAR ALL Pr. Exec<WRITE> Cancel<CLEAR> (84)</p> <p>CLEAR ALL Pr. Executing (85)</p>	<p></p> <p>Press the [PU OP], [CLEAR] or other key to return to another mode.</p> <p>Press the [PU OP], [CLEAR] or other key to return to another mode.</p>

Applying the Help Function

(5) -4) Alarm history and alarm history clear

Operating and Keying Procedure	PU Screen Display	Remarks
<p>[PU OP] [HELP] [HELP]</p> <p>Hold down [SHIFT] and press [▼]</p> <p>[READ]</p> <p>[▼] [READ]</p> <p>[WRITE]</p>	<p>1*MONITOR 2 PU Oper 3 Pr.List 4 Pr.Clear (86)</p> <p>5*Alarm Hist△ 6 AlarmClear 7 Inv.Reset 8 T/Shooting (87)</p> <p>1 UVT 5 2 UVT 6 3 7 4 8 (88)</p> <p>ALARM CLEAR Exec<WRITE> Cancel<CLEAR> (89)</p> <p>ALARM CLEAR Completed (90)</p>	<p>Alarm history screen</p> <p>Press the [PU OP] or [SHIFT] key to return to another mode.</p>

* The alarm history can also be displayed by pressing the SHIFT key in the monitoring mode. (See page 32.)

(5) -5) Inverter reset

If any protective function of the inverter has tripped the inverter, the following operation allows the inverter to be reset via the keypad.

The inverter can also be reset by switching the power off or connecting the terminals RES-SD.

Operating and Keying Procedure	PU Screen Display	Remarks
<p>[PU OP] [HELP] [HELP]</p> <p>Hold down [SHIFT] and press [▼] further [▼] [▼] [READ]</p> <p>[WRITE]</p>	<p>1*MONITOR 2 PU Oper 3 Pr.List 4 Pr.Clear (91)</p> <p>INV. RESET Exec<WRITE> Cancel<CLEAR> (92)</p> <p>0.00 Hz --- STOP EXT (93)</p>	<p>When another monitor item has been selected on the monitoring first-priority screen, that monitor screen is displayed.</p>

Applying the Help Function

(5) -6) Troubleshooting

Select this mode when the inverter operation appears faulty. The most likely cause of the fault is displayed. This operation mode can be selected during the inverter operation (PU operation, external operation), alarm trip (protection activated), etc.

Operating and Keying Procedure	PU Screen Display	Remarks
<p>HELP HELP</p> <p>Hold down SHIFT and press [▼] further [▼][▼][▼]</p> <p>READ</p>	<pre> 1*MONITOR 2 PU Oper 3 Pr.List 4 Pr.Clear ▾ (94) 5*Alarm HistⓂ 6 AlarmClear 7 Inv.Reset 8 T/Shooting (95) 1 M.Not Run 2 M.Spd Error 3 M.A/Dec Err 4 M.Curr.High (96) </pre>	<p>Symptom menu. Move the cursor to the item matching the fault and press the READ key.</p>

The fault on each display screen are described below.

■ M.NOT RUNNING(Motor does not rotate)

**M.NOT RUNNING
ALARM
Indicated
<SHIFT>** (97)

The inverter has alarm-tripped (protection activated), resulting in output shut-off. Press the [SHIFT] key to display the cause of protection activated.

**M.NOT RUNNING
NO I/P Power
or Phase Loss** (98)

The main circuit power of the inverter is lost, or open phase has occurred in the power supply. Check the power supply.

**M.NOT RUNNING
STF, STR
both are OFF
or ON** (99)

Both start signals STF and STR are ON or OFF.

**M.NOT RUNNING
MRS is ON** (100)

The output shut-off input terminal MRS is ON.

**M.NOT RUNNING
SetF<StartF
Pr.13** (101)

The inverter starting frequency (Pr. 13) set value is higher than the current set frequency.

Applying the Help Function

M.NOT RUNNING
AU is OFF

(102)

The current input select terminal AU remains OFF. (Not ON)

M.NOT RUNNING
NO Command
From PU

(103)

Neither of the FWD and REV keys are ON in the PU operation mode.

M.NOT RUNNING
MaX.F1<StartF
Pr.1 Pr.13

(104)

The inverter cannot be started because the inverter starting frequency (Pr. 13) value is higher than the maximum frequency (Pr. 1).

M.NOT RUNNING
EnableFR Set
See Pr.78

(105)

The inverter cannot be started because the forward or reverse rotation has been inhibited by the value set in Pr. 78.

M.NOT RUNNING
Current Limit
Activated
<SHIFT>

(106)

The inverter cannot be started since the current limit function is operating. Press the SHIFT key to display the assumed cause of activating the current limit function.

M.NOT RUNNING
TS Control
Standby Mode

(107)

The inverter cannot be started because it is the stop period in the programmed operation mode.

M.NOT RUNNING
Under
PI Control

(108)

The inverter is not started because the operation of PI control has resulted in a condition under which the inverter need not be started.

M.NOT RUNNING
CS is OFF
See Pr.57

(109)

Restart cannot be made since the automatic restart after instantaneous power failure select terminal CS is OFF.

Currently it is assumed to be after instantaneous power failure or in the commercial power supply switch-over operation mode.

Applying the Help Function

■M.SPEED ERROR(Speed does not match the running frequency set value)

```
M.SPEED ERROR
SetF>MaxF1/F2
60.00 Pr1/18
Hz
```

(110)

Since the running frequency set value is higher than the maximum frequency (Pr. 1) set value, the running frequency remains at the maximum frequency.

```
M.SPEED ERROR
SetF<Min.F1
60.00 Pr.2
Hz
```

(111)

Since the running frequency set value is lower than the minimum frequency (Pr. 2) set value, the running frequency has been risen to the minimum frequency.

```
M.SPEED ERROR
Fjump Working
See Pr.31→36
SetF= 60.00Hz
```

(112)

Since the running frequency set value is within the frequency jump setting range, the running frequency has jumped.

```
M.SPEED ERROR
Current Limit
Activated
<SHIFT>
```

(113)

The current limit function has been activated and forced the running frequency to reduce. Press the SHIFT key to display the cause of activating the current limit function.

```
M.SPEED ERROR
Under
PI Control
```

(114)

The operation of PI control has caused the running frequency to be offset from the set value.

■M.A/Dec Err

(Acceleration/deceleration time is longer than the value set in Pr.7/Pr. 8)

```
Set 5.0S
0→ 60.00Hz
Set 5.0S
60.00Hz→0
```

(115)

Acceleration time set value (Pr. 7) is displayed.

Frequency reached in the above set time (acceleration/deceleration reference frequency, Pr. 20) is displayed.

Deceleration time set value (Pr. 8) is displayed.

Frequency from which deceleration is made in the above set time (acceleration/deceleration reference frequency, Pr. 20) is displayed.

```
▲ ▼
Stll Pv.ON? Δ
Set Too Low?
Load Too Big?
Pr.22 Error?
```

(116)

Assumed cause of longer acceleration/deceleration time than the set value is displayed.

- Stall prevention function (current limit function) is implemented.
- Set time is too short.
- Motor load is heavy.
- Pr. 22 (stall prevention operation level) setting error.

Applying the Help Function

■ M.Curr.High (Inverter output current value is larger than normal)

Inv. Output
60.00HZ
10A 230V
<SHIFT> (117)

First, the running frequency, output current and output voltage of the inverter are displayed.

Press the **SHIFT** key to display the assumed cause of large output current.

SHIFT

Low Impedance
Motor?
Reduce TrqBst
Pr. 0, 38, 46 (118)

Is the motor a special motor other than the general-purpose 3-phase induction motor?

If so, reduce the torque boost set value.

Related parameters: Pr. 0, 38, 46



Low Trq
Motor?
Reduce TrqBst
Pr. 0, 38, 46 (119)

Is the motor a constant-torque motor (motor for inverter)?

If so, reduce the torque boost set value.

Related parameters: Pr. 0, 38, 46



Trq. Bst
Setting Err?
See Pr. 0, 38,
46 (120)

Since the torque boost set value may be inappropriate, check the following relevant parameters:

Related parameters: Pr. 0, 38, 46



V/F Setting
Error?
See Pr. 3, 14,
19, 47 (121)

Since the V/F pattern setting may be inappropriate, check the following relevant parameters:

Related parameters: Pr. 3, 14, 19, 47



Load Too Big?
OutPut
Phase Loss? (122)

The load may be too heavy.

An open phase may have occurred between the inverter and motor.

■ If the fault could not be identified by the above operation.

Inv. Output
60.00HZ
10A 230V
<SHIFT> (123)

If the cause of the fault could not be found in the inverter, the current running frequency, output current and output voltage are displayed on the screen.

Press **SHIFT** to display the relevant assumed cause.

Calibrating the Frequency Meter

The PU allows the calibration (adjustment) of a meter connected across the meter connection terminal FM-SD or AM-5 of the inverter.

When a digital meter is used, the PU allows the frequency of the pulse train output signal to be adjusted (across terminals FM-SD).

(1) Calibration of the FM-SD output

- Preparation**
- (1) Connect a meter across inverter terminals FM-SD. (Note polarity. FM is the positive terminal.)
 - (2) When a calibration resistor has already been connected, adjust the resistance value to zero or remove the resistor.
 - (3) When 1 or 2 has been set in Pr. 54 to select the running frequency or inverter output current as the output signal, preset in Pr. 55 or Pr. 56 the running frequency or current value at which the output signal is 1440Hz. This 1440Hz normally makes the meter full-scale.
- The motor need not be connected.

Operating Procedure (The following example indicates that the meter is calibrated to the running frequency of 60Hz.)

Operating and Keying Procedure	PU Screen Display	Remarks
<p> <input type="button" value="PU OP"/> <input type="button" value="SET"/> <input type="button" value="9"/> <input type="button" value="0"/> <input type="button" value="0"/> <input type="button" value="READ"/> </p> <p>Set the running frequency.</p> <p> <input type="button" value="6"/> <input type="button" value="0"/> <input type="button" value="WRITE"/> </p> <p><input type="button" value="FWD"/></p> <p>Adjust the frequency meter reading to a predetermined position using the [▲] or [▼] key.</p> <p><input type="button" value="WRITE"/></p> <p><input type="button" value="MONITOR"/></p>	<p> 900 FM Tune Run Inverter Set ● 0.00Hz PU (124) </p> <p> 900 FM Tune Run Inverter Set 60.00Hz PU (125) </p> <p> 900 FM Tune MntrF 60.00Hz ▲▼◀<WRITE>PU (126) </p> <p> 900 FM Tune MntrF 60.00Hz ▲▼◀<WRITE>PU (127) </p> <p> 900 FM Tune Completed <MONITOR> (128) </p> <p> ┌──────────┐ │ 60.00 Hz │ └──────────┘ STF FWD PU (129) </p>	<p>The current PU set frequency is displayed</p> <p>Forward operation is performed at 60Hz.</p> <p>The frequency meter reading moves.</p> <p>Calibration is complete.</p>

Note: This calibration (Pr. 900) is only valid when any of 1 to 3, 5 to 14, 17, 18 and 21 has been set in Pr. 54 to output a signal to terminal FM. When any other value has been set (signal output to terminal AM has been selected in Pr. 54), the absence of Pr. 900 is displayed on the screen as soon as this parameter is selected by the above operation.

Calibrating the Frequency Meter

(2) Calibration of the AM-5 output

- Preparation**
- (1) Connect a meter of 0-10VDC across inverter terminals AM-5. (Note the polarity. AM is the positive terminal.)
 - (2) When 101 or 102 has been set in Pr. 54 to select the running frequency or inverter output current as the output signal, preset in Pr. 55 or Pr. 56 the running frequency or current value at which the output signal is 10V.

Operating Procedure (The following example indicates that the meter is calibrated to the running frequency of 60Hz.)

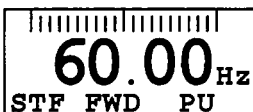
Operating and Keying Procedure	PU Screen Display	Remarks
<p> <input type="button" value="PU OP"/> <input type="button" value="SET"/> <input type="button" value="9"/> <input type="button" value="0"/> <input type="button" value="1"/> <input type="button" value="READ"/> </p> <p>Set the running frequency.</p> <p> <input type="button" value="6"/> <input type="button" value="0"/> <input type="button" value="WRITE"/> </p> <p><input type="button" value="FWD"/></p> <p>Adjust the frequency meter reading to a predetermined position using the [▲] or [▼] key.</p> <p><input type="button" value="WRITE"/></p> <p><input type="button" value="MONITOR"/></p>	<div style="border: 1px solid black; padding: 5px; margin-bottom: 5px;"> <p>901 AM Tune Run Inverter Set ● 0.00Hz PU (130)</p> </div> <div style="border: 1px solid black; padding: 5px; margin-bottom: 5px;"> <p>901 AM Tune Run Inverter Set 60.00Hz PU (131)</p> </div> <div style="border: 1px solid black; padding: 5px; margin-bottom: 5px;"> <p>901 AM Tune MntrF 60.00Hz ◆◀▶<WRITE>PU (132)</p> </div> <div style="border: 1px solid black; padding: 5px; margin-bottom: 5px;"> <p>901 AM Tune MntrF 60.00Hz ◆◀▶<WRITE>PU (133)</p> </div> <div style="border: 1px solid black; padding: 5px; margin-bottom: 5px;"> <p>901 AM Tune Completed <MONITOR> (134)</p> </div> <div style="border: 1px solid black; padding: 5px;"> <p>  60.00 Hz STF FWD PU (135) </p> </div>	<p>The current PU set frequency is displayed</p> <p>Forward operation is performed at 60Hz.</p> <p>The frequency meter reading moves.</p> <p>Calibration is complete.</p>

Note: This calibration (Pr. 901) is only valid when any of 101 to 103, 105 to 114, 117, 118 and 121 has been set in Pr. 54 to output a signal to terminal AM. When any other value has been set (signal output to terminal FM has been selected in Pr. 54), the absence of Pr. 901 is displayed on the screen as soon as this parameter is selected by the above operation.

Adjusting the Bias and Gain of the Frequency Setting Signal

The bias and gain functions are used to adjust the relationship between the input signal entered from outside the inverter to set the output frequency, e.g. 0 to 5VDC, 0 to 10VDC or 4 to 20mADC, and the output frequency.

Parameters Pr. 902 to Pr. 905 are used for this adjustment.

Adjustment examples

- Frequency setting voltage bias setting
Set the output frequency to 10Hz at the set voltage of 0V.
- Frequency setting voltage gain setting
Set the output frequency to 60Hz at the set voltage of 5V.

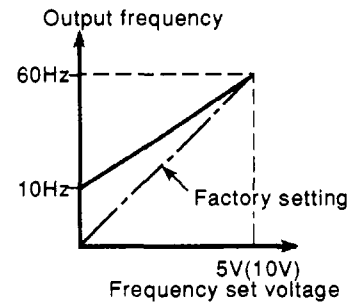

Preparation: Set 1 (factory-set value) in Pr. 73 to select input 0-5V for terminal 2.

Operating and Keying Procedure	PU Screen Display	Remarks
<p>PU OP SET</p> <p>9 0 2 READ (note)</p> <p>1 0 WRITE</p>	<pre>902 EXTvbias ▶ 0.00Hz Set ● <WRITE> EXT ▶ <READ></pre> <p>(136)</p> <pre>902 EXTvbias 10.00Hz Completed</pre> <p>(137)</p>	<p>A voltage does not need to be applied across terminals 2-5.</p> <p>The bias setting is 10Hz.</p> <p>If a voltage is being applied, the bias setting is as shown above.</p>
<p>If you want to set the bias against the set voltage across terminals 2-5,</p> <p>READ</p> <p>WRITE</p>	<pre>902 EXTvbias ▶ 10.00Hz - 0.5% EXT - 0.5%</pre> <p>(138)</p> <pre>902 EXTvbias ▶ 10.00Hz - 0.5% EXT - 0.5%</pre> <p>(139)</p>	<p>The bias setting with the set voltage should be made in the following procedure.</p> <p>Preceding set value is displayed.</p> <p>Current set voltage across terminals 2-5 is displayed in %. The displayed value is changed according to the set voltage.</p> <p>(Value selected in Pr. 73 (5V in this example) is 100%)</p> <p>If 1V has been set, the bias setting is as follows:</p>

(Continued)

Adjusting the Bias and Gain of the Frequency Setting Signal

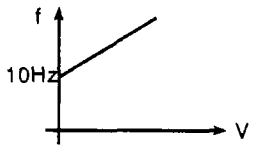
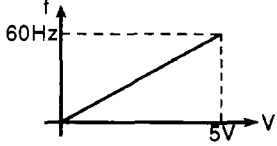
Operating and Keying Procedure	PU Screen Display	Remarks
<p>WRITE</p> <p>SHIFT</p> <p>WRITE (note)</p>	<p>902 EXTVbias 10.00Hz - 0.2% Completed (139)</p> <p>903 EXTVgain ➤ 60.00Hz Set ➤ <WRITE> EXT ➤ <READ> (140)</p> <p>903 EXTVgain 60.00 Hz Completed</p>	<p>0.0% may not be displayed. The bias setting is as follows:</p>  <p>A voltage does not need to be applied across terminals 2-5, and gain setting is made with 5V (or 10V) in the inverter.</p> 
<p>If you want to set the gain against the set voltage across terminals 2-5,</p> <p>READ</p> <p>WRITE</p> <p>WRITE</p>	<p>903 EXTVgain ➤ 60.00Hz 97.1% EXT 99.0% (141)</p> <p>903 EXTVgain 60.00Hz ➤ 97.1% EXT 99.0%</p> <p>903 EXTVgain 60.00Hz 99.6% Completed (142)</p>	<p>The gain setting with the set voltage should be made in the following procedure.</p> <p>Factory-set value (Preceding set value is displayed.)</p> <p>Current set voltage across terminals 2-5 is displayed in %. The displayed value is changed according as the set voltage.</p> <p>(Value selected in Pr. 73 (5V in this example) is 100%)</p> <p>Set voltage across terminals 2-5.</p> <p>100.0% may not be displayed.</p>

Note: • Pr. 904, Pr. 905 (bias and gain of frequency setting current signal) can also be set in a similar manner.
 • Pr. 903 and Pr. 905 (gains) remain unchanged if Pr. 20 (acc./dec. reference f) is changed.

6. PARAMETER UNIT

6.5 Parameters

Parameter List

Function	Parameter Number	Name	Screen Display	Note 4	Setting Range	Minimum Setting Increment	Factory Setting	Refer To:	
Basic functions	0	Torque boost (manual)	Trq.Bst1	0	0 to 30%	0.1%	6%/3% (note 1)	56	
	1	Maximum frequency	Max.F1		0 to 120Hz	0.01Hz	120Hz		
	2	Minimum frequency	Min.F1		0 to 120Hz		0Hz		
	3	Base frequency	VFbaseF1		0 to 400Hz		60Hz		
	4	Multi-speed setting (high speed)	PresetF1		0 to 400Hz		60Hz		
	5	Multi-speed setting (middle speed)	PresetF2		0 to 400Hz		30Hz		
	6	Multi-speed setting (low speed)	PresetF3		0 to 400Hz		10Hz		
	Standard operation functions	7	Acceleration time	Acc.T1		0 to 3600 seconds/ 0 to 360 seconds	0.1 seconds/ 0.01 seconds	5 seconds/ 15 seconds (note 1)	57
		8	Deceleration time	Dec.T1		0 to 3600 seconds/ 0 to 360 seconds	0.1 seconds/ 0.01 seconds	5 seconds/ 15 seconds (note 1)	
9		Electronic thermal O/L relay	Set THM		0 to 500A	0.01A	Rated output current		
		10	DC injection brake operation frequency	DC Br.F		0 to 120Hz, 9999	0.01Hz	3Hz	58
		11	DC injection brake operation time	DC Br.T		0 to 10 seconds	0.1 seconds	0.5 seconds	
		12	DC injection brake voltage	DC Br.V		0 to 30%	0.1%	6%/3% (note 1)	
		13	Starting frequency	Start F		0 to 60Hz	0.01Hz	0.5Hz	
		14	Applied load selection	Load VF	0	0, 1, 2, 3	1	0	59
		15	Jog frequency	JOG F		0 to 400Hz	0.01Hz	5Hz	
	16	Jog acceleration/ deceleration time	JOG T		0 to 3600 seconds/ 0 to 360 seconds	0.1 seconds/ 0.01 seconds	0.5 seconds		
	17	External thermal O/L relay input	JOG/OH		0, 1, 2, 3	1	0	60	
	18	High-speed maximum frequency	Max.F2		120 to 400Hz	0.01Hz	120Hz		
	19	Base frequency voltage	VFbase V		0 to 1000V, 9999	0.1V	9999		
	20	Acceleration/ deceleration reference frequency	Acc/DecF		1 to 400Hz	0.01Hz	60Hz		
	21	Acceleration/ deceleration time increments	Incr.T		0, 1	1	0		
22	Stall prevention operation level	Stil Pv1		0 to 200%	0.1%	150%			
	23	Stall prevention operation level at double speed	Stil Pv2		0 to 200%, 9999	0.1%	9999	60	
	24	Multi-speed setting (speed 4)	PresetF4		0 to 400Hz, 9999	0.01Hz	9999		
	25	Multi-speed setting (speed 5)	PresetF5						
	26	Multi-speed setting (speed 6)	PresetF6						
	27	Multi-speed setting (speed 7)	PresetF7						
	28	Multi-speed input compensation	Pre.Comp		0, 1	1	0		

Note 1: The set value depends on the inverter capacity: (7.5K and down)/(11K and up).

Note 2: in the Screen Display section, f indicates a frequency, V a voltage, and I a current.

6. PARAMETER UNIT

Func tion	Parameter Number	Name	Screen Display	Note 4	Setting Range	Minimum Setting Increment	Factory Setting	Refer To:
Standard operation functions	29	Acceleration/ deceleration pattern	Acc/DecP		0, 1, 2, 3	1	0	60
	30	External brake resistor selection	Br.Set		0, 1	1	0	
	31	Frequency jump 1A	Fjump 1A		0 to 400Hz, 9999	0.01Hz	9999	61
	32	Frequency jump 1B	Fjump 1B					
	33	Frequency jump 2A	Fjump 2A					
	34	Frequency jump 2B	Fjump 2B					
	35	Frequency jump 3A	Fjump 3A					
	36	Frequency jump 3B	Fjump 3B					
	37	Speed display	Dispunit		2 to 10, 11 to 9998	1	4	
	38	Automatic torque boost	A.TrqBst	0	0 to 200%	0.01%	0	
39	Automatic torque boost operation start- ing current	NoLoad I	0	0 to 500A	0.01A	0		
Multi-function output terminal functions	40	Output terminal assignment	Selectop		0 to 9999	1	1234	
	41	Up-to-frequency sensitivity	SU Range		0 to 100%	0.1%	10%	
	42	Output frequency detection	SetFU FW		0 to 400Hz	0.01Hz	6Hz	
	43	Output frequency detection at reverse rotation	SetFU RV		0 to 400Hz, 9999	0.01Hz	9999	
Second functions	44	Second acceleration/ deceleration time	Ac/DecT2		0 to 3600 seconds/ 0 to 360 seconds	0.1 seconds/ 0.01 seconds	5 seconds	63
	45	Second deceleration time	Dec.T2		0 to 3600 seconds/ 0 to 360 seconds, 9999		9999	
	46	Second torque boost	Trq.Bst2	0	0 to 30%, 9999	0.1%		
	47	Second V/F (base frequency)	VFbaseF2		0 to 400Hz, 9999	0.01Hz		
	48	Second stall prevention operation level (current)	Stall2 I		0 to 200%	0.1%	150%	
	49	Second stall prevention operation level (frequency)	Stall2 F		0 to 400Hz	0.01Hz	0Hz	
50	Second output frequency detection	SetFU 2		0 to 400Hz	0.01Hz	30Hz		
Display functions	51	Inverter LED display data selection	Set LED		1 to 14, 17, 18	1	1	64
	52	PU main display data selection	Set Main		0, 17 to 20	1	0	
	53	PU level display data selection	Set Lvl.		0 to 3, 5 to 14, 17, 18	1	1	
	54	FM terminal function selection	Set FM		1 to 3, 5 to 14, 17, 18, 21, 101 to 103, 105 to 114, 117, 118, 121	1	1	
	55	Frequency monitoring reference	CalbFM F		0 to 400Hz	0.01Hz	60Hz	
	56	Current monitoring reference	CalbFM I		0 to 500A	0.01A	Rated out- put current	
Automatic restart functions	57	Restart coasting time	RestrtT1		0 to 5 seconds, 9999	0.1 seconds	9999	65
	58	Restart cushion time	RestrtT2		0 to 5 seconds	0.1 seconds	1.0 seconds	
Additional functions	59	Remote setting function selection	Rmt Set		0, 1, 2	1	0	

6. PARAMETER UNIT

Func tion	Parameter Number	Name	Screen Display	Note 4	Setting Range	Minimum Setting Increment	Factory Setting	Refer To:
Operation selection functions	60	Intelligent mode selection	Int.Mode		0 to 6	1	0	66
	66	Stall prevention operation reduction starting frequency	Still coF		0 to 400Hz	0.01Hz	60Hz	67
	67	Number of retries at alarm occurrence	Retry No		0 to 10	1	0	
	68	Retry waiting time	Retry t		0 to 10 seconds, 9999	0.1 seconds	9999	
	69	Retry count display erasure	Retry N		0	—	0	
	70	Special regenerative brake duty	Br.Duty		0 to 15%/0 to 30%/0% (note 3)	0.1%	0%	
	71	Applied motor	SetMotor		0, 1, 2	1	0	
	72	PWM frequency selection	PWM F		2 to 14.5KHz	0.1KHz	14.5KHz	
	73	0 to 5V, 0 to 10V selection	Extf/10V		0 to 5, 10 to 15	1	1	68
	74	Response time for analog signal	IPfilter		0 to 8	1	1	
	75	Reset selection	RES Mode		0, 1, 2, 3	1	0	
	76	Alarm code output selection	Alarm OP		0, 1, 2, 3	1	0	69
	77	Parameter write disable selection	EnableWr		0, 1, 2	1	0	
	78	Reverse rotation prevention selection	EnableFR		0, 1, 2	1	0	
	79	Operation mode selection	ContMode		0 to 6	1	0	
	*80	Motor capacity	Motor KW		0.4 to 55kW, 9999	0.01kW	9999	
*81	Number of motor poles	Mpole No		2, 4, 6, 9999	1	9999		
Auxiliary functions	*82 to *88	Parameters set by manufacturer. Do not set.						—
	*89	Speed control gain	—		0 to 1000.0 %	0.1 %	100.0 %	77
	*90 to *99	Parameters set by manufacturer. Do not set.						
	*100 to *106	Parameters for inboard options. For details, refer to the option manual. Pr. 100 to 109 for V/F 5-points setting.						
	*107	Slip compensation selection	—		0, 10	□	0	77
	*108 to *113	Not defined						
	*114	Retry selection	—		0, 1, 2, 3, 4	1	0	67
	*115 to *149	Parameters for inboard options. For details, refer to the option manual.						
	*155	RT activated condition.	—		0, 10	1	0	70
	*156	Stall prevent. select. at regeneration.	—		0 to 31, 100	1	0	
*157	OL signal waiting time.	—		0 to 25 seconds, 9999	0.1 seconds	0		

Note 3: The setting range depends on the inverter capacity: (0.4K to 1.5K)/(2.2K to 7.5K)/(11K and up). The operation factor indicates %ED of the built-in brake transistor operation.

Note 4: Indicates the parameters which are ignored when the magnetic flux vector control mode is selected.

*: When the FR-PU01 is used, read and write of these parameters cannot be performed. (If performed, Err is displayed.) (Set the calibration function numbers 900 to 905 using C-1 to C-6.) For more information, see page 5.

Note 5: The parameters hatched allow their set values to be changed during operation if 0 (factory setting) has been set in Pr. 77 (parameter write disable).

6. PARAMETER UNIT

Func tion	Parameter Number	Name	Screen Display	Note 4	Setting Range	Minimum Setting Increment	Factory Setting	Refer To:			
Aux. functions	*158	AM terminal selec- tion	—		1 to 3, 5 to 14, 17, 18, 21, 9999	1	9999	—			
	*159	PWM f decrease at low speed	—		0, 1, 2, 3	1	0	70			
Calibration functions	900	FM terminal calibra- tion	FM Tune		—	—	—	71			
	901	AM terminal calibra- tion	AM Tune		—	—	—				
	902	Frequency setting voltage bias	ExtVbias		0 to 10V	0 to 60Hz	0.1V		0.01Hz	0V	0Hz
	903	Frequency setting voltage gain	ExtVgain							1 to 400Hz	5V
	904	Frequency setting current bias	ExtIbias		0 to 20mA	0 to 60Hz	0.1mA		0.01Hz	4mA	0Hz
	905	Frequency setting current gain	ExtIgain							1 to 400Hz	20mA

Explanation of the Parameters

Pr. 0-Pr. 6

Note: Pr. stands for parameter number.

Pr. 0 Setting of torque boost (manual)

- Allows the low-frequency range motor torque to be adjusted according to the load.

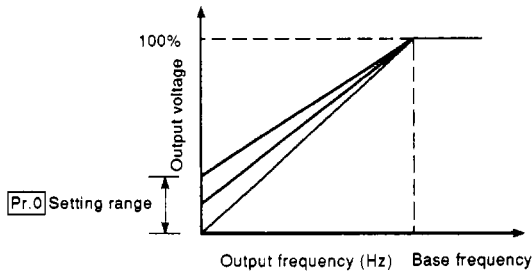

Note: Factory setting torque boost (manual)

-7.5K and less: 6% -11K and larger: 3%

Note: This parameter need not be set when the magnetic flux vector mode has been selected in Pr. 80 and Pr. 81.

Pr. 1 Pr. 2 Setting of maximum and minimum frequency limits

Limits

Pr. 1 Maximum frequency Pr. 2 minimum frequency

- Allow the output frequency to be clamped at the upper and lower limits.

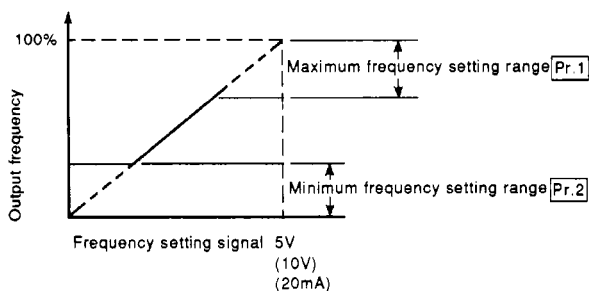

Note: Any frequency at or over 120Hz should be set in Pr. 18.

Pr. 3 Setting of base frequency

Pr. 3 Base frequency Pr. 19 Base frequency voltage

- Allows the base frequency (reference frequency at the rated torque of the motor) to be set as appropriate between 0 and 400Hz according to the motor rating.
- The setting of Pr. 19 (base frequency voltage) allows the optimal use of a motor of which rated voltage is lower than the power supply voltage of the inverter. This function is convenient for use of a 200V rated motor with a 230V power supply.

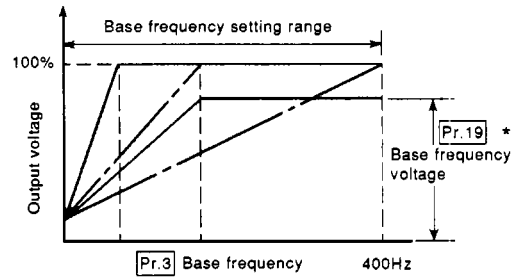

- * Setting 9999 (factory setting) in Pr. 19 makes the maximum output voltage identical to the power supply voltage.

Note: When the magnetic flux vector control mode has been selected in Pr. 80 and Pr. 81, Pr.19 is regarded as 200V (or 400V).

Pr. 4 Pr. 5 Pr. 6 Setting of multiple speeds

Pr. 4 3-speed setting (high speed)

Pr. 5 3-speed setting (middle speed)

Pr. 6 3-speed setting (low speed)

Pr. 24 multi-speed setting (speed 4)

Pr. 25 multi-speed setting (speed 5)

Pr. 26 multi-speed setting (speed 6)

Pr. 27 multi-speed setting (speed 7)

- Allows any speed to be selected by switching the external contact signal (across terminals RH/RM/RL and SD).
- Each speed (frequency) may be specified as appropriate between 0 and 400Hz during inverter operation. The speed may also be set using the [▲] and [▼] keys. (On releasing the [▲] and [▼] keys, the set frequency is stored, that is the [WRITE] key does not need to be pressed.)
- By using these functions with the jog frequency (Pr. 15), maximum frequency (Pr. 1) and minimum frequency (Pr. 2), up to 10 speeds can be set.

Pr. 6-Pr.12

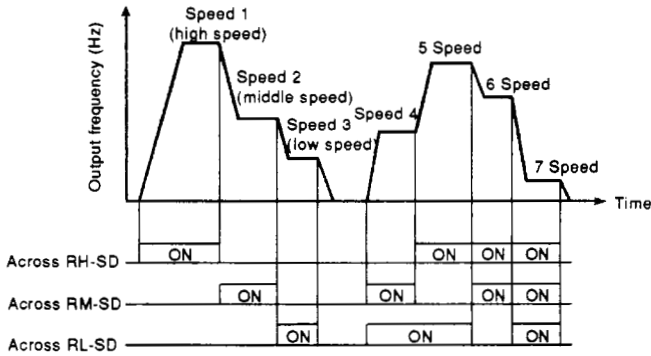

- Note: 1. Speeds 4 to 7 are not selected if the setting is 9999 (factory setting).
 2. These speeds have priority over the main speed (across terminals 2-5, 4-5).
 3. This setting may also be made during PU operation or external operation.
 4. With 3-speed setting, if two or three speeds are simultaneously selected, priority is given to the frequency of lower signal.

Pr. 7 Pr. 8 Setting of acceleration and deceleration times

Pr. 7 Acceleration time **Pr. 20** Acceleration/deceleration reference frequency
Pr. 8 Deceleration time **Pr. 21** Acceleration/deceleration time increment

- In acceleration time Pr. 7, set a period of time required to reach the reference frequency Pr. 20 from 0Hz. In deceleration time Pr. 8, set a period of time required to reach 0Hz from Pr. 20.
- In acceleration/deceleration time increment Pr. 21, the setting range and minimum setting increment can be specified.

Set value 0: 0 to 3600 seconds
 (minimum setting increment 0.1 seconds)

Set value 1: 0 to 360 seconds
 (minimum setting increment 0.01 seconds)

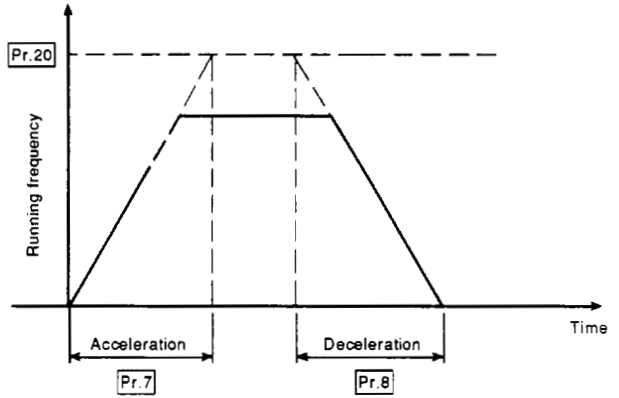

- Note: In only S-pattern acceleration/deceleration A (see Pr. 29), the set time is a period of time required to reach the base frequency (Pr. 3).
 If Pr. 20 (acceleration/deceleration reference frequency) setting is changed, the set values of calibration Pr. 903 and Pr. 905 (frequency setting signal gain) remain unchanged. To adjust the gains, adjust calibration Pr. 903 and Pr. 905.

Pr. 9 Setting of electronic overcurrent protection

- The set value for motor overheat protection may be set as a current value (A). Normally set the rated current value of the motor at 50Hz. This function provides an optimum protective characteristic including a reduction in motor cooling capability in low-speed operation.
- Setting of 0A makes the motor protective function invalid. (The inverter output transistor protective function is valid.)
- When Mitsubishi's constant-torque motor is used, set 1 in Pr. 71 (applied motor) to select the 100% continuous torque (thermal) characteristic in the low speed range, and set the rated motor current in Pr. 9 (electronic overcurrent protection).
- Factory setting (rated output current of the inverter)
 Note that the 0.4K and 0.75K are factory-set to 85% of the rated inverter current (A).

Pr. 10 Pr. 11 Pr. 12 Adjustment of DC dynamic brake

Pr. 10 DC dynamic brake operation frequency
Pr. 11 DC dynamic brake operation time
Pr. 12 DC dynamic brake voltage

- Setting the stopping DC dynamic brake torque (voltage), operation time and operation starting frequency (*) allows the stopping accuracy of positioning operation, etc. to be adjusted according to the load.

Pr. 12-Pr.16

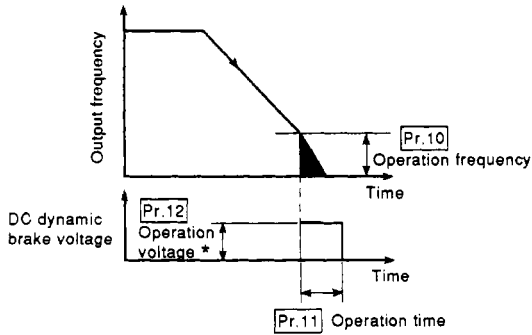

- * 1. Factory setting (DC dynamic brake voltage) 7.5K and down...6%, 11K and up...3%
- * 2. Setting 9999 in Pr. 10 allows the DC brake to start at the Pr. 13 setting value (starting frequency).

Pr. 13 Setting of starting frequency

- Allows the starting frequency to be set between 0 and 60Hz.

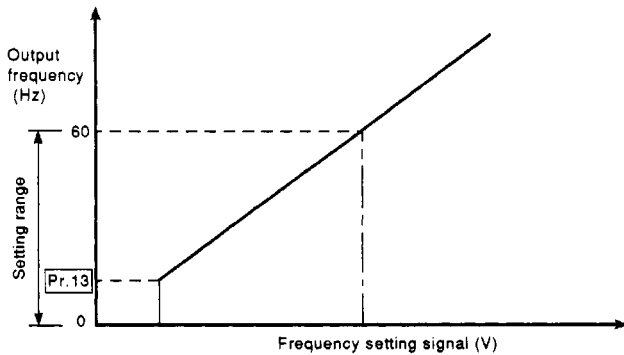

Pr. 14 Selection of applied load

- Allows the optimum output characteristic (V/F characteristic) to be selected for application and load characteristic.

Set value 0 (factory setting)
For constant-torque loads
(e.g. conveyor, carrier)

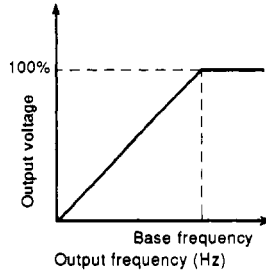

Set value 1
For variable-torque loads
(e.g. fan, pump)

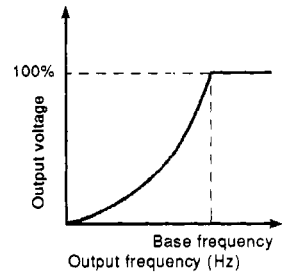

Set value 2

For lift
Boost for forward rotation
..... Pr. 0 set value
Boost for reverse rotation
..... 0%

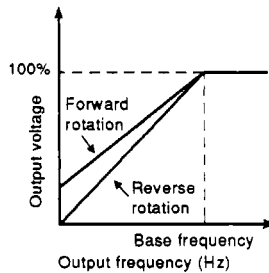

Set value 3

For lift
Boost for forward rotation
..... 0%
Boost for reverse rotation
..... Pr. 0 set value

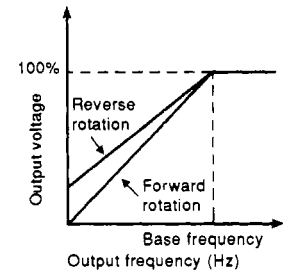

Note: This parameter need not be set when the magnetic flux vector control mode has been selected in Pr. 80 and Pr. 81.

Pr. 15 Pr. 16 Setting for jog operation

Pr. 15 Jog frequency **Pr. 16** jog acceleration/ deceleration time

- Allows jog operation to be started and stopped by selecting the jog mode (connecting the JOG and SD terminals) and turning on/off the start signal (terminals STF, STR).
- Jog operation may also be performed by using the parameter unit.

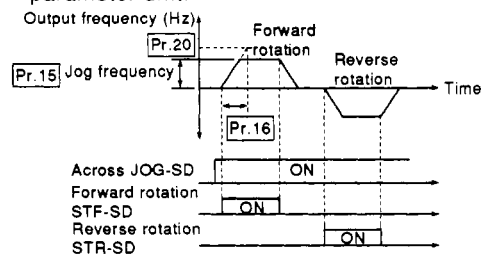

Pr.17-Pr.23

Pr. 17 Selection of external thermal relay input

- The set values 0 and 1 are used to change the function of the JOG/OH input terminal. JOG is used to input the jog operation start signal. OH is used to input the signal contact of a thermal relay installed in the inverter outside or that of a temperature sensor built in the motor.
- The set values 2 and 3 are used to change the function of the MRS terminal to N/C contact input specification (normally closed input).

Pr. 17 Set Value	JOG/OH Terminal Function		MRS Terminal Function	
	Jog mode	OH (external thermal relay input)	N/O Input	N/C Input
0	○		○	
1		○	○	
2	○			○
3		○		○

Set value 0

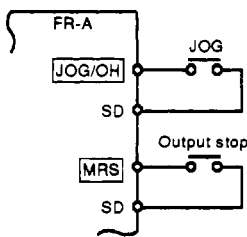

Set value 1

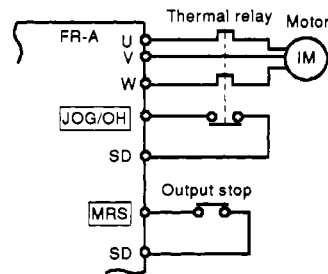

Set value 2

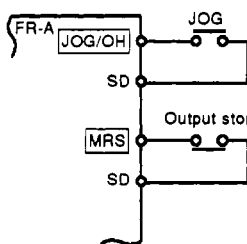

Set value 3

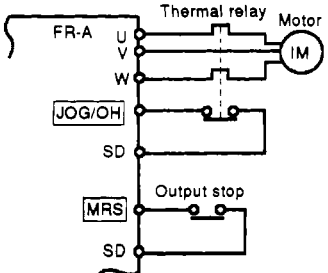

Pr. 18 Setting of high-speed maximum frequency

- Set when operation is performed at or over 120Hz.
- Setting this parameter automatically changes the maximum frequency Pr. 1 to this set value.

Pr. 19 See the section of Pr. 3.

Pr. 20 Pr. 21 See the section of Pr. 7.

Pr. 22 Pr. 23 Pr. 66 Setting of current limit operation level

- Pr. 22 Stall prevention operation level (current limit operation level)
- Pr. 23 Stall prevention operation level at double speed (current limit level reduction ratio at 400Hz)
- Pr. 66 Stall prevention operation level reduction starting frequency

- In Pr. 22, set the stall prevention operation level (current limit level). Normally set to 150% (factory setting). Pr. 22 can be changed in set value during operation.
- When operation is performed at high speed at or over 60Hz, the current limit level in the high-frequency range can be reduced to protect the motor. Pr. 66 is for the reduction starting frequency and Pr. 23 for the reduction ratio. Normally set 60Hz in Pr. 66 and 100% in Pr. 23.
- When 9999 (factory setting) is set in Pr. 23, the current limit level is kept constant at the Pr. 22 value up to 400Hz.

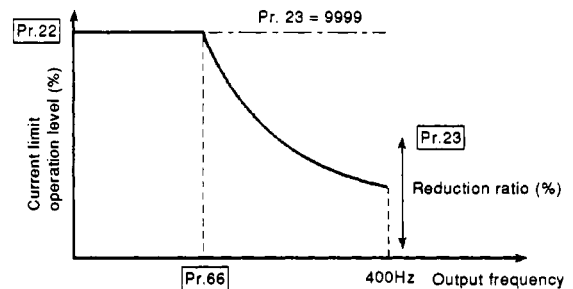

Setting example (Pr. 22 = 150%, Pr. 23 = 100%, Pr. 66 = 60Hz)

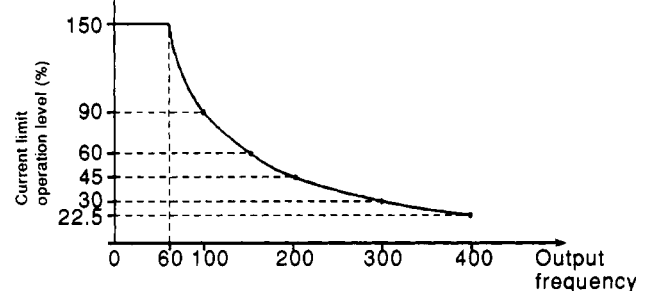

- Current limit operation level calculating method

$$\text{Current limit operation level (\%)} = A + B \times \left(\frac{\text{Pr.22} - A}{\text{Pr.22} - B} \right) \times \left(\frac{\text{Pr.23} - 100}{100} \right)$$

where,

$$A = \frac{\text{Pr.66(Hz)} \times \text{Pr.22(\%)}}{\text{Output frequency(Hz)}}, B = \frac{\text{Pr.66(Hz)} \times \text{Pr.22(\%)}}{400(\text{Hz})}$$

Pr.24-Pr.30

Pr. 24 **Pr. 25** **Pr. 26** **Pr. 27** See the section of **Pr. 4**

Pr. 28 Selection of multi-speed input compensation

Allows the speeds (frequencies) of multi-speed settings selected by the RH, RM and RL terminals to be compensated for by entering a compensation signal into the auxiliary input terminal 1.

Set Value	Compensation by Auxiliary Input
0	No compensation (factory setting)
1	Compensation available

Pr. 29 Selection of acceleration/deceleration pattern

Allows selection of the appropriate acceleration/deceleration pattern for application.

- Set value 0 (linear acceleration/deceleration) provides a general acceleration/deceleration pattern for ordinary use.
- Set value 1 (S-pattern acceleration/deceleration A) is used when it is necessary to make acceleration/deceleration in a short time up to the 60Hz or higher speed range. In this acceleration/deceleration pattern, fb (base frequency) is always the inflection point of an S shape, allowing acceleration/deceleration time to be set according to the reduction in motor torque in the 60Hz or higher constant-output operation range. This pattern is appropriate for applications such as machine tool spindles.
- Set value 2 (S-pattern acceleration/deceleration B) provides an S-pattern acceleration/deceleration from f2 (current frequency) to f1 (target frequency), easing acceleration/deceleration shock. This pattern has an effect on the prevention of cargo collapse.

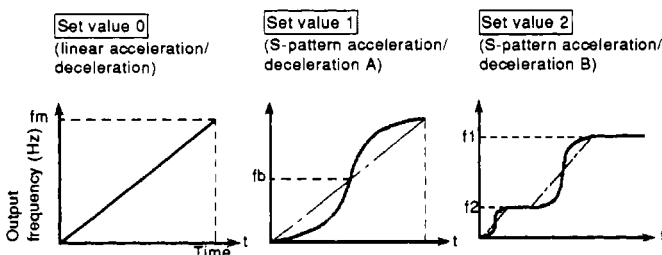

- Set value 3 enables the backlash compensation function. This function stops the output frequency change temporarily during acceleration/deceleration, reducing shock (backlash) generated when a reduction gear backlash is eliminated suddenly. Pr. 33 to Pr. 36 are used for setting of the backlash compensation parameters.

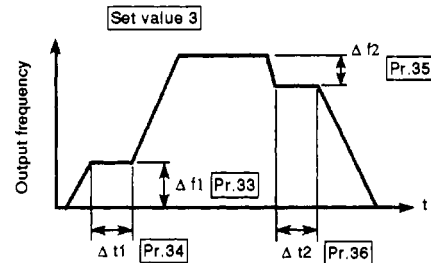

Pr. Number	Function	Setting Range	Factory Setting
33	Backlash acceleration stopping frequency	0 to 400Hz	1Hz (9999)
34	Backlash acceleration stopping time	0 to 360 seconds	0.5 seconds (9999)
35	Backlash deceleration stopping frequency	0 to 400Hz	1Hz (9999)
36	Backlash deceleration stopping time	0 to 360 seconds	0.5 seconds (9999)

Note: Pr. 31 and 32 are implemented as frequency jump functions.

Pr. 30 **Pr. 70** Setting of regenerative brake operation duty

- Pr. 30** Regenerative brake operation duty change selection
- Pr. 70** Special regenerative brake operation duty

- Set when it is necessary to increase the regenerative brake operation duty for frequent start/stop operations. In this case, as a higher brake resistor capacity is required, use the optional FR-ABR high-duty brake resistor.
- Setting method: After setting 1 in Pr. 30 (operation duty change selection), set the operation duty in Pr. 70.

Model	Pr. 70 Factory Setting
FR-A220-0.4K to 3.7K	3% (note 3)
FR-A220-5.5K, 7.5K	2%
FR-A240-0.4K to 7.5K	2%

Pr.30-Pr.39

- Note: 1. When the Pr. 70 setting is increased from the factory setting, the set value must be matched to the permissible brake operation duty of the external brake resistor.
2. Setting is invalid for the 11K and higher capacity models.
3. The brake operation duty indicates %ED of the built-in brake transistor operation.
4. When Pr. 30 is 0, Pr. 70 is not displayed.

- Set the number of motor poles or the machine speed at 60Hz operation.
- This setting is valid only when running speed display has been selected for the inverter LED display or PU main monitor. (See Pr. 51 and Pr. 52.)

Pr. 37 Set Value	Running Speed Display
2 to 10	Set value is the number of motor poles. Display value is the motor speed. Example: At the set value of 2, 3600 (r/min) is displayed when 60Hz is output.
11 to 9998	Set the machine speed at 60Hz operation. Example: At the set value of 150 (m/min), 150 (without display unit) is displayed when 60Hz is output.

Pr. 31 Pr. 32 Pr. 33
Pr. 34 Pr. 35 Pr. 36 frequency jump

- Allows a mechanical resonant point to be jumped. Up to three areas may be set, with the jump frequency set to either the top or bottom point of each area.
- The value set to 1A, 2A or 3A is a jump point and operation is performed at this frequency.

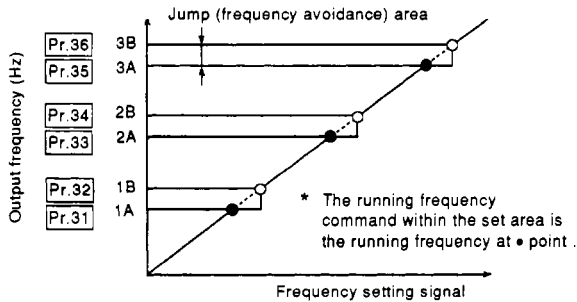

- Note: 1. Only the display unit is set in this parameter. For the other frequency-related parameters (such as Pr. 1), set a frequency unit.
2. In the V/F control mode, the motor speed is converted into the output frequency and does not match the actual speed. When the magnetic flux vector control mode has been selected in Pr. 80 and 81, this display shows the actual speed (estimated value resulting from the compensation of motor slippage).
3. The factory set value is 4 (1800r/min is displayed when 60Hz is output).

- Note: 1. Frequency jump is not made when the set value is 9999 (factory setting).
2. Setting 3 in Pr. 29 switches Pr. 33-36 into the backlash compensation setting functions. But Pr. 33 to 36 setting ranges are not displayed on the PU screen. And frequency jump parameter setting values are displayed in the parameter change list and initial value list, that is, when Pr. 29 is set to 3, Pr. 33 to 36 setting values are not displayed in the lists.
3. During acceleration/deceleration, the running frequency within the set area is valid.

Pr. 38 Pr. 39 Setting of automatic torque boost

- Pr. 38** Automatic torque boost
Pr. 39 Automatic torque boost starting current

- Automatically controls the inverter output voltage (torque) according to the load current detected.

Pr. 37 Setting of speed display unit

- Allows the machine running speed, e.g conveyor speed, to be indicated as a machine speed value. The running speed display unit of the inverter LED display and PU main monitor can be set according to the speed specifications of the relevant machine.

Function Number	Set Value
38	Boost compensation value (%) 0: automatic torque boost disable (factory setting) Normally set 100% to operate the automatic torque boost.
39	Automatic torque boost starting current (A) (Normally set 0A.)

Pr.39-Pr.43

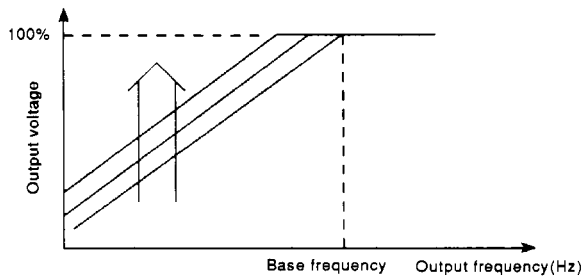

Note: The automatic torque boost need not be set when the magnetic flux vector control mode has been selected in Pr. 80 and 81.

Pr. 40 Setting of output terminal assignment

- Any of 10 functions can be reassigned to the SU, IPF, OL and FU output terminals individually. Set a 4-digit integer in Pr. 40. (0 in the 1st digit is not displayed.)

Pr. 40: 1st digit 2nd digit 3rd digit 4th digit

(factory setting: 1 2 3 4)

Terminals: SU IPF OL FU

Example: When the Pr. 40 set value is 3249.

Terminal SU: OL (overload alarm) signal

Terminal IPF: IPF/UVT (instantaneous power failure/undervoltage alarm) signal

Terminal OL: FU1 (frequency detection) signal

Terminal FU: PU (PU operation) signal

Set Value	Function Code	Function Name	Operation	Related Pr.
0	RUN	Inverter running	Output when the inverter is running at or over the starting frequency.	-
1	SU	Up-to-frequency	Output when the output frequency has reached the set frequency.	Pr. 41
2	IPF/UVT	Instantaneous power failure or undervoltage	Output when instantaneous power failure or undervoltage occurs.	
3	OL	Overload alarm	Output while the current limit function is operating.	Pr. 22, 23
4	FU1	Frequency detection	Output at or over the specified detection frequency.	Pr. 42, 43
5	FU2	Second frequency detection	Output at or over the specified detection frequency.	Pr. 50
6	RBP	Regenerative brake pre-alarm	Prealarm is output on reaching 85% of the regenerative brake operation factor set in Pr. 70	Pr. 70
7	THP	Electronic overcurrent protection alarm	Output when the electronic overcurrent protection cumulative value reaches 85% of the set level.	Pr. 9
9	PU	PU operation mode	Output when the PU operation mode is selected.	-

Note: The function of the RUN terminal (output during inverter running) is fixed. This function cannot be changed by using Pr. 40.

Note: Output indicates that the built-in transistor for open collector output is turned on (conducts).

Pr. 41 Adjustment of up-to-frequency sensitivity

- Allows the output signal ON range to be adjusted between 1 and 100% of the running frequency when the output frequency reaches the running frequency.

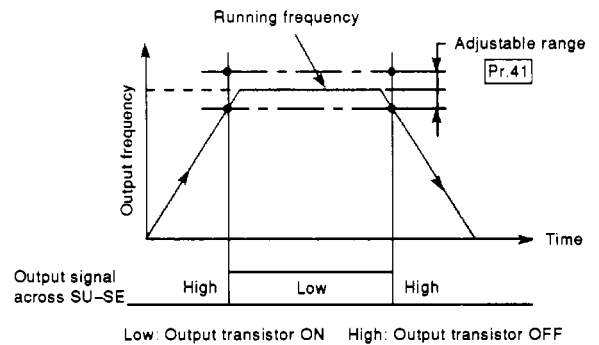

Low: Output transistor ON High: Output transistor OFF

Pr. 42 **Pr. 43** Setting of output frequency detection

Pr. 42 Output frequency detection

Pr. 43 Output frequency detection at reverse rotation

- The signal across terminals FU-SE is switched low when the output frequency reaches or exceeds the selected detection frequency (value set in output frequency detection Pr. 42), and is switched high when it drops below the detection frequency. This function can be used for electromagnetic brake operation, open signal, etc.

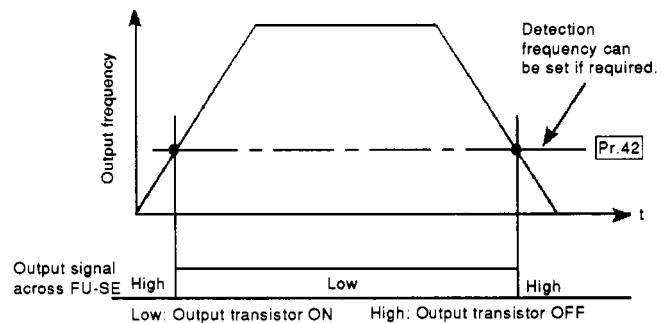

Low: Output transistor ON High: Output transistor OFF

Pr.43-Pr.54

- Setting a value in Pr. 43 allows the frequency to be detected exclusively for the reverse rotation. (In this case, the set value in Pr. 42 is for the forward operation only.) This function is effective for switching the timing of electromagnetic brake operation between forward rotation (rise) and reverse rotation (fall) during elevating operation, etc. This parameter is factory-set to 9999. In this state, the detection frequency is the Pr. 42 set value for both the forward rotation and reverse rotation.

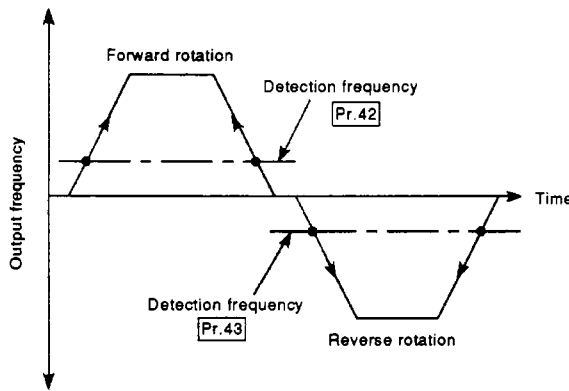

Pr. 44 Pr. 45
Pr. 46 Pr. 47 Setting of second control functions

- Pr. 44** Second acceleration/deceleration time
- Pr. 45** Second deceleration time
- Pr. 46** Second torque boost (manual)
- Pr. 47** Second V/F (base frequency)

- The external contact signal (across terminals RT-SD) allows the acceleration and deceleration times, boost setting, etc. to be changed together.
- Effective for switching between two motors different in parameter setting, e.g. elevating and traversing.

Set Function	Parameter number	Signal across Terminals RT-SD	
		OFF	ON
Acceleration time	Pr. 7	○	
	Pr. 44		○
Deceleration time	Pr. 8	○	
	Pr. 45		○
Torque boost (manual)	Pr. 0	○	
	Pr. 46		○
Base frequency	Pr. 3	○	
	Pr. 47		○

Note: Setting 9999 (factory setting) in Pr. 45 causes both the acceleration and deceleration times to be the value set in Pr. 44.

Note: Pr. 46 need not be set when the magnetic flux vector control mode has been selected in Pr. 80 and Pr. 81.

Note: The 2nd acc./dec. time is the time taken for acceleration to the frequency set in Pr. 20, as well as Pr. 7 and Pr. 8.

Pr. 48 Pr. 49 Setting of second stall prevention operation level

- Pr. 48** Second stall prevention (current limit) operation level (current setting)
- Pr. 49** Second stall prevention (current limit) operation frequency
- Allows the stall prevention (current limit) operation level to be changed within the range from 0Hz to the frequency set in Pr. 49. Effective for a stop on contact, which requires low torque at low speed.
- This function is not valid during acceleration and is only valid during deceleration or at constant speed.
- This function is invalid when 0 is set in Pr. 49 (factory setting).

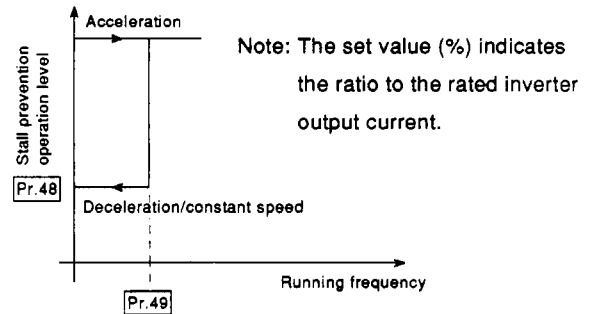

Pr. 50 Setting of second output frequency detection

- In addition to the detected output frequencies set in Pr. 42 and Pr. 43, the detected output frequency can be set.
- By setting 5 (FU2) in any of the first to fourth digits of Pr. 40, the signal can be output from any of the SU, IPF, OL and FU terminals. The terminal signal is turned on at or above the set frequency (the built-in transistor is switched on). (See the section of Pr. 42 and Pr. 43.)

Pr. 51 Pr. 52
Pr. 53 Pr. 54 Selection of monitor and output signals

- Pr. 51** Inverter LED display data selection
- Pr. 52** PU main display data selection
- Pr. 53** PU level display data selection
- Pr. 54** FM terminal function selection

Pr.54-Pr.56

- By setting any of the numbers in the following table, the required signal can be selected from among the 21 signals for the monitor and signal output.
- There are two types of signal outputs: FM pulse train output terminal and AM analog output terminal. Select either terminal by setting a corresponding value in the Pr. 54. The output is turned off at stop or during trip occurrence.
- Factory setting:
Pr. 51.....1
Pr. 52.....0
Pr. 53.....1
Pr. 54.....1

Signal Type	Display Unit	Parameter Set Value					Full-Scale Value of FM, AM, Level Meter
		Pr.51	Pr.52	Pr.53	Pr.54		
		Inverter LED	PU main monitor	PU level meter	FM term inal	AM term inal	
No display	—	X	X	0	X	X	—
Output frequency	Hz	1	0	1	1	101	Pr.55
Output current	A	2	0	2	2	102	Pr.56
Output voltage	V	3	0	3	3	103	400V or 800V
Alarm display	—	4	0	X	X	X	—
Frequency set value	Hz	5	X *	5	5	105	Pr.55
Running speed	(r/min)	6	X *	6	6	106	Value converted from Pr. 55 by Pr. 37 value
Motor torque **	%	7	X *	7	7	107	Rated torque of applied motorX2
Converter output voltage	V	8	X *	8	8	108	400 or 800
Regenerative brake duty	%	9	X *	9	9	109	Pr.70
Electronic overcurrent protection load factor	%	10	X *	10	10	110	Protector operation level
Output current peak value	A	11	X *	11	11	111	Pr.56
Converter output voltage peak value	V	12	X *	12	12	112	400V or 800V
Inverter input power	kW	13	X *	13	13	113	Rated power of applied motor x 2
Inverter output power	kW	14	X *	14	14	114	Rated power of applied motor x 2
Input terminal status	—	X	X *	X	X	X	—
Output terminal status	—	X	X *	X	X	X	—
Load meter	%	17	17	17	17	117	Pr.56
Motor exciting current	A	18	18	18	18	118	Pr.56
Cumulative operation time	hr	X	20	X	X	X	—
Reference voltage output	—	X	X	X	21	121	1440Hz is output to FM terminal. Full-scale voltage is output to AM terminal.

Note: Monitor cannot be selected for items marked x.

- Note: Setting 0 in Pr. 52 (PU main monitor) allows the monitoring of output frequency to alarm display to be selected in sequence by the shift key. (Factory setting)
- Frequency set value to output terminal status on the PU main monitor are selected by "other monitor selection" of PU operation.

** Motor torque display is valid only when in the magnetic flux vector control mode.

Note: When any of the signals marked * has been selected in Pr. 54 (FM terminal function selection), the outputs of the FM and AM terminals are zero while the inverter is at stop or alarm.

Note: Setting 1, 2, 5, 6, 11, 17 or 18 in Pr. 53 or Pr. 54 allows the full scale value to be set in Pr. 55 or Pr. 56.

Pr. 55 Pr. 56 Setting of monitoring reference

Pr. 55 Frequency monitoring reference

Pr. 56 Current monitoring reference

- Set the frequency or current value which is referenced for display when the frequency or current is selected for the FM and AM terminals and PU level meter display.

Monitoring Reference Setting Pr	Monitor Screen Selection	Pr. 53 Setting	FM, AM Terminal Function Selection Pr. 54 Setting	
f monitoring reference Pr. 55	Output f (Hz)	1	1	101
	f setting (Hz)	5	5	105
	Running speed (Pr. 37)	6	6	106
I monitoring reference Pr. 56	Output I (A)	2	2	102
	Peak I (A)	11	11	111
	Load meter (%)	17	17	117
	Motor excitation I (A)	18	18	118
Setting method using Pr. 55, Pr. 56		PU level meter indication is full-scale.	Terminal FM output is 1440Hz.	Terminal AM output is 10V.

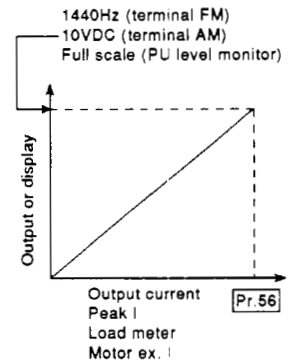
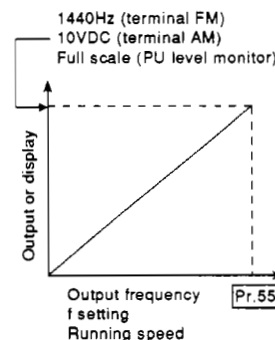

- Note: 1. FM maximum output f is 2400Hz.
- 2. AM maximum output voltage is 10VDC.

Pr.57-Pr.59

Pr.57 Pr.58 Automatic restart operation after instantaneous power failure/commercial power supply-inverter switch-over

- Pr. 57** Coasting time (reset time) for automatic restart after instantaneous power failure/commercial power supply-inverter switch-over
- Pr. 58** Rise time for automatic restart after instantaneous power failure/commercial power supply-inverter switch-over

- Allows the inverter to be restarted without stopping the motor (with the motor coasting) when the commercial power supply is switched to the inverter operation or when power is restored after instantaneous power failure.
- Pr. 57 (coasting time)

Set Value	Automatic Restart Operation Enable/Disable
9999 (factory setting)	Disable
0, 0.1 to 5	Enable

Coasting time indicates a waiting time for automatic restart after power restoration.

- Setting 0 in Pr. 57 sets the coasting time to the following standard time. Most applications can be satisfied with this setting. This time may also be adjusted between 0.1 and 5 seconds according to the magnitude of load inertia (GD^2) and torque.

Too short time for setting, automatic restart function may not be operated.

- 0.4K to 1.5K ... 0.5 seconds
- 2.2K to 7.5K ... 1.0 seconds
- 11K and up 3.0 seconds

- Pr. 58 (rise time) setting
Normally operation is satisfactory with this parameter remaining at the factory setting of 1.0 seconds. The output voltage rise time for restart control may also be adjusted between 0.1 and 5 seconds according to the magnitude of load specifications (inertia, torque).

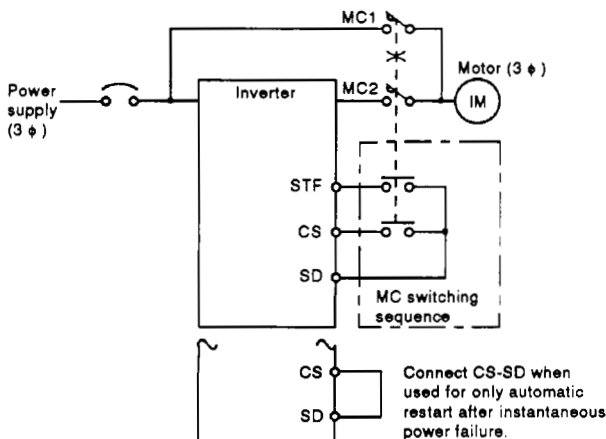

Pr. 59 Selection of remote setting function

- By setting 1 or 2 in Pr. 59, the functions of the RH and RM terminals can be changed to the remote setting input functions.
- Merely setting this parameter provides functions identical to those of the FR series FR-FK motorized speed setter (option).

Pr. 59 Set Value	Operation	
	Remote setting function	Frequency set value storage function (*)
0	X	-
1	O	O
2	O	X

O: yes, X: no

- (*) After RH-SD and RM-SD are kept open for more than about one minute, the running frequency set value is stored into the memory. When the power is switched off, then on, operation is resumed at this set value.

Connection

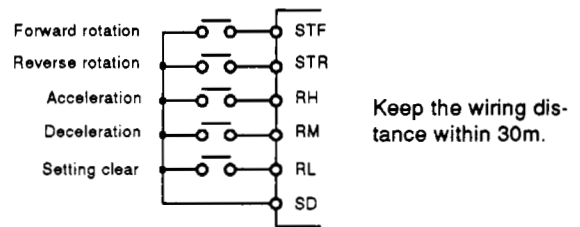

Operation Example

Note: Acceleration and deceleration times are Pr. 7 and Pr. 8 set values.

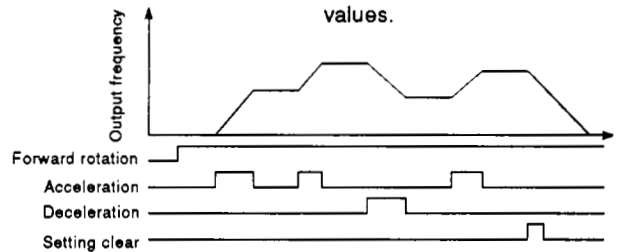

Note: The f setting value up/down times are set in Pr. 44 and Pr. 45, but the output f acc./dec. times in Pr. 7 and Pr. 8. Therefore, the actual acc./dec. times become the longer setting values respectively.

Pr.60

Pr. 60 Intelligent mode selection

- By selecting this parameter, the inverter is automatically adjusted as if the appropriate value had been set in each parameter, without needing to set the acceleration and deceleration times and V/F pattern. This operation mode is useful when it is desired to perform operation immediately without making fine parameter settings. The inverter automatically selects appropriate parameters.

(Note 1)

Pr. 60 Set Value	Set Function	Operation	Automatically Set Parameters
0 (factory setting)	Ordinary operation mode	—	—
1 2	Shortest acceleration/ deceleration mode	Set when it is desired to accelerate/decelerate the motor in the shortest time. The inverter makes acceleration/deceleration in the shortest time using its full capabilities. During deceleration, an insufficient braking capability may cause the overvoltage alarm (E.OV3). Set value 1: current limit value 150% Set value 2: current limit value 180%	Pr. 7 Pr. 8
3	Optimum acceleration/ deceleration mode	Self-learning system automatically sets the boost value, acceleration and deceleration times so that the current during acceleration/deceleration is lower than the rated current of the inverter. Optimum operation can be carried out by fully utilizing the inverter capabilities in the rated continuous range. Appropriate for application where the load will not vary largely. (Note 2)	Pr. 0 Pr. 7 Pr. 8
4	Energy-saving mode	Tunes the inverter output voltage online so that the inverter output voltage is minimized during constant-speed operation. Appropriate for energy-saving application such as fan and pump.	Output voltage
5 6	Elevator mode	Automatically controls the inverter output voltage so that the maximum torque can be delivered in the driving and regenerative modes. Also automatically selects the acceleration/deceleration pattern in which shock is minimized. Set value 5: current limit value 150% Set value 6: current limit value 180%	Pr. 0 Pr. 13 Pr. 19

- Note: 1. When more accurate control for application is required, set parameters manually.
- Because of the learning system, this control is not valid the first time.
 - When the magnetic flux vector control has been selected using Pr. 80 and Pr. 81, the energy-saving mode and elevator mode need not be set.
 - If intelligent operation is performed using a motor having a larger capacity than the inverter capacity, overcurrent alarm may occur.
 - If an overvoltage (OV3) trip has occurred during operation in the optimum acceleration/deceleration mode, re-set Pr. 8 (deceleration time) to a slightly larger value and restart operation in this mode.
 - When any of 1 to 6 has been set in Pr. 60, the parameters dedicated to intelligent mode Pr. 61 to 64 are valid. Pr. 61 to 64, which need not be set unless required, may be set to improve performance. Set 0 in Pr. 60 to automatically set Pr. 61 - 64 to 9999 (factory setting).

Pr.66-Pr.73

Pr. 66 See the section of **Pr. 22**

Pr. 67 **Pr. 68** **Pr. 69** **Pr. 114** **Retry functions**

Pr. 67 Number of retries at trip occurrence

Pr. 68 Retry waiting time

Pr. 69 Retry count display erasure

Pr. 114 Retry selection

- Retry is a function which causes the inverter to automatically reset a trip at its occurrence, make a restart and continue operation.
- In Pr. 67, set the number of retries at trip occurrence.

Pr. 67 Set Value	Number of Retries
0	Retry is not made.
1 to 10	1 to 10 times

- In Pr. 68, set waiting time from when an inverter trip occurs until a restart is made. When 9999 is set (factory setting), the inverter does not execute retry.
- By reading Pr. 69, the cumulative number of restart times made by retry is provided. The set value of 0 erases the cumulative number of times.
- Use Pr. 114 to select the fault conditions under which automatic restart of the motor will occur.

Pr. 114 Set Value	Operation
0 (factory setting)	retry after all alarms
1	retry after OCT only
2	retry after OVT only
3	retry after OCT and OVT only
4	retry after alarms below OCT, OVT, IPF, UVT, BE, GF, OLT, PE

Note: 1. Since the inverter automatically starts operation after the retry waiting time set in Pr. 68 has elapsed, this function must be used with care so as not to jeopardize the operator.

2. The cumulative number in Pr. 69 is incremented by 1 when retry operation is regarded as successful, i.e. when normal operation is continued without any alarm occurring during a period five times longer than the time set in Pr. 68 (retry waiting time).

3. When the inverter trip is reset at the restart time, the data of electronic overcurrent protector, regenerative brake operation factor, etc. is not reset. (This differs from the power-on reset.)

Pr. 70 See the section of **Pr. 30**

Pr. 71 **Applied motor selection**

- When the Mitsubishi constant-torque motor is used, set 1 in Pr. 71. The electronic overcurrent protection is set to the thermal characteristic of the constant-torque motor.

Pr. 71 Set Value	Characteristic of Electronic Overcurrent Protector
0	For a general-purpose motor
1	For Mitsubishi constant-torque motor
2	For a general-purpose motor 5-point flexible v/f characteristic (Note)

Note: For the adjustment of the 5-point flexible v/f characteristic, refer to p. 72.

When 9999 has been set in Pr. 19, 2 cannot be set in Pr. 71, so set the appropriate value in Pr. 19. (base frequency voltage)

When 2 has been set in Pr. 71, the setting ranges of Pr. 100 to Pr. 109 are not displayed on the PU screen. At this time, if the set value of any of Pr. 100 to Pr. 109 is changed, the new set value is not displayed in the "INITIAL VALUE LIST" and "CHANGE LIST".

Pr. 72 **Changing of PWM carrier frequency**

- The FR-A series PWM carrier frequency of 14.5kHz can be changed by using Pr. 72 when trying to reduce the effects of motor/mechanical system resonance.

Pr. 73 **Frequency command voltage range selection**

- Set the input specifications of terminals 1, 2 and 4 and the presence/absence of the override function.

Pr.73-Pr.76

Pr. 73 Set Value	Terminal AU Signal	Terminal 2 Input Voltage	Terminal 1 Input Voltage * 1	Terminal 4 Input, 4 to 20mA	Override Function * 2	Polarity Reversibility		
0	No	0 to 10V *	0 to ± 10V	X	X	* 3		
		0 to 5V *						
2		0 to 10V *	0 to ± 5V					
3		0 to 5V *						
4		0 to 10V	0 to ± 10V *					
5		0 to 5V	0 to ± 5V *					
10		0 to 10V *	0 to ± 10V					
11		0 to 5V *						
12		0 to 10V	0 to ± 5V					
13		0 to 5V *	0 to ± 10V *					
14		0 to 10V						
15		0 to 5V						
0		Yes	X		0 to ± 10V	O *	X	* 3
1					0 to ± 5V			
2			0 to 10V		X			
3	0 to 5V							
4	X		0 to ± 10V					
5				0 to 5V				
10	X		0 to ± 10V					
11				0 to ± 5V				
12	0 to 10V		X					
13				0 to 5V				
14				0 to 10V				
15	0 to 5V							

- * 1:Terminal 1 (frequency setting auxiliary input) is added to the main speed setting signal of terminal 2 or 4.
- * 2:When override has been selected, terminal 1 or 4 is the main speed setting and 2 is the override signal (50 to 150% at 0 to 5V or 0 to 10V).
- * 3:Indicates that a negative-polarity frequency command signal is not accepted.

Note: 1. x indicates that a signal is not accepted.

- To change the maximum output frequency when the maximum frequency command voltage (current) has been input, use the frequency setting voltage (current) gain, Pr. 903 (Pr. 905).
At this time, the command voltage (current) need not be input.
Also, the acceleration/deceleration time, which is an inclination up to the acceleration/deceleration reference frequency, is not affected by the change of Pr. 73 setting.
- The set value hatched is the factory setting.
The * indicates the main speed setting.

Pr. 74 Input filter time constant

- Allows setting of the built-in filter time constant in the external voltage or current frequency setting signal input section. Effective for eliminating noise in the frequency setting circuit.
- Increase the filter time constant if stable operation cannot be performed due to noise. A larger set value results in lower response.

Pr. 75 Reset selection/PU disconnection detection

- Allows the reset (terminal RES) function to be selected.

Set value	Reset input availability	Operation when disconnected
Set value 0	Reset input is always available (factory setting) *	Operation will be continued with the PU disconnected.
Set value 1	Reset input is available only when protective function is activated.	
Set value 2	Reset input is always available.	When the PU is disconnected, an error is displayed and the inverter output is shut off. (Note)
Set value 3	Reset input is available only when protective function is activated.	

* By short-circuiting across terminals RES-SD during operation, the inverter shuts off output while the signal is on, the data of electronic overcurrent protection and regenerative brake duty is reset, and the motor is coasted to a stop.

Note: For the adjustment of PU disconnection detection, see page 74.

Pr. 76 Alarm code output selection

- When alarm occurs, its code can be output as a 4-bit digital signal from the open collector output terminals.

Set Value	Output Terminal			
	SU	IPF	OL	FU
0 (factory setting)	Depends on the output terminal assignment (Pr. 40).			
1	Alarm code bit 3	Alarm code bit 2	Alarm code bit 1	Alarm code bit 0
2	Normal operation...Operation status signal (same as set value 0) Alarm occurrence...Alarm code signal			

For alarm code, refer to Sec. 8.4.

Pr.77-Pr.81

Pr. 77 Parameter write disable selection

- Prevents functions from being written from the parameter unit.

Set value	Write Disable Function
0	Parameter write enable (at stop only) (factory setting) *
1	Parameter write disable **
2	Parameter write also enabled during operation ***

- * Monitor-related parameters Pr. 51 to Pr. 56 can be set at any time.
- ** Write is allowed for Pr. 77 and Pr. 79 (operation mode selection).
- *** Write is disallowed during inverter operation for Pr. 23, Pr. 48, Pr. 49, Pr. 60, Pr. 66, Pr. 71 and Pr. 79-81.

Pr.78 Reverse rotation prevention selection

- Set to prevent any reverse rotation fault resulting from the mis-input of the start signal.

Set value	Direction of Rotation
0	Both forward and reverse rotations allowed (factory setting)
1	Reverse rotation disallowed
2	Forward rotation disallowed

Note: This function is valid for both the parameter unit and external operations.

Pr. 79 Operation mode selection

- Allows operation to be performed in either or both of the external signal and parameter unit operation modes of the inverter.

Set value 0	Operation can be switched between the parameter unit and external operation modes. (Factory setting)
Set value 1	Operation is only allowed in the parameter unit operation mode.
Set value 2	Operation is only allowed in the external operation mode.
Set value 3 (* 1)	Running frequency...Set from the parameter unit. Start signal.....External signal input.
Set value 4 (* 1)	Running frequency...External signal input Start signal.....Input from the parameter unit.
Set value 6	Switch-over function See page 78.

Note: This function number can also be rewritten in the external operation mode.

The settings of the other parameters cannot be changed. Hence, this function number must be rewritten to change any of the other settings.

- *1. In the parameter unit/external signal combined operation mode, the following signals are made valid:

Set Value	Operation Frequency	Start Signal
3	Parameter unit • Direct setting and . [▲] [▼] key setting • Jog frequency (Pr. 15)	Terminal symbol • STF • STR • JOG/OH
4	Terminal symbol • Across 2-5 0 to 5VDC • Across 2-5 0 to 10VDC • Across 4-5 4 to 20mA • Across 1-5 0 to ± 5VDC 0 to ± 10VDC • Multi-speed selection (Pr. 4 to 6, 24 to 27)	Parameter unit • Forward rotation key • Reverse rotation key • Jog operation

Pr. 80 **Pr. 81** Selection of magnetic flux vector control

Pr. 80 Applied motor capacity

Pr. 81 Applied motor poles

- When the magnetic flux vector control mode is selected, set the capacity and the number of poles (2, 4, 6) of the motor.

When the constant-torque motor is used, set 1 in Pr. 71.

Note 1: When the magnetic flux vector control mode is selected, the following motor conditions apply:

- (1) Mitsubishi general-purpose squirrel-cage motor and Mitsubishi constant-torque motor of which capacity is equivalent to or one rank lower than the inverter capacity. Not applicable to motors less than 0.4kW. (See page 75.)
- (2) The number of motor poles is 2, 4 or 6.
- (3) Single-motor operation (One motor for one inverter)

If any of the above conditions are not met, proper operation characteristics may not be provided.

Note 2: The output frequency does not match the set frequency, and the displayed value fluctuates.

Note 3: In this operation mode, the maximum cable length between the inverter and motor is 30m.

Number of Motor Poles	2 Poles	4 Poles	6 Poles	Remarks
Set value Pr. 81	2	4	6	Magnetic flux vector control
	12	14	16	Magnetic flux vector control. Note that V/F control is selected by connection of terminals RT-SD. At this time, the second acceleration/deceleration time selection is also made valid. (If RT-SD has been connected, control cannot be switched unless the inverter comes to a stop.)

Pr.155-Pr.159

Pr. 155 Terminal RT activated condition selection

- The condition under which RT function is activated can be selected.

Pr. 155 Set Value	Second Control Function Condition
0	Immediately activated and deactivated according to the signal ON/OFF of terminal RT (factory setting).
10	Activated only when the signal of terminal RT is ON at constant speed. (The function is not activated during acceleration/deceleration if the signal of terminal RT is ON.)

Pr. 156 Stall prevention selection

- This parameter selects the following stall prevention modes.
 - Inverter output voltage reduction or not during the stall prevention.
 - The operation conditions under which the stall prevention is activated can be restricted.
 - When the overload alarm (OL) signal is output after the time set in Pr. 157 has elapsed, inverter output shut-off or not can be selected.

For the set values and modes, see the table below.

Pr. 156 Set Value	0	1	2	3	4	5	6	7	8	9	10	11	12	13	14	15	16	17	18	19	20	21	22	23	24	25	26	27	28	29	30	31	100					
Output reduction during stall prevention. 0...reduction selected 1...no reduction	0	1	0	1	0	1	0	1	0	1	0	1	0	1	0	1	0	1	0	1	0	1	0	1	0	1	0	1	0	1	0	1	0	1	Driving	Regenerative		
Stall prevention. 0...available 1...not available	during accel.	0	0	1	1	0	0	1	1	0	0	1	1	0	0	1	1	0	0	1	1	0	0	1	1	0	0	1	1	0	0	1	1	0	1	0	1	
	during const.	0	0	0	0	1	1	1	1	0	0	0	0	1	1	1	1	0	0	0	0	1	1	1	1	0	0	0	0	1	1	1	1	1	0	1	0	1
	during decel.	0	0	0	0	0	0	0	0	1	1	1	1	1	1	1	1	0	0	0	0	0	0	0	0	1	1	1	1	1	1	1	1	1	1	0	1	0
At the OL signal output, 0...operation is kept 1...output shut-off	0	0	0	0	0	0	0	0	0	0	0	0	0	0	0	0	1	1	1	1	1	1	1	1	1	1	1	1	1	1	1	1	1	1	0	0		

- When Pr. 156 is set to shut-off the inverter output at the OL alarm, the alarm code E.OLT is indicated at the inverter stop due to stall prevention.

Pr. 157 OL signal output waiting time

- The overload alarm (OL) signal can be output when the time set in Pr. 157 is exceeded.

Pr. 157 Set Value	Output Signal
0 to 25 seconds 9999	0: output according to overload (OL) (factory setting). 0.1 to 25: output after the set time has elapsed. 9999: overload (OL) alarm signal is not output.

Pr. 159 PWM frequency decrease at low speed

- Speed in the low range (10Hz or less) can be smoothed to correct speed fluctuation. (To be set only when you care about speed fluctuation.)

Set value = 0	Speed fluctuation not corrected, compensation in high range not mode (factory setting).
Set value = 1	Speed fluctuation corrected, compensation in high range not made.
Set value = 2	Speed fluctuation not corrected, compensation in high range made.
Set value = 3	Speed fluctuation corrected, compensation in high range made.

Note: Since the carrier frequency reduces at the set value of 1 or 3, motor noise increases in the low range.

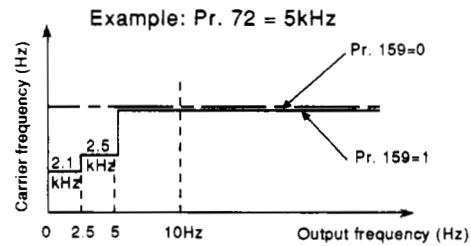

Pr.900-Pr.905

Pr. 900 FM terminal output calibration

- Allows a meter connected to FM to be calibrated from the parameter unit. Common to all monitored data selected in Pr. 54.
- Terminal FM provides the pulse output as shown below. The setting of Pr. 900 allows the meter to be calibrated from the parameter unit without providing a calibration resistor. (For information on the adjusting method, see page 48.)

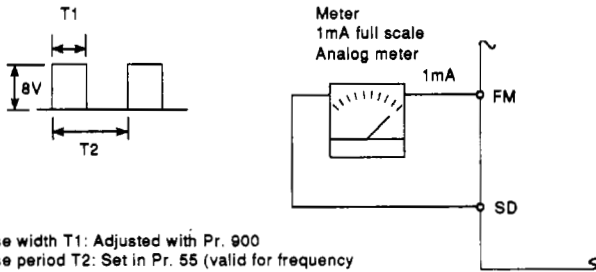

Pulse width T1: Adjusted with Pr. 900
 Pulse period T2: Set in Pr. 55 (valid for frequency monitoring only)

- Monitoring using a digital meter
 Allows a digital value to be displayed on a digital counter using the pulse train signal from the FM terminal. 1440Hz output is provided at the full scale value explained in the section of Pr. 54. When the running frequency has been selected for monitoring, the ratio of this FM output frequency can be set in Pr. 55.

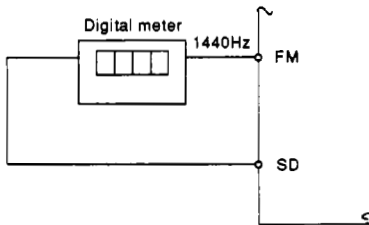

Note: At 60Hz, the parameter is factory-set to 1mA full-scale and 1440Hz FM output frequency.
 The maximum output frequency of FM is 2400Hz.

Pr. 901 AM terminal output calibration

- Calibration parameter used when analog output to terminal AM has been selected by setting any of 101 to 118 in Pr. 54. As explained in the section of Pr. 54, the analog output is factory-set to 10VDC in the full-scale state of each monitored data. This parameter allows the output voltage ratio (gain) to be adjusted according to the meter reading. Note that the maximum output voltage is 10VDC. (For details of the adjustment, see page 49.)

Pr. 902 Pr. 903 Frequency setting signal gain and bias adjustment
Pr. 904 Pr. 905

- Pr. 902 Frequency setting voltage bias
- Pr. 903 Frequency setting voltage gain
- Pr. 904 Frequency setting current bias
- Pr. 905 Frequency setting current gain
- Allows the output frequency to be set in relation to the frequency setting signal (0 to 5V, 0 to 10V or 4 to 20mA DC).

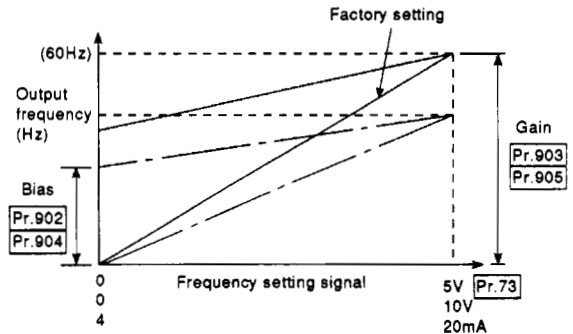

Note: If the gain adjustment (Pr. 903, Pr. 905) is changed, the acceleration/deceleration reference frequency (Pr. 20) does not change.
 The signal to the terminal 1 (aux. input) is added to the frequency setting signal.

5-Point Flexible v/f Characteristic

The V/F characteristic can be changed by linear interpolation made between five points set from V/F1 to V/F5.

■ Operation

An optional V/F characteristic can be set by setting V/F1 (first frequency)(first frequency voltage), V/F2, V/F3, V/F4 and V/F5 from the parameter unit in advance.

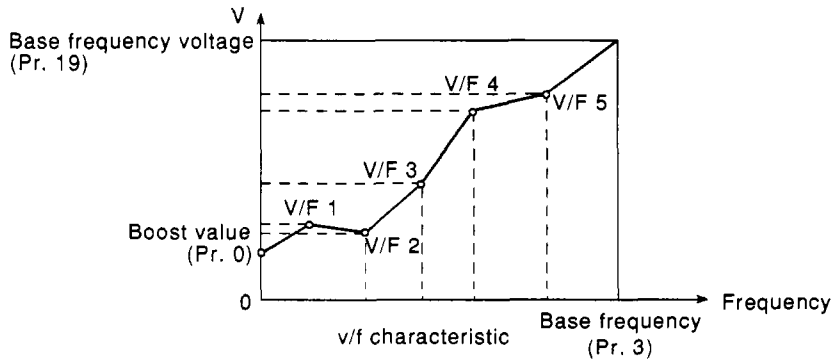

■ Adjustment

- Set 2 in Pr. 71 from the parameter unit. (When Pr. 71 = 0 or 1, the standard V/F characteristic is provided.)
- Set the desired frequencies and voltages in Pr. 100 to Pr. 109.
The setting must satisfy the following relationship: $F1 \neq F2 \neq F3 \neq F4 \neq F5 \neq \text{base frequency}$
If the set frequencies are the same, a write error occurs.
- If "9999" is set in any frequency, it is ignored.

■ Notes

- (1) The V/F 5-point flexible characteristic functions for V/F control only.
- (2) The V/F 5-point flexible characteristic does not function when Pr. 60 (intelligent mode selection) is selected.
- (3) The base frequency voltage may be set optionally between 0 and 1000V, but output voltage is clamped at the base frequency voltage if output frequency is beyond the base frequency.
- (4) Pr. 19 (base frequency voltage) must be set. (When Pr. 19 = 9999, Pr. 71 cannot be set to 2.)
- (5) If "2" is set in Pr. 71, Pr. 47 (second V/F (base frequency)) does not function.
- (6) When "2" is set in Pr. 71, the electronic overcurrent protection is calculated as a general-purpose motor.

5-Point Flexible v/f Characteristic

■ V/F1 to 5 adjustment (setting) range

Parameter No.	Applicable Motor Selection (Pr. 71) ≠ 2		Applicable Motor Selection (Pr. 71) = 2			
	Function Name	Setting range	Function Name	Setting range (Note 2)	Minimum Increments	Factory setting
Pr. 100	BCD input (offset)	0 to 400Hz	V/F1 (first frequency)	0 to 400Hz, 9999	0.01	9999
101	BCD input (gain)	0 to 400Hz, 9999	V/F1 (first frequency voltage)	0 to 1000V	0.1	0
102	Binary input (offset)	0 to 400Hz	V/F2 (second frequency)	0 to 400Hz, 9999	0.01	9999
103	Binary input (gain)	0 to 400Hz, 9999	V/F2 (second frequency voltage)	0 to 1000V	0.1	0
104	BCD/binary selection	0, 1, 2, 3, 9999	V/F3 (third frequency)	0 to 400Hz, 9999	0.01	9999
105	Speed feedback range	0 to 400Hz, 9999	V/F3 (third frequency voltage)	0 to 1000V	0.1	0
106	Feedback gain	0 to 100	V/F4 (fourth frequency)	0 to 400Hz, 9999	0.01	9999
107	Slip compensation selection	0, 10	V/F4 (fourth frequency voltage)	0 to 1000V	0.1	0
108	——	——	V/F5 (fifth frequency)	0 to 400Hz, 9999	0.01	9999
109	——	——	V/F5 (fifth frequency voltage)	0 to 1000V	0.1	0

Note: 1. The set values of Pr. 100 to 109 set when Pr. 71 = 0 or 1 are stored internally and remain unchanged if the set values are written with Pr. 71 = 2.

When the inboard option is added with 2 set in Pr. 71, the parameters set with Pr. 71 = 0 or 1 are made valid and the option operates with these parameters.

2. These setting ranges are not displayed on the PU screen with Pr. 71 = 2.

PU DISCONNECTION DETECTION FUNCTION

This function detects that the parameter unit (PU) has been disconnected from the inverter and brings the inverter to an alarm stop.

■ Operation

When the PU disconnection detection function is selected from the parameter unit, this function detects that the PU has been disconnected from the inverter and brings the inverter to an alarm stop.

Function Number	Function Name	Setting Range	Factory Setting	Description
75	Reset selection	0, 1, 2, 3	0	0 : Reset input normally enabled. PU disconnection is not detected. 1 : Reset input enabled only when protective function is activated. PU disconnection is not detected. 2 : Reset input normally enabled. PU disconnection is detected. 3 : Reset input enabled only when protective function is activated. PU disconnection is detected.

*When the inverter comes to an alarm stop, the alarm messages displayed are PU DISCONNECTED (PU) and E.PUE (inverter LED).

■ Notes

1. Alarm does not occur if the PU has been disconnected from initial start.
2. This disconnection detection function judges that the PU is disconnected when the PU is removed for more than 1 second.
3. When the FR-PU01 is used, this function can also be used but its alarm display is E. PE.
4. To resume operation, reset the inverter after checking that the PU is connected securely.

MAGNETIC FLUX VECTOR CONTROL

Selection of Magnetic Flux Vector Control

Magnetic flux vector control can be selected by setting the capacity, number of poles, and type of the motor used.

(1) Conditions for selecting magnetic flux vector control

Only when the following conditions are met, magnetic flux vector control can be utilized efficiently. When any of the following conditions cannot be satisfied, faults such as torque shortage and speed fluctuation may occur. In this case, select V/F control.

- The motor capacity is equal to or one rank lower than the inverter capacity.
Note that the motor capacity must be 0.4kW or more.
- The type of the motor is the Mitsubishi standard motor or Mitsubishi constant-torque motor or the U.S. Baldor's 400V series inverter-duty motor.
- The number of motor poles is any of 2, 4 and 6.
- Single-motor operation (one motor for one inverter) is performed.
- The wiring length between the inverter and motor is within 30m.

(2) Magnetic flux vector control selection method

Only set any other values than 9999 in Pr. 80 (motor capacity) and Pr. 81 (number of poles) to select the magnetic flux vector control.

When 9999 has been set to either of Pr. 80 and Pr. 81, V/F control is selected.

When the Mitsubishi constant-torque motor is used, set 1 in Pr. 71.

- By switching on/off the signal across terminals RT-SD, operation can be switched between the V/F control and magnetic flux vector control.

(Note) The magnetic flux vector control is available for the U.S. Baldor's 400V series inverter-duty motor when any of 0.75 to 55kw is set in Pr. 80 and 4 is set in Pr. 81 for the A200 US version 400V series inverter.

In the following cases, this function is available only for the Mitsubishi standard motor.

- The 200V series
- For the 400V series inverter, 0.4kw is set in Pr. 80 or 2 or 6 is in Pr. 81.

For motors other than the listed above, please contact your Mitsubishi representative.

(3) Precautions for magnetic flux vector control

- The degree of speed fluctuation correction is slightly lower than in the V/F control.
- There is a delay of 0.1 to 0.2sec at start.
- Applications appropriate for magnetic flux vector control
 - Machines which require large starting torque
 - Machines which require enough torque at low speed
 - Machines where load fluctuates widely
- Applications inappropriate for magnetic flux vector control
 - Machines where speed fluctuation at low speed is not allowed, e.g. grinder, wrapping machine.

MAGNETIC FLUX VECTOR CONTROL

Parameters related to magnetic flux vector control

Function Number	Function Name	Setting Range	Set Value	Description	Factory Setting
80	Motor capacity	9999, 0.4 to 55kW	9999	V/F control is selected.	○
			0.4 to 55	Motor capacity (kW) is set.	—
81	Number of motor poles	9999, 2, 4, 6 12, 14, 16	9999	V/F control is selected.	○
			2, 4, 6	Number of motor poles is set.	—
			12, 14, 16	Switch on the signal across terminals RT-SD to select V/F control if the number of motor poles has been set. (Control is switched at a stop.) 12: 2-pole motor 14: 4-pole motor 16: 6-pole motor	—
71	Applied motor*	0, 1, 2	0	Standard motor	○
			1	Constant-torque motor	—
			2	Standard motor, 5-point flexible V/F characteristic	—

*The electronic thermal characteristic is also set simultaneously.

V/F SLIP CONTROL

Motor slip is calculated on the basis of i_q during V/F control to make slip compensation.

i_q : torque component current

* The output frequency is risen in the driving load mode and is lowered in the regenerative load mode.

Related parameters

Pr. No.	Function	Setting Range	Increments	Factory Setting	Remarks
107	Slip compensation selection	0, 10	—	0	0—no slip comp. 10—slip comp. selected If Pr. 77 = 2, write during operation is disabled
89	Speed control gain	0 to 1000.0%	0.1%	100.0%	*1

Pr. 107 This parameter selects the FR-A's slip compensation function which will improve speed regulation.

Pr. 89 Use Pr. 89 to adjust the slip compensation value. This parameter determines the amount of speed correction that the slip compensation function will add. Experimentation is usually required.

*1: Pr. 89 is also used for magnetic flux vector control.

Pr. 89 setting value can be read under the following conditions.

- 801 is in Pr. 77 and 9999 is not in Pr. 80 and Pr.81.
- 10 is in Pr. 107.

*2 : Motor slip is calculated on the assumption that the motor capacity is equal to the inverter capacity and the motor pole number is 4 when 10 is set in Pr. 107 with 9999 in Pr. 80 or 9999 in Pr. 81.

*3 : Set values other than 9999 in Pr. 80 and in Pr. 81 to give priority to magnetic flux vector control.

*4 : Slip compensation does not work at the output frequency of 120Hz and above.

SWITCH-OVER FUNCTION

This function allows the operation mode to be switched during operation as follows:

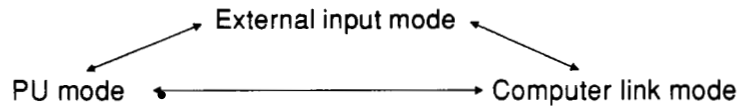

Use Pr. 79 to set the switch-over mode.

Example

Computer (or external) operation ^(A) → PU operation ^(B) → Computer (or external) operation

A: The speed command used for operation in the computer (or external) mode is switched to the speed command to be used for operation in the PU mode.

The operation command used for operation in the computer (or external) mode is switched to the operation command to be used for operation in the PU mode.

B: The speed command used for operation in the PU mode is switched to the speed command to be used for operation in the computer mode (or the set speed of the external potentiometer).

The operation command used for operation in the PU mode is switched to the operation command in the computer mode (or the external operation command).

	Modes Switching	Switching Status	
		(Pr.79 0 to 5 aforementioned)	(Pr.79 6)
1	External to PU	Only during stop, operation via PU	During stop, during operation, operation via PU * The data of the external operation mode is used unchanged for operation in the PU mode.
2	External to computer	Only during stop, computer operation	During stop, during operation, computer operation (*1) * The data of the external operation mode is used unchanged for operation in the computer mode.
3	PU to external	Only during stop, operation via PU	During stop, during operation, operation via PU * The set value of the external variable resistor and the start command on mode switching are used.
4	PU to computer	Only during stop, PU operation is performed to enter the external mode and computer operation is then performed.	During stop, during operation, computer operation (direct) (code E1 0003) * The data of the PU mode is used unchanged for operation in the computer mode.
5	Computer to external	Only during stop, computer operation (code E1 0001 shifts to the PU/external normal mode)	During stop, during operation, computer operation (*1) * The set value of the external variable resistor and the start command on mode switching are used.
6	Computer to PU	Only during stop, computer + PU operation	During stop, during operation, computer operation, PU operation * The data of the computer mode is used unchanged for operation in the PU mode.

*1: External to (PU, computer) : Operation is performed with the STF/STR state shifted to the forward/reverse operation and the external setting f (example: 0-5V, multi-speed, etc.) shifted to the speed in the PU or computer mode.

*2: (PU, computer) to external : Operation is performed according to the speed setting and STF/STR of the external input on mode switching.

*3: (PU, computer) to external (STOP terminal ON): 3-wire operation is performed with the forward/reverse operation in the PU mode used unchanged.

*4: When any mode is switched to the other during operation, the reset code is sent to the PU once and the communication error alarm is displayed but this is not a fault.

*5: The jog operation should be selected or reset from the PU during stop.

(Note) 1. When 6 is set in Pr. 79, PI control will not operate.

2. When "PU operation mode" is assigned to the output terminal, the signal is output as soon as the mode is switched to the PU mode during operation and stop.

3. This function is not available for the PU01E.

7. MAINTENANCE AND INSPECTION

The transistorized inverter is a static unit consisting mainly of semiconductor devices. Daily inspection must be performed to prevent any fault from occurring due to adverse influence by the installation environment, such as temperature, humidity, dust, dirt and vibration, changes in the parts with time, service life, and other factors.

7.1 Precautions for Maintenance and Inspection

- (1) The operator must check power on/off by himself to prevent any person not in charge from misoperating the inverter.
- (2) For some short time after the power is switched off, the capacitor remains charged at a high voltage. Before performing any inspection, make sure that the charge lamp on the printed circuit is off and check that the voltage across the main circuit terminals P and N of the inverter is 30VDC or less using a tester, etc. (For the location of the charge lamp, see the terminal block arrangement on page 106.)

7.2 Check Items

Have a proper understanding of the definitions of power and alarm indications provided for the inverter. Also, have a proper understanding of the settings of electronic overcurrent protection, etc.

(1) Daily inspection

Check for the following:

- (a) Motor operation fault
- (b) Improper installation environment
- (c) Cooling system fault
- (d) Unusual vibration and noise
- (e) Unusual overheat and discoloration

During operation, check the inverter I/O voltages using a tester.

(2) Periodic maintenance and inspection

Check the areas inaccessible during operation and requiring periodic inspection.

- (a) Cooling system: Clean the air filter, etc.
- (b) Screws and bolts: Check that they are securely tightened and retighten as necessary.
- (c) Conductors and insulating materials: Check for corrosion and damage.
- (d) Insulation resistance: Measure.
- (e) Cooling fan, smoothing capacitor, relay: Check and change if necessary.

7. MAINTENANCE AND INSPECTION

(3) Insulation resistance test using megger

- (a) Before performing the insulation resistance test using a megger on the external circuit, disconnect the cables from all terminals of the inverter so that the test voltage is not applied to the inverter.
- (b) For the inverter, conduct the insulation resistance test on the main circuit only as shown in Fig. 7.1 and do not perform the test on the control circuit. (Use a 500VDC megger.)
- (c) For the continuity test of the control circuit, use a tester (high resistance range) and do not use the megger or buzzer.

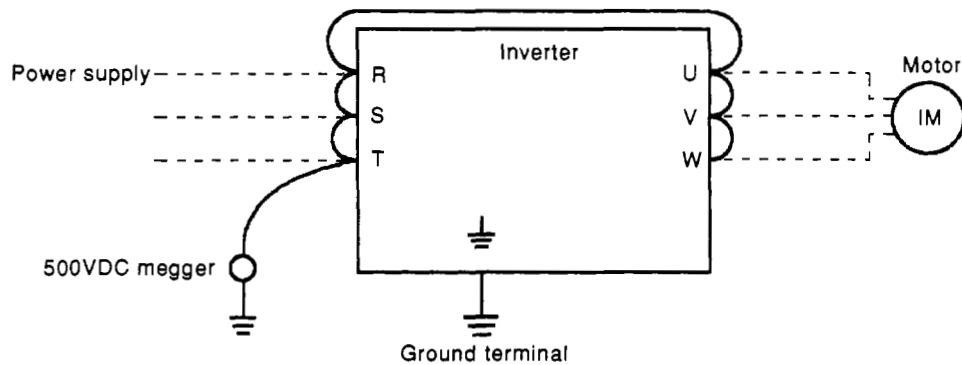

Fig. 7.1 Insulation Resistance Test Using Megger

7. MAINTENANCE AND INSPECTION

Table 1 Daily and Periodic Inspection

Area of inspection	Inspection Item	Description	Interval			Method	Criterion	Instrument
			Daily	Periodic				
				1-year	2-year			
General	Surrounding environment	Check ambient temperature, humidity, dust, dirt, etc.	○			See note on p. 7.	Ambient temperature: -10°C to +50°C, non-freezing. Ambient humidity: 90% or less, non-condensing.	Thermometer, hygrometer, recorder
	Overall unit	Check for unusual vibration and noise.	○			Visual and auditory check.	No fault.	
	Power supply voltage	Check that main circuit voltage is normal.	○			Measure voltage across inverter terminals R-S-T.	170 to 253V (323 to 506V) 50Hz 170 to 242V (323 to 506V) 60Hz	Tester, digital multimeter
Main circuit	General	(1) Check with megger (across main circuit terminals and ground terminal). (2) Check for loose screws and bolts. (3) Check for overheat on each part. (4) Clean.		○	○	(1) Disconnect all cables from inverter and measure across terminals R, S, T, U, V, W and ground terminal with megger. (2) Retighten. (3) Visual check.	(1) 5M or more. (2), (3) No fault	DC 500V class megger
	Conductors, cables	(1) Check conductors for distortion. (2) Check cable sheaths for breakage.		○	○	(1), (2) Visual check.	(1), (2) No fault.	
	Terminal block	Check for damage.		○		Visual check	No fault	
	Inverter module Converter module	Check resistance across terminals.			○	Disconnect cables from inverter and measure across terminals R, S, T and P, N, and across U, V, W and P, N with tester x 1 range.	(See p. 84.)	Analog tester
	Smoothing capacitor	(1) Check for liquid leakage. (2) Check for safety valve projection and bulge. (3) Measure electrostatic capacity.	○		○	(1), (2) Visual check. (3) Measure with capacity meter.	(1), (2) No fault (3) 85% or more of rated capacity.	Capacity meter
	Relay	(1) Check for chatter during operation. (2) Check timer operation time. (3) Check for rough surface on contacts.		○	○	(1) Auditory check. (2) Length of time from power on to relay on. (3) Visual check.	(1) No fault (2) Relay should be switched on in 0.1 to 0.15 seconds. (3) No fault.	Universal counter
	Resistor	(1) Check for crack in resistor insulation. (2) Check for open cable.		○	○	(1) Visual check. Cement resistor, wire-wound resistor. (2) Disconnect one end and measure with tester.	(1) No fault. (2) Error should be within 10% of indicated resistance value.	Tester, digital multimeter
	Control circuit protective circuit	Operation check	(1) Check balance of output voltages across phases with inverter operated independently. (2) Perform sequence protective operation test to make sure of no fault in protective and display circuits.		○		(1) Measure voltage across inverter output terminals U-V-W. (2) Simultaneously connect inverter protective circuit output terminals.	(1) Phase-to-phase voltage balance within 4V for 200V (8V for 400V). (2) Fault must occur because of sequence.
Cooling system	Cooling fan	(1) Check for unusual vibration and noise. (2) Check for loose connection.	○		○	(1) Turn by hand with power off. (2) Retighten.	(1) Smooth rotation. (2) No fault.	
Display	Display	(1) Check for LED lamp blown. (2) Clean.	○		○	(1) Lamps indicate indicator lamps on panel. (2) Clean with rag.	(1) Check that lamps are lit.	
	Meter	Check that reading is normal.	○			(1) Check reading of meters on panel.	(1) Must satisfy specified and management values.	Voltmeter, ammeter, etc.
Motor	General	(1) Check for unusual vibration and noise. (2) Check for unusual odor.	○		○	(1) Auditory, sensory, visual checks. (2) Check for unusual odor due to overheat, damage, etc.	(1), (2) No fault	
	Insulation resistance	(1) Check with megger (across terminals and ground terminal)			○	(1) Disconnect cables from U, V, W, including motor cables.	(1) 5M or more.	500V megger

7. MAINTENANCE AND INSPECTION

7.3 Measurement of Main Circuit Voltages, Currents and Powers

(1) Measurement of voltages and currents

Since the voltages and currents on the inverter power supply and output sides include harmonics, accurate measurement depends on the instruments used and circuits measured.

When instruments for commercial frequency are used for measurement, measure the circuits in Fig. 7.2 using the instruments in Table 2.

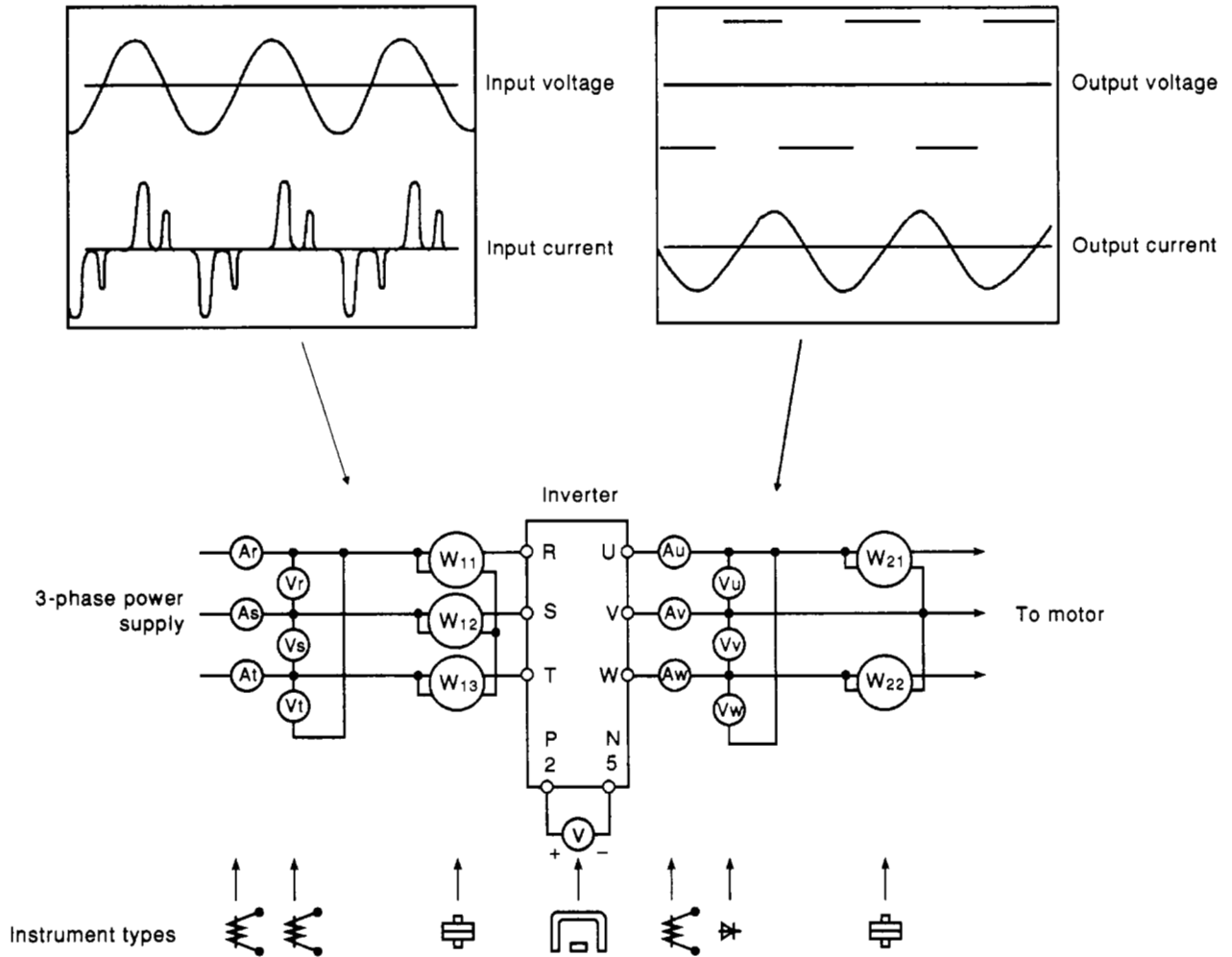

Fig. 7.2 Typical Measuring Points and Instruments

7. MAINTENANCE AND INSPECTION

Table 2 Measuring Points and Instruments

Item	Measuring Point	Measuring Instrument	Remarks (Reference Measured Value) *	
Power supply voltage V ₁	Across R-S, S-T and T-R	Moving-iron type	170 to 242V (342 to 506V) 50Hz 170 to 253V (342 to 506V) 60Hz	
Power supply side current I ₁	R, S, and T line currents	Moving-iron type		
Power supply side power P ₁	At R, S and T, and across R-S, S-T and T-R	Electrodynamic type	P ₁ = W ₁₁ + W ₁₂ + W ₁₃	
Power supply side power factor Pf ₁	Calculate after measuring power supply voltage, power supply side current and power supply side power. $Pf_1 = \frac{P_1}{\sqrt{3} V_{1-L1}} \times 100\%$			
Output side voltage V ₂	Across U-V, V-W and W-U	Rectifier type (not moving-iron type) (note 1)	Difference between phases is within 1% of maximum output voltage.	
Output side current I ₂	U, V and W line currents	Moving-iron type	Current should be equal to or less than rated inverter current. Difference between phases is 10% or lower.	
Output side power P ₂	At U, V and W, and across U-V and V-W	Electrodynamic type	P ₂ = W ₂₁ + W ₂₂	
Output side power factor Pf ₂	Calculate in similar manner to power supply side power factor. $Pf_2 = \frac{P_2}{\sqrt{3} V_{2-I2}} \times 100\%$			
Converter output	Across P-N	Moving-coil type (such as tester)	Inverter LED display is lit. 1.35 x V ₁ Maximum 380V (760V) during regenerative operation	
Frequency setting signal	Across 2-5	Moving-coil type (Tester, etc. may be used) (Internal resistance: 50k or larger)	0 to 5V/0 to 10VDC	"5" is common.
	Across 1-5		0 to ±5V/0 to ±10VDC	
	Across 4-5		4 to 20mADC	
Frequency setting power supply	Across 10-5		5VDC	
	Across 10E-5		10VDC	
Frequency meter signal	Across FM-SD		Approx. 3.5VDC at maximum frequency (without frequency meter)	SD is common.
Start signal Select signal	Across STF, STR, RH, RM, RL, JOG/OH, RT, AU-SD		20 to 30VDC when open ON voltage 1V or less	
Reset	Across RES-SD			
Output stop	Across MRS-SD			
Alarm signal	Across A-C Across B-C	Moving-coil type (such as tester)	Continuity check <Normal> < Fault> Across A-C: Discontinuity Continuity Across B-C: Continuity Discontinuity	

* Values in brackets indicate those for 400V series.

Note 1: Do not use a tester because an accurate data will not be obtained.

7. MAINTENANCE AND INSPECTION

7.4 Checking the Inverter and Converter Modules

- (1) **Preparation**
- Disconnect the external power supply cables (R, S, T), motor cables (U, V, W).
 - Prepare a tester. (Use 1 Ω range.)

(2) **Checking**

Change the polarity of the tester alternately at the inverter terminals R, S, T, U, V, W, P and N, and check for continuity.

Note 1: Before measurement, check that the smoothing capacitor is discharged.

Note 2: At the time of discontinuity, the measured value indicated is a nearly infinite value. Due to the influence of the smoothing capacitor, continuity may instantaneously be established and infinite not indicated. At the time of continuity, the measured value is several to several ten ohms depending on the number of modules, number of parallel modules, circuit tester type, etc. If all measured values are almost the same, the modules are without fault.

		Tester Polarity		Measured Value			Tester Polarity		Measured Value
		+	-				+	-	
Converter module	D1	R	P	Discontinuity	D4	R	N	Continuity	
		P	R	Continuity		N	R	Discontinuity	
	D2	S	P	Discontinuity	D5	S	N	Continuity	
		P	S	Continuity		N	S	Discontinuity	
	D3	T	P	Discontinuity	D6	T	N	Continuity	
		P	T	Continuity		N	T	Discontinuity	
Inverter module	TR1	U	P	Discontinuity	TR4	U	N	Continuity	
		P	U	Continuity		N	U	Discontinuity	
	TR3	V	P	Discontinuity	TR6	V	N	Continuity	
		P	V	Continuity		N	V	Discontinuity	
	TR5	W	P	Discontinuity	TR2	W	N	Continuity	
		P	W	Continuity		N	W	Discontinuity	

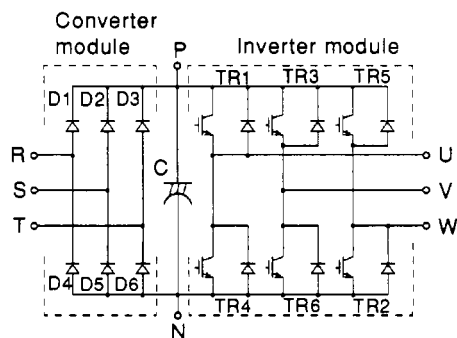

Fig. 7.3 Module Device Numbers and Terminals to Be Checked

7. MAINTENANCE AND INSPECTION

7.5 Replacement of Parts

The inverter consists of many electronic parts such as semiconductor devices. The following parts may deteriorate with age because of their structures or physical characteristics, leading to reduced performance or failure of the inverter. For preventive maintenance, the parts must be changed periodically.

(1) Cooling fan

The cooling fan cools heat-generating parts such as the main circuit semiconductor devices. The life of the cooling fan bearing is usually 10,000 to 35,000 hours. Hence, the cooling fan must be changed every 2 to 3 years if the inverter is run continuously. When unusual noise and/or vibration is noticed during inspection, the cooling fan must be changed immediately.

(2) Smoothing capacitor

A large-capacity aluminum electrolytic capacitor is used for smoothing the DC in the main circuit, and an aluminum electrolytic capacitor is also used for stabilizing the control power supply in the control circuit. Its characteristics are adversely affected by ripple current, etc. When the inverter is operated in ordinary, air-conditioned environment, change the capacitor about every 5 years. When 5 years have elapsed, the capacitor deteriorates more rapidly. Check the capacitor at least every year (less than six months if the life will be expired soon). Check the following:

- 1) Case (side faces and bottom face for expansion)
- 2) Sealing plate (for remarkable warp and extreme crack)
- 3) Explosion-proof valve (for excessive valve expansion and operation)
- 4) Appearance, external crack, discoloration, leakage.

When the measured capacitance of the capacitor has reduced below 85% of the rating, change the capacitor. For capacitance measurement, a handy device is available on the market.

(3) Relays

To prevent contact fault, relays must be changed according to the number of accumulative switching times (switching life). See Table 4 for the inverter parts replacement guide. Lamps and other short-life parts must also be changed during periodic inspection.

Table 4 Replacement Parts of the Inverter

Part Name	Standard Replacement Interval	Description
Cooling fan	2 to 3 years	Change (as required)
Smoothing capacitor in main circuit	5 years	Change (as required)
Smoothing capacitor on circuit board	5 years	Same as above
Relays	—————	Change as required.

8. TROUBLESHOOTING

If any function of the inverter is lost due to occurrence of a fault, establish the cause and make correction in accordance with the following inspection procedure. Contact your sales representative if the corresponding fault is not found below, the inverter has failed, the part has been damaged, or any other fault has occurred.

8.1 Clearing Up the Cause of Fault

Checking the parameter unit display

The display of the parameter unit is switched as follows to indicate the cause of a faulty operation.

Parameter Unit	Cause of Fault	Check Point	Remedy
OC During Acc	Main circuit device overheat	Acceleration too fast? Check for output short circuit or ground fault. Check for cooling fan stop.	Increase acceleration time. Change fan. Remove obstacle to cooling fan. (Note)
Stedy Spd Oc		Sudden load change? Check for output short circuit or ground fault. Check for cooling fan stop.	Keep load stable. Change fan. Remove obstacle to cooling fan. (Note)
OC During Dec		Deceleration too fast? Check for output short circuit or ground fault. Check for cooling fan stop.	Increase deceleration time. Change fan. Remove obstacle to cooling fan. (Note)
Ov During Acc	Overvoltage on DC bus (terminals P-N)	Acceleration too fast?	Increase acceleration time.
Stedy Spd Ov		Sudden load change?	Keep load stable.
Ov During Dec		Deceleration too fast?	Increase deceleration time. (Set deceleration time which matches load GD^2 .)
Motor Overload	Thermal relay for motor	Motor used under overload?	Reduce load. Increase motor and inverter capacities.
Inv. Overload	Thermal relay for inverter		
Inst. Pwr. Loss	Instantaneous power failure	Check the cause of instantaneous power failure occurrence.	
Under Voltage	Drop of power supply voltage	Large-capacity motor started?	Check power system equipment such as power supply capacity.
Br. Cct. Fault	Brake transistor fault	Braking duty correct?	Reduce load GD^2 . Reduce braking duty.
Ground Fault	Ground fault occurred in output circuit.	Check motor and cables for ground fault.	Remedy ground fault area.
OH Fault	External thermal relay operated.	Check motor for overheat.	Reduce load and frequency of operation.
Stll Prev STP	Stall prevention or current limit function activated too long.	Motor used under overload?	Reduce load. Increase motor and inverter capacities.
Option Fault	Option and inverter connected improperly.	Check for loose connector.	Securely connect.
Corrupt Memry	Storage device (EEPROM) capacity exceeded, faulty	Number of parameter write times too many?	Change inverter.
Retry No. Over	Operation could not be resumed within the number of retry times set.	Check cause of alarm occurrence.	
CPU Fault	CPU malfunction		Change inverter.
PU Leave Out	The PU has been disconnected from the connector.	Check that the PU is connected securely.	Securely install the PU.
PU to Inverter comms. Error Inv. Reset ON	<ul style="list-style-type: none"> • Reset signal ON • Loose connection between PU and inverter • Communication circuit fault 	<ul style="list-style-type: none"> • Check for miswiring to reset terminal • Check for loose connector 	<ul style="list-style-type: none"> • Turn the reset signal off • Securely connect • Change inverter

Note: This alarm does not occur due to the cooling fan stop, but it will occur to prevent the power devices from overheating by the fan failure.

8. TROUBLESHOOTING

8.2 Faults and Check Points

Fault	Typical Check Point
Motor does not rotate.	(1) Checking the main circuit <ul style="list-style-type: none"> • Check that the power is applied (inverter LED display is lit). • Check that the motor is connected properly. (2) Checking the input signals <ul style="list-style-type: none"> • Check that the start signal is present. • Check that both the forward and reverse start signals are not present simultaneously. • Check that the frequency setting signal is not at zero. • Check that the signal across terminals AU and SD is on when the frequency setting signal is 4 to 20mA. • Check that the output stop signal (across terminals MRS-SD) or reset signal (across RES-SD) is not on. (3) Checking the function (parameter) set values <ul style="list-style-type: none"> • Check that the reverse rotation prevention (Pr. 78) is not set. • Check that the operation mode (Pr. 79) setting is correct. • Check that the bias and gain (Pr. 902 to Pr. 905) settings are correct. • Check that the starting frequency (Pr. 13) set value is not greater than the running frequency. • Check that various operational functions (such as three-speed operation), especially the maximum frequency, are not zero. (4) Checking the load <ul style="list-style-type: none"> • Check that the load is not too heavy and the shaft is not locked. (5) Others <ul style="list-style-type: none"> • Check that the inverter LED display (ALARM) is not lit.
The motor rotates in opposite direction.	<ul style="list-style-type: none"> • Check that the phase sequence of the output terminals U, V and W is correct. • Check that the start signals (forward, reverse) are connected properly.
Speed greatly differs from the pre-determined value.	<ul style="list-style-type: none"> • Check that the frequency setting signal is proper. (Measure the input signal level.) • Check that the following function (parameter) set values are proper: Maximum frequency (Pr. 1), acceleration/deceleration reference frequency (Pr. 20), acceleration/deceleration time increment (Pr. 21), bias, gain (Pr. 902 to Pr. 905), base frequency voltage (Pr. 19) • Check that the input signal lines are not affected by external noise. (Use of shielded cables)
Acceleration/deceleration is not smooth.	<ul style="list-style-type: none"> • Check that the acceleration/deceleration time set value is not too short. • Check that the load is not too heavy. • Check that the torque boost set value is not too large to activate the current limit function.
Speed varies during operation.	<ul style="list-style-type: none"> • Check that the load is not varying. • Check that the frequency setting signal is not varying. • Check that the settings of the applied motor capacity (Pr. 80) and number of applied motor poles (Pr. 81) are correct for the inverter capacity and motor capacity in magnetic flux vector control. • Check that the wiring length is within 30m in magnetic flux vector control. • Check that the wiring length is proper in V/F control. <p>Remedy: Change the setting of special parameter 97 (Td compensation) to 0. This parameter is displayed only when 801 is set in Pr. 77. Note: Parameters Pr. 82 to 99, which are also displayed simultaneously when 801 is set in Pr. 77, must not be set to protect the inverter from damage. (except Pr. 89)</p>
Motor current is large.	<ul style="list-style-type: none"> • Check that the load is not too heavy. • Check that the torque boost (manual) set value is not too large.
Speed does not increase.	<ul style="list-style-type: none"> • Check that the maximum frequency set value is proper, i.e. it is not too small. • Check that the load is not too heavy. • Check that the torque boost set value is not too large to activate the current limit function.
"PU to inverter comms. error" is displayed on the PU screen.	<ul style="list-style-type: none"> • Check that the reset signal (terminals RES-SD) is not ON. • Check that the PU is connected securely.

Note: Pr. indicates a function number (parameter).

8. TROUBLESHOOTING

8.3 Protective Functions

When any of the protective functions has been activated, switch the power off, then on, or reset the inverter with the reset terminal (RES). (Inverter reset can also be executed in the PU help menu.)

Function	Description	Display		Alarm Code	Alarm Output	
		Parameter unit	Inverter LED			
Acceleration/constant-speed stall prevention current limit	If a current not less than 150%* of the rated inverter current flows in the motor during acceleration, this function stops the increase in frequency until the load current reduces to prevent the inverter from resulting in overcurrent trip. If a current not less than 150% of the rated current flows during steady (constant-speed) operation, this function also lowers the frequency until the load current reduces to prevent the inverter from resulting in overcurrent trip. When the load current has reduced below 150%, this function increases the frequency again and accelerates up to the set speed or continues operation.	OL is shown (during motor rotation).	EOL1 (EOLT)	D	Not provided. Provided by EOLT display.	
Deceleration stall prevention	If the brake operating amount has exceeded the specified value due to excessive regenerative energy during motor deceleration, this function stops the decrease in frequency to prevent the inverter from resulting in overvoltage trip. As soon as the regenerative energy has reduced, this function reduces the frequency again and continues deceleration.	Still Prev STP (at a motor stop)	(Indicates a stop due to the activation of the function for a long time during constant-speed operation.)			
Overcurrent shut-off	When the inverter output current has reached or exceeded 200% of the rated current, the protective circuit is activated to stop the inverter.	During acceleration	OC During Acc	EOL1	1	Provided
		During constant-speed operation	Stedy Spd Oc	EOL2	2	
		During deceleration	Oc During Dec	EOL3	3	
Regenerative overvoltage shut-off	When a d.c. bus overvoltage is caused by regenerative energy from the motor, the protective circuit is activated to stop the transistor output and keep it stopped.	During acceleration	Ov During Acc	EOV1	4	Provided
		During constant-speed operation	Stedy Spd Ov	EOV2		
		During deceleration	Ov During Dec	EOV3		
Instantaneous power failure protection	If instantaneous power failure has occurred in excess of 15 msec (this applies also to inverter input power shut-off), this function is activated to stop the inverter output and keep it stopped. At this time, the alarm output contacts are open (across B-C). (If the power failure is within 15msec, the control circuit operates without fault. If the power failure continues for more than about 100msec, the protective circuit is reset.)	Inst. Pwr. Loss	EIPF (EIPF)	7	Provided	
Undervoltage protection	If the inverter power supply voltage has reduced, the control circuit cannot operate properly, resulting in the decrease in motor torque and/or the increase in heat generation. To prevent this, if the power supply voltage reduces below about 150V (300V for the 400V series), this function stops the inverter output.	Under Voltage	EUVT (EUVT)	8	Provided	
Brake transistor alarm detection	If the brake transistor fault has occurred due to extremely large regenerative brake duty, etc., this function detects that fault and stops the inverter output.	Br. Cct. Fault	EBE (EBE)	A	Provided	
Overload shut-off (electronic overcurrent protection)	The electronic overcurrent protection in the inverter detects motor overload during rated operation or motor overheat during low-speed operation, activates the protective circuit, and stops the inverter output and keeps it stopped. When, for example, a multi-pole motor or more than one motor is driven, the motor(s) cannot be protected by the electronic overcurrent protection. Provide a thermal relay in the inverter output circuit. In this case, setting the electronic overcurrent protection value to 0A activates the inverter protection only. (Activated at a current 150% or more of the rated current.)	Motor Overload	ETHM (ETHM)	5	Provided	
		Inv. Overload	Inverter protection ETHI (ETHI)	6		

Note: See page 90 for the alarm codes.

8. TROUBLESHOOTING

Function	Description	Display		Alarm Code	Alarm Output
		Parameter unit	Inverter LED		
Brake resistor over-heat protection	If the regenerative brake amount from the motor has exceeded the specified value, the brake operation is stopped to protect the brake resistor from overheat. When the brake resistor has cooled, the brake operation is resumed.	(Not displayed)	(Not displayed)	—	Not provided
Output side ground fault overcurrent protection	If a ground fault current has flown due to a ground fault occurring in the output (load) side of the inverter, this function stops the inverter output. A ground fault occurring at low ground resistance may activate the overcurrent protection (OC1 to OC3).	Ground Fault	E OF (EGF)	B	Provided
External thermal relay operation	If the external thermal relay for motor overheat protection or the internally mounted temperature relay in the motor has been switched on (relay contacts open), this function stops the inverter output and keeps it stopped. This protection is only provided when the external thermal relay input function has been selected.	OH Fault	E OHT (EOHT)	C	Provided
Inboard option connection alarm	Stops the inverter output if the dedicated option used in the inverter results in connection (connector) fault during operation.	Option Fault	E OPT (EOPT)	E	Provided
Parameter storage device alarm	Stops the output if the specified number of write times (100,000 times) to EEPROM, which stores the function set values, has been exceeded or a device fault has occurred.	Corrupt Memry	E PE (EPE)	F	Provided
Retry count exceeded	If operation cannot be resumed within the number of retry times set, this function stops the inverter output.	Retry No. Over	E RET (ERET)	F	Provided
CPU error	If the operation of the built-in CPU does not end within a predetermined period of time, the inverter self-determines it as alarm and stops the output.	CPU Fault	E CPU (ECPU)	F	Provided
Parameter unit dis-connection	Stops the inverter output if the parameter unit is disconnected. This protective function is activated only when the PU disconnection detection function has been selected.	PU Leave Out	E PUE (EPUE)	F	Provided

Note: See page 90 for the alarm codes.

8. TROUBLESHOOTING

8.4 Alarm Code Output

The setting of Pr. 76 (alarm code output selection) allows alarm definition to be output as a 4-bit digital signal. The signal is output from the open collector output terminals equipped as standard for the inverter. Correlation between alarm definitions and alarm codes are as follows.

Alarm Definition (Protective Function)	Inverter LED Display	Output Terminal Signal On/Off*				(Alarm Code)	
		SU	IPF	OL	FU		
Normal operation	—	0	0	0	0	0	
Overcurrent shut-off	During acceleration	E.OC1	0	0	0	1	1
	During constant-speed operation	E.OC2	0	0	1	0	2
	During deceleration	E.OC3	0	0	1	1	3
Regenerative overvoltage shut-off	E.OV1 to 3	0	1	0	0	4	
Electronic overcurrent protector	Motor protection	E.THM	0	1	0	1	5
	Inverter protection	E.THT	0	1	1	0	6
Instantaneous power failure	E.IPF	0	1	1	1	7	
Undervoltage	E.UVT	1	0	0	0	8	
Brake transistor alarm	E.BE	1	0	1	0	A	
Output side ground fault/overcurrent	E.GF	1	0	1	1	B	
External thermal relay operation	E.OHT	1	1	0	0	C	
Stall-activated stop	E.OLT	1	1	0	1	D	
Inboard option alarm	E.OPT	1	1	1	0	E	
Parameter storage device alarm	E.PE	1	1	1	1	F	
Retry count exceeded	E.RET						
CPU error	E.CPU						
Parameter unit disconnection	E.PUE						

*0: output transistor off, 1: output transistor on (common terminal: SE)

9. OPTION

9.1 Option List

	Option Name	Type	Application, Specifications, Etc.	Applicable Inverter
Inboard type (dedicated to FR-A)	Industrial equipment compatible function	FR-APA	<ul style="list-style-type: none"> • 12-bit digital input • PLG feedback control (Note 1) • Extension analog output 	Common to all models
	Computer link function	FR-APB	<ul style="list-style-type: none"> • RS422, RS485 interface for computer link (serial communication) • PLG feedback control 	
	Programmable controller link function	FR-APC	<ul style="list-style-type: none"> • MELSECNET/MINI-S3 (optical cable) interface • PLG feedback control 	
	Automatic control compatible function	FR-APD	<ul style="list-style-type: none"> • P1 control (Note 2) 	
	I/O function	FR-APE	<ul style="list-style-type: none"> • 12-bit digital input • Relay output (3 points) • Extension analog output 	
External option (dedicated to FR-A)	Parameter unit (English)	FR-PU02E	Interactive parameter unit using LCD display. The LCD display and ten-key pad of the FR-PU02 are indicated in English.	0.4K to 55K According to capacity
	Parameter copy unit (English)	FR-ARWE	Allows set parameters to be read in batch and copied to the other inverter. The LCD display and ten-key pad of the FR-ARW are indicated in English.	
	Drip shield	FR-ACA □□	This option allows conduit to be connected to the inverter and the inverter to be changed to an enclosed structure model (NEMA1).	

(Note 1) The FR-APA orientation function is described in the option manual, but it will not operate with the FR-A200-U/UL inverters.

(Note 2) The FR-APD battery back-up function is described in the option manual, but it will not operate with the FR-A200-U/UL inverters.

9. OPTION

	Option Name	Type	Application, Specifications, Etc.	Applicable Inverter
External option	Power factor improving DC reactor	FR-BEL(H) *	Used to improve the inverter input power factor (overall power factor about 95%).	5.5K to 55K According to capacity
	Parameter unit cable	FR-CBL <input type="checkbox"/>	Cable for connection with the parameter unit or parameter copy unit Straight or L shape type available	Common to all models
	Brake unit	FR-BU-(H) *	Used to improve the braking capability of the inverter (for high-inertia load or negative load)	15K to 55K According to capacity
	Resistor unit	FR-BR-(H) *	Use the brake unit and resistor unit together.	
	Power return unit	FR-RC-(H) *	Energy-saving, high-function brake unit which can return the motor-generated braking energy to the power supply	

* Type for 400 VAC class has H.

9. OPTION

9.2 Inboard Dedicated Options

Option	Functions						
	PLG feedback control	12-bit digital input	Relay output	Extension analog output	Computer link (serial communication)	MELSECNET/ MINI-S3 Interface	PI control
FR-APA (industrial equipment compatible function)	○	○		○			
FR-APB (computer link function)	○				○		
FR-APC (programmable controller link function)	○					○	
FR-APD (automatic control compatible function)							○
FR-APE (I/O function)		○	○	○			

Out of the above option cards, only one can be installed in the inverter. Each option card has several functions as listed above. Orientation function is described in the FR-APA option manual, and battery back-up function in the FR-APD option manual, but they will not operate with the FR-A200-U/UL inverters.

	Function, Application, Etc.	Rating, Etc.
PLG feedback control	<ul style="list-style-type: none"> The motor speed is detected by the pulse encoder, this detection signal is fed back to the inverter, and its speed variation is automatically compensated for. Hence, the motor speed can be kept constant if load variation occurs. The actual motor speed can be monitored on the inverter LED display and parameter unit. <p>Application example: extruder, winder, transfer equipment, etc.</p>	<ul style="list-style-type: none"> Speed variation ratio: within 0.2% at the load variation of 0 ~ 100% (*) (at 1800rpm) Applicable motor: standard motor of 4 ~ 8 poles Encoder specifications: 3 phase, differential output, 1024P/rev. 5VDC power supply Example: Tamagawa Seiki's TS 1508 N 207, etc. (*) Load of 100% indicates the continuous operation torque of the motor at each running frequency.
12-bit digital input	<ul style="list-style-type: none"> Input interface used to set the inverter frequency accurately using external BCD or binary digital signals. Either 12-bit binary or BCD 3-digit signal can be selected. Gain and offset can also be adjusted. 	<ul style="list-style-type: none"> Input voltage, current: 24VDC, 5mA (per circuit) Input signal format: contact signal input or transistor open collector (sink type) input Example: MELSEC AY40, AY40A, etc.

9. OPTION

	Function, Application, Etc.	Rating, Etc.
Relay output (3 points)	<ul style="list-style-type: none"> Any three signals can be selected and output as relay contacts (change-over contacts) from among the 10 standard output signals (RUN, SU, IPF/UVT, OL, FU1, FU2, RBP, THP, PRG, PU) of the inverter. 	<ul style="list-style-type: none"> Signal types: change-over contact (three output relays installed) Contact capacity: 230VAC 0.3A 30VDC 0.3A
Extension analog output	<ul style="list-style-type: none"> 16 signals which can be monitored on the FM and AM terminals, such as output frequency, output voltage, output current and motor torque, are expanded and output. A 1mADC or 5VDC (10V) meter can be connected. Gain and offset can also be adjusted. 	<ul style="list-style-type: none"> Output voltage (across LM2-LM0): 0 ~ 10VDC, max. 1mA Output current (across LM1-LM0): 0 ~ 1mA Output resolution: 3mV for voltage output 1μA for current output Output accuracy: ±10%
Computer link function	<ul style="list-style-type: none"> Allows inverter operation/monitoring and parameter read/write to be performed using user program from a computer, e.g. personal computer or FA controller, which is connected by communication cables. Noiseless communication system using twisted pair cables. 	<ul style="list-style-type: none"> Conforming standard: EIA Standard, for RS422 and RS485 Transmission format: multidrop link system Communication speed: max. 9600 baud rates Max. number of inverters connected: RS422 10 inverters RS485 32 inverters Overall extension: 500m
MELSECNET/MINI-S3 interface	<ul style="list-style-type: none"> Allows inverter operation/monitoring and parameter read/write to be performed using user program from the programmable controller in the Mitsubishi programmable controller data link system MELSECNET/MINI-S3 which is connected by optical fiber. Communication is made via optical link system. 	<ul style="list-style-type: none"> Max. number of inverters connected: 16 inverters (up to 64 inverters when used with remote I/O stations) Interstation transmission distance: 50m max., 1m min.
PI control	<ul style="list-style-type: none"> PI control function is required when process control, e.g. flow rate, air volume or pressure, is carried out by the inverter. The set value can be set from any of terminal 2, 1 or parameter unit. The measured value (feedback signal) is input to terminal 4 by a 4-20mA current signal. 	<ul style="list-style-type: none"> PI control range: proportional band: 1 ~ 1000% integral time: 0.1 ~ 3600 seconds Output signal: high limit, low limit, during forward rotation, during reverse rotation

9. OPTION

Connection Examples

• PLG feedback control

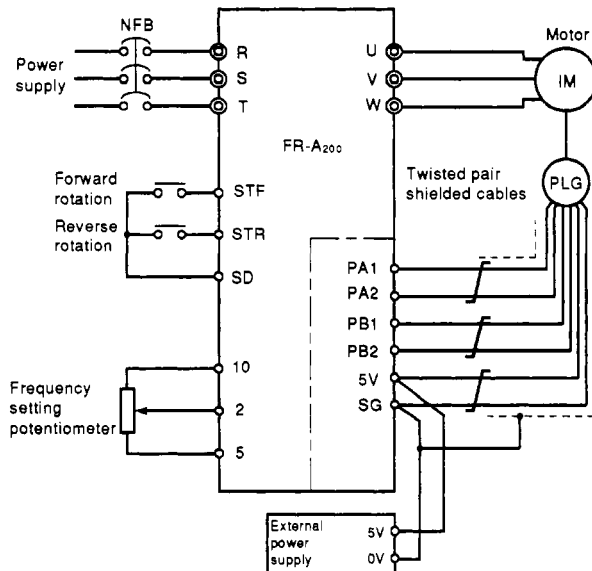

• PI control (for pressure control)

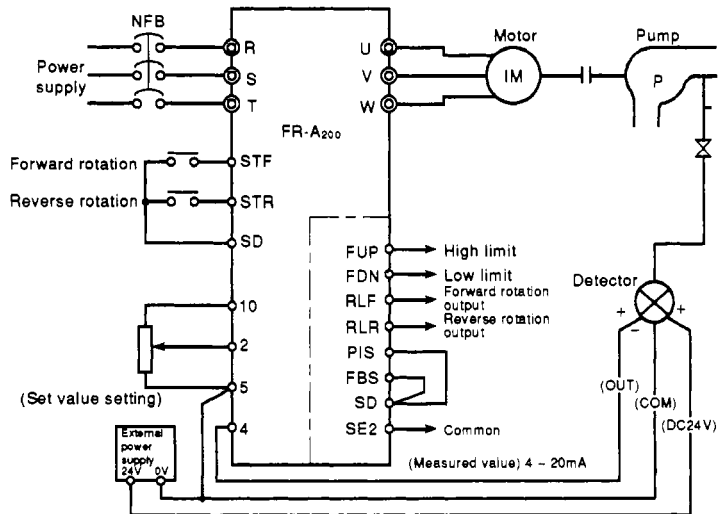

• 12-bit digital input (for BCD code)

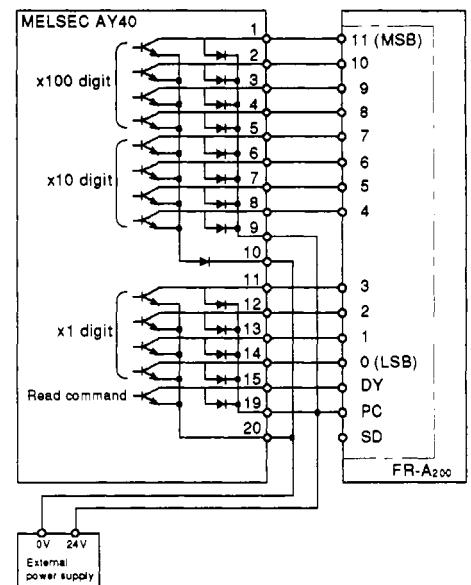

• Extension analog output

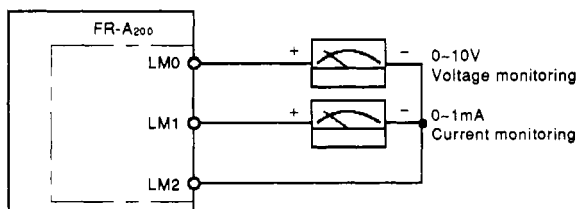

(For contact signal)

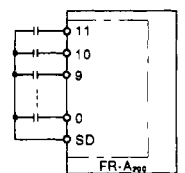

9. OPTION

9.3 External Dedicated Options

Option (Type)	Specifications, Structure, Etc.	Remarks																																			
Parameter copy unit FR-ARW (Japanese) FR-ARWE (English)	<ul style="list-style-type: none"> Allows parameters set to application to be read in batch and easily written to another inverter. External dimensions are the same as those of the FR-PU02E parameter unit. Can also be used as the parameter unit. <p style="text-align: right;">Unit: mm</p> <p style="text-align: center;">The keys marked * have different functions from those of FR-PU02(E).</p>	The FR-ZRW(E) used with the Z series cannot be used.																																			
Accessory cover	<ul style="list-style-type: none"> When the parameter unit is removed from the inverter, this cover is fitted to that position. This cover can be fitted and removed by a single action. <p style="text-align: right;">Unit: mm</p>	This cover is supplied to the model without the parameter unit.																																			
Drip shield FR-ACA <input type="checkbox"/> <input type="checkbox"/>	<ul style="list-style-type: none"> By installing this option, the inverter can be changed to be an enclosed structure model (NEMA1) and conduit can be connected to the inverter. Adequate for wall mounting application, etc. Note 1: This structure is not protected from water and fluid entry and is therefore not appropriate for environments often exposed to water drop and oily smoke. Note 2: This option is fitted then the maximum ambient temperature for operation of the inverter is reduced to + 40 °C. For dimensions, refer to the FR-A200 catalog. <table border="1" data-bbox="944 1205 1455 1579"> <thead> <tr> <th rowspan="2">Type</th> <th colspan="2">Applicable Inverter</th> </tr> <tr> <th>200V series</th> <th>400V series</th> </tr> </thead> <tbody> <tr> <td>FR-ACA01</td> <td>FR-A220-0.4K-UL</td> <td>—</td> </tr> <tr> <td>FR-ACA02</td> <td>FR-A220-0.75K-UL</td> <td>—</td> </tr> <tr> <td>FR-ACA03</td> <td>FR-A220-1.5K-UL</td> <td>—</td> </tr> <tr> <td>FR-ACA04</td> <td>FR-A220-2.2K/3.7K-UL</td> <td>FR-A240-0.4K/0.75K/1.5K/2.2K/3.7K-UL</td> </tr> <tr> <td>FR-ACA05</td> <td>FR-A220-5.5K/7.5K-UL</td> <td>FR-A240-5.5K/7.5K-UL</td> </tr> <tr> <td>FR-ACA06</td> <td>FR-A220-11K/15K-UL</td> <td>FR-A240-11K/15K-UL</td> </tr> <tr> <td>FR-ACA07</td> <td>FR-A220-18.5K/22K-UL</td> <td>FR-A240-18.5K/22K-UL</td> </tr> <tr> <td>FR-ACA08</td> <td>FR-A220-30K-UL</td> <td>—</td> </tr> <tr> <td>FR-ACA09</td> <td>FR-A220-37K-UL</td> <td>FR-A240-30K/37K-UL</td> </tr> <tr> <td>FR-ACA10</td> <td>FR-A220-45K/55K-UL</td> <td>FR-A240-45K/55K-UL</td> </tr> </tbody> </table>	Type	Applicable Inverter		200V series	400V series	FR-ACA01	FR-A220-0.4K-UL	—	FR-ACA02	FR-A220-0.75K-UL	—	FR-ACA03	FR-A220-1.5K-UL	—	FR-ACA04	FR-A220-2.2K/3.7K-UL	FR-A240-0.4K/0.75K/1.5K/2.2K/3.7K-UL	FR-ACA05	FR-A220-5.5K/7.5K-UL	FR-A240-5.5K/7.5K-UL	FR-ACA06	FR-A220-11K/15K-UL	FR-A240-11K/15K-UL	FR-ACA07	FR-A220-18.5K/22K-UL	FR-A240-18.5K/22K-UL	FR-ACA08	FR-A220-30K-UL	—	FR-ACA09	FR-A220-37K-UL	FR-A240-30K/37K-UL	FR-ACA10	FR-A220-45K/55K-UL	FR-A240-45K/55K-UL	
Type	Applicable Inverter																																				
	200V series	400V series																																			
FR-ACA01	FR-A220-0.4K-UL	—																																			
FR-ACA02	FR-A220-0.75K-UL	—																																			
FR-ACA03	FR-A220-1.5K-UL	—																																			
FR-ACA04	FR-A220-2.2K/3.7K-UL	FR-A240-0.4K/0.75K/1.5K/2.2K/3.7K-UL																																			
FR-ACA05	FR-A220-5.5K/7.5K-UL	FR-A240-5.5K/7.5K-UL																																			
FR-ACA06	FR-A220-11K/15K-UL	FR-A240-11K/15K-UL																																			
FR-ACA07	FR-A220-18.5K/22K-UL	FR-A240-18.5K/22K-UL																																			
FR-ACA08	FR-A220-30K-UL	—																																			
FR-ACA09	FR-A220-37K-UL	FR-A240-30K/37K-UL																																			
FR-ACA10	FR-A220-45K/55K-UL	FR-A240-45K/55K-UL																																			

indicates that the attachment changes according to the inverter capacity.

9. OPTION

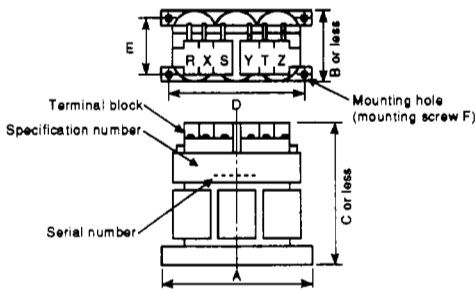
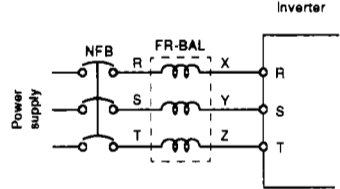
Option (Type)	External Dimensions (Unit: mm)	Wiring, Etc.																																																																																																																																																																																																																																													
Power factor improving AC reactor (for power coordination) FR-BAL-(H)□□K		<p>• Input power factor: about 0.9</p>  <p>Note: 1. The input power factor is improved to 0.9. 2. Select the reactor according to the motor capacity. If the inverter capacity is greater than the motor capacity, select the reactor according to the motor capacity. 3. Use the reactor for 22KW when a 18.5K inverter is used.</p>																																																																																																																																																																																																																																													
	<table border="1" style="width: 100%; border-collapse: collapse;"> <thead> <tr> <th rowspan="2">Capacity</th> <th colspan="6">FR-BAL</th> <th rowspan="2">Weight (kg)</th> <th colspan="6">FR-BAL-H</th> <th rowspan="2">Weight (kg)</th> </tr> <tr> <th>A</th> <th>B</th> <th>C</th> <th>D</th> <th>E</th> <th>F</th> <th>A</th> <th>B</th> <th>C</th> <th>D</th> <th>E</th> <th>F</th> </tr> </thead> <tbody> <tr><td>0.4KW</td><td>135</td><td>64</td><td>120</td><td>120</td><td>45</td><td>M4</td><td>2</td><td>125</td><td>64</td><td>120</td><td>120</td><td>45</td><td>M4</td><td>2.1</td></tr> <tr><td>0.75KW</td><td>135</td><td>74</td><td>120</td><td>120</td><td>57</td><td>M4</td><td>3</td><td>150</td><td>76</td><td>145</td><td>145</td><td>55</td><td>M4</td><td>3.7</td></tr> <tr><td>1.5KW</td><td>160</td><td>76</td><td>145</td><td>145</td><td>55</td><td>M4</td><td>4</td><td>150</td><td>92</td><td>145</td><td>145</td><td>70</td><td>M4</td><td>5.3</td></tr> <tr><td>2.2KW</td><td>160</td><td>96</td><td>145</td><td>145</td><td>75</td><td>M4</td><td>6</td><td>150</td><td>96</td><td>145</td><td>145</td><td>75</td><td>M4</td><td>5.9</td></tr> <tr><td>3.7KW</td><td>220</td><td>95</td><td>200</td><td>200</td><td>70</td><td>M5</td><td>8.5</td><td>220</td><td>95</td><td>195</td><td>200</td><td>70</td><td>M5</td><td>8.5</td></tr> <tr><td>5.5KW</td><td>220</td><td>101</td><td>200</td><td>200</td><td>75</td><td>M5</td><td>9.5</td><td>220</td><td>101</td><td>200</td><td>200</td><td>75</td><td>M5</td><td>9.5</td></tr> <tr><td>7.5KW</td><td>220</td><td>125</td><td>205</td><td>200</td><td>100</td><td>M5</td><td>14.5</td><td>220</td><td>125</td><td>200</td><td>200</td><td>100</td><td>M5</td><td>14</td></tr> <tr><td>11KW</td><td>280</td><td>140</td><td>245</td><td>255</td><td>100</td><td>M6</td><td>19</td><td>280</td><td>140</td><td>235</td><td>255</td><td>100</td><td>M6</td><td>18.5</td></tr> <tr><td>15KW</td><td>295</td><td>156</td><td>280</td><td>270</td><td>110</td><td>M6</td><td>27</td><td>295</td><td>156</td><td>270</td><td>270</td><td>110</td><td>M8</td><td>27</td></tr> <tr><td>22KW</td><td>290</td><td>200</td><td>300</td><td>240</td><td>170</td><td>M8</td><td>35</td><td>290</td><td>200</td><td>300</td><td>240</td><td>170</td><td>M8</td><td>35</td></tr> <tr><td>30KW</td><td>290</td><td>220</td><td>300</td><td>240</td><td>190</td><td>M8</td><td>43</td><td>290</td><td>220</td><td>300</td><td>240</td><td>190</td><td>M8</td><td>43</td></tr> <tr><td>37KW</td><td>330</td><td>240</td><td>310</td><td>270</td><td>190</td><td>M10</td><td>50</td><td>330</td><td>220</td><td>360</td><td>270</td><td>190</td><td>M10</td><td>50</td></tr> <tr><td>45KW</td><td>330</td><td>240</td><td>360</td><td>270</td><td>190</td><td>M10</td><td>60</td><td>330</td><td>220</td><td>410</td><td>270</td><td>190</td><td>M10</td><td>60</td></tr> <tr><td>55KW</td><td>330</td><td>245</td><td>400</td><td>270</td><td>190</td><td>M10</td><td>70</td><td>330</td><td>220</td><td>450</td><td>270</td><td>190</td><td>M10</td><td>70</td></tr> </tbody> </table>	Capacity	FR-BAL						Weight (kg)	FR-BAL-H						Weight (kg)	A	B	C	D	E	F	A	B	C	D	E	F	0.4KW	135	64	120	120	45	M4	2	125	64	120	120	45	M4	2.1	0.75KW	135	74	120	120	57	M4	3	150	76	145	145	55	M4	3.7	1.5KW	160	76	145	145	55	M4	4	150	92	145	145	70	M4	5.3	2.2KW	160	96	145	145	75	M4	6	150	96	145	145	75	M4	5.9	3.7KW	220	95	200	200	70	M5	8.5	220	95	195	200	70	M5	8.5	5.5KW	220	101	200	200	75	M5	9.5	220	101	200	200	75	M5	9.5	7.5KW	220	125	205	200	100	M5	14.5	220	125	200	200	100	M5	14	11KW	280	140	245	255	100	M6	19	280	140	235	255	100	M6	18.5	15KW	295	156	280	270	110	M6	27	295	156	270	270	110	M8	27	22KW	290	200	300	240	170	M8	35	290	200	300	240	170	M8	35	30KW	290	220	300	240	190	M8	43	290	220	300	240	190	M8	43	37KW	330	240	310	270	190	M10	50	330	220	360	270	190	M10	50	45KW	330	240	360	270	190	M10	60	330	220	410	270	190	M10	60	55KW	330	245	400	270	190	M10	70	330	220	450	270	190	M10	70	
Capacity	FR-BAL						Weight (kg)	FR-BAL-H						Weight (kg)																																																																																																																																																																																																																																	
	A	B	C	D	E	F		A	B	C	D	E	F																																																																																																																																																																																																																																		
0.4KW	135	64	120	120	45	M4	2	125	64	120	120	45	M4	2.1																																																																																																																																																																																																																																	
0.75KW	135	74	120	120	57	M4	3	150	76	145	145	55	M4	3.7																																																																																																																																																																																																																																	
1.5KW	160	76	145	145	55	M4	4	150	92	145	145	70	M4	5.3																																																																																																																																																																																																																																	
2.2KW	160	96	145	145	75	M4	6	150	96	145	145	75	M4	5.9																																																																																																																																																																																																																																	
3.7KW	220	95	200	200	70	M5	8.5	220	95	195	200	70	M5	8.5																																																																																																																																																																																																																																	
5.5KW	220	101	200	200	75	M5	9.5	220	101	200	200	75	M5	9.5																																																																																																																																																																																																																																	
7.5KW	220	125	205	200	100	M5	14.5	220	125	200	200	100	M5	14																																																																																																																																																																																																																																	
11KW	280	140	245	255	100	M6	19	280	140	235	255	100	M6	18.5																																																																																																																																																																																																																																	
15KW	295	156	280	270	110	M6	27	295	156	270	270	110	M8	27																																																																																																																																																																																																																																	
22KW	290	200	300	240	170	M8	35	290	200	300	240	170	M8	35																																																																																																																																																																																																																																	
30KW	290	220	300	240	190	M8	43	290	220	300	240	190	M8	43																																																																																																																																																																																																																																	
37KW	330	240	310	270	190	M10	50	330	220	360	270	190	M10	50																																																																																																																																																																																																																																	
45KW	330	240	360	270	190	M10	60	330	220	410	270	190	M10	60																																																																																																																																																																																																																																	
55KW	330	245	400	270	190	M10	70	330	220	450	270	190	M10	70																																																																																																																																																																																																																																	

9. OPTION

Option (Type)	External Dimensions (Unit: mm)	Wiring, Etc.																																																																																																																																																																																																																																																																
Power factor improving DC reactor FR-BEL-(H)□□K	<table border="1" style="width:100%; border-collapse: collapse; font-size: small;"> <thead> <tr> <th>Type</th> <th>A</th> <th>B</th> <th>C</th> <th>D</th> <th>E</th> <th>F</th> <th>G</th> <th>H</th> <th>Weight (kg)</th> <th>Fig.</th> </tr> </thead> <tbody> <tr> <td rowspan="10" style="text-align: center;">200V</td> <td>3.7K</td> <td>150</td> <td>75</td> <td>102</td> <td>2</td> <td>135</td> <td>6</td> <td>M4</td> <td>40</td> <td>1.7</td> <td>1</td> </tr> <tr> <td>5.5K</td> <td>150</td> <td>75</td> <td>126</td> <td>2</td> <td>135</td> <td>6</td> <td>M5</td> <td>40</td> <td>2.2</td> <td>1</td> </tr> <tr> <td>7.5K</td> <td>150</td> <td>75</td> <td>126</td> <td>2</td> <td>135</td> <td>6</td> <td>M5</td> <td>40</td> <td>2.3</td> <td>1</td> </tr> <tr> <td>11K</td> <td>170</td> <td>93</td> <td>132</td> <td>2.3</td> <td>155</td> <td>6</td> <td>M5</td> <td>50</td> <td>3.1</td> <td>1</td> </tr> <tr> <td>15K</td> <td>170</td> <td>93</td> <td>170</td> <td>2.3</td> <td>155</td> <td>6</td> <td>M8</td> <td>56</td> <td>3.8</td> <td>2</td> </tr> <tr> <td>18.5K</td> <td>185</td> <td>94</td> <td>184</td> <td>2.6</td> <td>165</td> <td>7</td> <td>M8</td> <td>56</td> <td>5.1</td> <td>2</td> </tr> <tr> <td>22K</td> <td>185</td> <td>119</td> <td>182</td> <td>2.6</td> <td>165</td> <td>7</td> <td>M8</td> <td>70</td> <td>5.4</td> <td>2</td> </tr> <tr> <td>30K</td> <td>185</td> <td>119</td> <td>201</td> <td>2.6</td> <td>165</td> <td>7</td> <td>M8</td> <td>70</td> <td>6.7</td> <td>2</td> </tr> <tr> <td>37K</td> <td>195</td> <td>136</td> <td>215</td> <td>2.6</td> <td>175</td> <td>7</td> <td>M10</td> <td>70</td> <td>7.4</td> <td>2</td> </tr> <tr> <td>45K</td> <td>195</td> <td>136</td> <td>215</td> <td>2.6</td> <td>175</td> <td>7</td> <td>M10</td> <td>70</td> <td>8.0</td> <td>2</td> </tr> <tr> <td>55K</td> <td>195</td> <td>136</td> <td>246</td> <td>3.2</td> <td>175</td> <td>9</td> <td>M12</td> <td>80</td> <td>9.8</td> <td>2</td> </tr> <tr> <td rowspan="10" style="text-align: center;">400V</td> <td>H3.7K</td> <td>150</td> <td>75</td> <td>102</td> <td>2</td> <td>135</td> <td>6</td> <td>M4</td> <td>40</td> <td>1.7</td> <td>1</td> </tr> <tr> <td>H5.5K</td> <td>150</td> <td>75</td> <td>124</td> <td>2</td> <td>135</td> <td>6</td> <td>M4</td> <td>40</td> <td>2.2</td> <td>1</td> </tr> <tr> <td>H7.5K</td> <td>150</td> <td>75</td> <td>124</td> <td>2</td> <td>135</td> <td>6</td> <td>M4</td> <td>40</td> <td>2.3</td> <td>1</td> </tr> <tr> <td>H11K</td> <td>170</td> <td>93</td> <td>132</td> <td>2.3</td> <td>155</td> <td>6</td> <td>M5</td> <td>50</td> <td>3.1</td> <td>1</td> </tr> <tr> <td>H15K</td> <td>170</td> <td>93</td> <td>160</td> <td>2.3</td> <td>155</td> <td>6</td> <td>M6</td> <td>56</td> <td>3.7</td> <td>2</td> </tr> <tr> <td>H18.5K</td> <td>185</td> <td>94</td> <td>173</td> <td>2.6</td> <td>165</td> <td>7</td> <td>M6</td> <td>56</td> <td>4.8</td> <td>2</td> </tr> <tr> <td>H22K</td> <td>185</td> <td>119</td> <td>171</td> <td>2.6</td> <td>165</td> <td>7</td> <td>M6</td> <td>70</td> <td>5.0</td> <td>2</td> </tr> <tr> <td>H30K</td> <td>185</td> <td>119</td> <td>189</td> <td>2.6</td> <td>165</td> <td>7</td> <td>M6</td> <td>70</td> <td>6.7</td> <td>2</td> </tr> <tr> <td>H37K</td> <td>195</td> <td>136</td> <td>199</td> <td>2.6</td> <td>175</td> <td>7</td> <td>M8</td> <td>70</td> <td>7.0</td> <td>2</td> </tr> <tr> <td>H45K</td> <td>195</td> <td>138</td> <td>219</td> <td>3.2</td> <td>175</td> <td>9</td> <td>M8</td> <td>80</td> <td>8.6</td> <td>2</td> </tr> <tr> <td>H55K</td> <td>195</td> <td>138</td> <td>219</td> <td>3.2</td> <td>175</td> <td>9</td> <td>M8</td> <td>80</td> <td>9.0</td> <td>2</td> </tr> </tbody> </table>	Type	A	B	C	D	E	F	G	H	Weight (kg)	Fig.	200V	3.7K	150	75	102	2	135	6	M4	40	1.7	1	5.5K	150	75	126	2	135	6	M5	40	2.2	1	7.5K	150	75	126	2	135	6	M5	40	2.3	1	11K	170	93	132	2.3	155	6	M5	50	3.1	1	15K	170	93	170	2.3	155	6	M8	56	3.8	2	18.5K	185	94	184	2.6	165	7	M8	56	5.1	2	22K	185	119	182	2.6	165	7	M8	70	5.4	2	30K	185	119	201	2.6	165	7	M8	70	6.7	2	37K	195	136	215	2.6	175	7	M10	70	7.4	2	45K	195	136	215	2.6	175	7	M10	70	8.0	2	55K	195	136	246	3.2	175	9	M12	80	9.8	2	400V	H3.7K	150	75	102	2	135	6	M4	40	1.7	1	H5.5K	150	75	124	2	135	6	M4	40	2.2	1	H7.5K	150	75	124	2	135	6	M4	40	2.3	1	H11K	170	93	132	2.3	155	6	M5	50	3.1	1	H15K	170	93	160	2.3	155	6	M6	56	3.7	2	H18.5K	185	94	173	2.6	165	7	M6	56	4.8	2	H22K	185	119	171	2.6	165	7	M6	70	5.0	2	H30K	185	119	189	2.6	165	7	M6	70	6.7	2	H37K	195	136	199	2.6	175	7	M8	70	7.0	2	H45K	195	138	219	3.2	175	9	M8	80	8.6	2	H55K	195	138	219	3.2	175	9	M8	80	9.0	2		<p>• Input power factor: about 0.95</p> <p>Note: 1. The link across inverter terminals P-P1 must be disconnected. (If it is not disconnected, there is no power factor improvement.) 2. The wiring distance from the inverter should be within 5m. 3. The size of the cable used should be identical to or larger than that of the power supply cable (R, S, T). (See page 121.) 4. Select the reactor according to the motor capacity. (If the inverter capacity is greater than the motor capacity, select the reactor according to the motor capacity.) 5. Note that this reactor can not be connected to the inverters of 3.7K and down. * To be used when a 3.7kW motor is used with the 5.5K inverter.</p>
	Type	A	B	C	D	E	F	G	H	Weight (kg)	Fig.																																																																																																																																																																																																																																																							
	200V	3.7K	150	75	102	2	135	6	M4	40	1.7	1																																																																																																																																																																																																																																																						
		5.5K	150	75	126	2	135	6	M5	40	2.2	1																																																																																																																																																																																																																																																						
		7.5K	150	75	126	2	135	6	M5	40	2.3	1																																																																																																																																																																																																																																																						
		11K	170	93	132	2.3	155	6	M5	50	3.1	1																																																																																																																																																																																																																																																						
		15K	170	93	170	2.3	155	6	M8	56	3.8	2																																																																																																																																																																																																																																																						
		18.5K	185	94	184	2.6	165	7	M8	56	5.1	2																																																																																																																																																																																																																																																						
		22K	185	119	182	2.6	165	7	M8	70	5.4	2																																																																																																																																																																																																																																																						
		30K	185	119	201	2.6	165	7	M8	70	6.7	2																																																																																																																																																																																																																																																						
		37K	195	136	215	2.6	175	7	M10	70	7.4	2																																																																																																																																																																																																																																																						
		45K	195	136	215	2.6	175	7	M10	70	8.0	2																																																																																																																																																																																																																																																						
	55K	195	136	246	3.2	175	9	M12	80	9.8	2																																																																																																																																																																																																																																																							
	400V	H3.7K	150	75	102	2	135	6	M4	40	1.7	1																																																																																																																																																																																																																																																						
		H5.5K	150	75	124	2	135	6	M4	40	2.2	1																																																																																																																																																																																																																																																						
		H7.5K	150	75	124	2	135	6	M4	40	2.3	1																																																																																																																																																																																																																																																						
		H11K	170	93	132	2.3	155	6	M5	50	3.1	1																																																																																																																																																																																																																																																						
		H15K	170	93	160	2.3	155	6	M6	56	3.7	2																																																																																																																																																																																																																																																						
		H18.5K	185	94	173	2.6	165	7	M6	56	4.8	2																																																																																																																																																																																																																																																						
		H22K	185	119	171	2.6	165	7	M6	70	5.0	2																																																																																																																																																																																																																																																						
		H30K	185	119	189	2.6	165	7	M6	70	6.7	2																																																																																																																																																																																																																																																						
		H37K	195	136	199	2.6	175	7	M8	70	7.0	2																																																																																																																																																																																																																																																						
		H45K	195	138	219	3.2	175	9	M8	80	8.6	2																																																																																																																																																																																																																																																						
	H55K	195	138	219	3.2	175	9	M8	80	9.0	2																																																																																																																																																																																																																																																							
	Parameter unit cable (FR-CBL □□)																																																																																																																																																																																																																																																																	
		<table border="1" style="width:100%; border-collapse: collapse; font-size: small;"> <thead> <tr> <th>Type</th> <th>Length l (m)</th> </tr> </thead> <tbody> <tr> <td>Straight</td> <td>L</td> </tr> <tr> <td>FR-CBL01</td> <td>FR-CBL-L1</td> <td>1</td> </tr> <tr> <td>FR-CBL03</td> <td>FR-CBL-L3</td> <td>3</td> </tr> <tr> <td>FR-CBL05</td> <td>FR-CBL-L5</td> <td>5</td> </tr> </tbody> </table>	Type	Length l (m)	Straight	L	FR-CBL01	FR-CBL-L1	1	FR-CBL03	FR-CBL-L3	3	FR-CBL05	FR-CBL-L5	5	<p>The PU side connector of this L type can be fixed with the accessory screws.</p>																																																																																																																																																																																																																																																		
Type	Length l (m)																																																																																																																																																																																																																																																																	
Straight	L																																																																																																																																																																																																																																																																	
FR-CBL01	FR-CBL-L1	1																																																																																																																																																																																																																																																																
FR-CBL03	FR-CBL-L3	3																																																																																																																																																																																																																																																																
FR-CBL05	FR-CBL-L5	5																																																																																																																																																																																																																																																																

10. SPECIFICATIONS

10.1 Standard Specifications

■200V Series

Type FR-A220- □□ -UL		0.4K	0.75K	1.5K	2.2K	3.7K	5.5K	7.5K	11K	15K	18.5K	22K	30K	37K	45K	55K	
HP rating	CT	0.5	1	2	3	5	7.5	10	15	20	25	30	40	50	60	75	
	VT	1	1.5	3	3	5	10	10	20	25	30	40	50	60	75	100	
Output	Rated capacity (kVA) * 2	1.1	1.9	3.1	4.2	6.5	9.2	12.6	17.6	23.3	29	34	44	55	67	82	
	Continuous Current	CT	3	5	8	11	17	24	33	46	61	76	90	115	145	175	215
		VT	3.6	5	9.6	12	18	28	37	54	68	80	104	130	154	185	248
	Overload Current Rating *3	CT	150% 60 seconds, 200% 0.5 seconds (inverse-time characteristics)														
		VT	120% 60 seconds, 150% 0.5 seconds (inverse-time characteristics)														
	Voltage * 4		Three phase, 200V to 220V 50Hz, 200 to 230V 60Hz														
Regenerative braking torque	Maximum value/time	150%/5S			100%/5S			100%/5S			20% • 5						
	Permissible duty	3%ED			3%ED			2%ED			Continuous • 5						
Power supply	Rated input AC voltage, frequency	Three phase, 200V to 220V 50Hz, 200 to 230V 60Hz															
	Permissible AC voltage fluctuation	170 to 242V 50Hz, 170 to 253V 60Hz															
	Permissible frequency fluctuation	±5%															
	Power supply capacity (kVA) * 6	1.5	2.5	4.5	5.5	9	12	17	20	28	34	41	52	66	80	100	
Protective structure		Enclosed type (IP20)							Open type (IP00)								
Cooling system		Forced air cooling															
Approx. weight (kg) (with PU) **		2.1	2.5	3.3	3.5	3.7	7.5	8	14	14.5	17	17	29	50	69	70	

** : The value for the 7.5K or down is approximate weight including that of the PU.

10. SPECIFICATIONS

■400V Series

Type FR-A240- [] -UL		0.4K	0.75K	1.5K	2.2K	3.7K	5.5K	7.5K	11K	15K	18.5K	22K	30K	37K	45K	55K	
HP rating	CT	0.5	1	2	3	5	7.5	10	15	20	25	30	40	50	60	75	
	VT	1	1.5	3	3	5	10	10	20	25	30	40	50	60	75	100	
Output	Rated capacity (kVA) * 2	1.1	1.9	3	4.2	6.9	9.1	13	17.5	23.6	29	32.8	43.4	54	65	84	
	Continuous Current	CT	1.5	2.5	4	6	9	12	17	23	31	38	43	57	71	86	110
		VT	1.8	3	4.8	6.7	9	14	21	27	34	40	52	65	77	92	124
	Overload Current Rating *3	CT	150% 60 seconds, 200% 0.5 seconds (inverse-time characteristics)														
		VT	120% 60 seconds, 150% 0.5 seconds (inverse-time characteristics)														
	Voltage * 4		Three phase, 380V to 460V 50/60Hz														
	Regenerative braking torque	Maximum value/time	100%/5S							20% * 5							
Permissible duty		2%ED							Continuous * 5								
Power supply	Rated input AC voltage, frequency	Three phase, 380V to 460V 50/60Hz															
	Permissible AC voltage fluctuation	323 to 506V 50/60Hz															
	Permissible frequency fluctuation	±5%															
	Power supply capacity (kVA) * 6	1.5	2.5	4.5	5.5	9	12	17	20	28	34	41	52	66	80	100	
Protective structure		Enclosed type (IP20)							Open type (IP00)								
Cooling system		Forced air cooling															
Approx. weight (kg) (with PU) **		4.0	4.0	4.0	4.5	4.5	8.2	8.2	16	16	20	20	54	54	72	72	

** : The value for the 7.5K or down is approximate weight including that of the PU.

10. SPECIFICATIONS

Common Specifications

Control specifications	Control system		High carrier frequency sine-wave PWM control (V/F control or magnetic flux vector control can be selected)	
	Output frequency range		0.2 ~ 400Hz	
	Frequency setting resolution	Analog input	0.015Hz/60Hz (terminal 2 input: 12 bits/0 ~ 10V, 11 bits/0 ~ 5V, terminal 1 input: 12 bits/-10 ~ +10V, 11 bits/-5 ~ +5V)	
		Digital input	0.01Hz/60Hz	
	Frequency accuracy		Within $\pm 0.2\%$ of maximum output frequency (at $25^{\circ}\text{C} \pm 10^{\circ}\text{C}$)/analog input, within 0.01% of set output frequency/digital input	
	Voltage/frequency characteristic		Base frequency set as required between 0 and 400Hz. Constant torque or variable torque pattern can be selected.	
	Starting torque		150%/1Hz (for magnetic flux vector control)	
	Torque boost		Manual and automatic torque boost	
	Acceleration/deceleration time setting		0 ~ 3600 seconds (acceleration and deceleration can be set individually), linear or S-pattern acceleration/deceleration mode can be selected.	
	DC dynamic brake		Operation frequency (0 ~ 120Hz), operation time (0 ~ 10 seconds), voltage (0 ~ 30%) variable	
Stall prevention operation level		Current limit can be set (0 ~ 200% variable), presence or absence can be selected.		
Operational specifications	Frequency setting signal	Analog input	0 ~ 5VDC, 0 ~ 10VDC, 0 ~ ± 5 VDC, 0 ~ ± 10 VDC, 4 ~ 20mADC	
		Digital input	BCD 3-digit or 12-bit binary using parameter unit (when the FR-APA or FR-APE option is used)	
	Input signals	Start signal		Forward and reverse rotations individual, start signal self-holding input (3-wire input) can be selected.
		Multi-speed selection		Up to 7 speeds can be selected. (Each speed can be set between 0 and 400Hz, running speed can be changed during operation from the parameter unit.)
		Second acceleration/deceleration time selection		0 ~ 3600 seconds (acceleration and deceleration can be set individually)
		Jogging operation selection		Provided with jogging (JOG) mode select terminal * 7
		Current input selection		Input of frequency setting signal 4 ~ 20mADC (terminal 4) is selected.
		Output stop		Shut-off of inverter output (frequency, voltage)
		Alarm reset		Alarm retained at the activation of protective function is reset.
	Operation functions		Maximum/minimum frequency setting, frequency jump operation, external thermal relay input selection, polarity reversible operation, automatic restart operation after instantaneous power failure, commercial power supply-inverter switch-over operation, forward/reverse rotation prevention, slip compensation, operation mode selection	
Operational Specifications	Output signals	Operation status		4 types can be selected from inverter running, up to frequency, instantaneous power failure (undervoltage), frequency detection, second frequency detection, during PU operation, overload alarm, regenerative brake prealarm, and electronic overcurrent protector prealarm. Open collector output
		Alarm (inverter trip)		Contact output...change-over contact (230VAC 0.3A, 30VDC 0.3A) Open collector...alarm code output
		For meter		1 type can be selected from output frequency, motor current (steady or peak value), output voltage, frequency set value, running speed, motor torque, converter output voltage (steady or peak value), regenerative brake operation factor, electronic overcurrent protector load factor, input power, output power, load meter, and motor exciting current. Pulse train output (1440Hz/full scale) or analog output (0 to 10VDC).

10. SPECIFICATIONS

Display	Display on parameter unit or inverter LED	Operating status	Output frequency, motor current (steady or peak value), output voltage, frequency set value, running speed, motor torque, overload, converter output voltage (steady or peak value), motor torque, electronic overcurrent protector load factor, input power, output power, load meter, motor exciting current, cumulative operation time, regenerative brake duty
		Alarm definition	Alarm definition is displayed when protective function is activated. 8 alarm definitions are stored.
	Additional display to parameter unit only	Operating status	Presence or absence of input terminal signal, state of output terminal signal
		Alarm definition	Output voltage/current/frequency/I/O terminal state immediately before protective function is activated
		Interactive guidance	Operation guide, troubleshooting, graphic display by help function
Protective/alarm functions			Overcurrent shut-off (during acceleration, deceleration, constant speed), regenerative overvoltage shut-off, undervoltage, instantaneous power failure, overload shut-off (electronic overcurrent protector), brake transistor alarm*8, ground fault current, output short circuit, main circuit device overheat, stall prevention, overload alarm, brake resistor overheat protection
Environment	Ambient temperature		-10 ~ +50°C (non-freezing), -10 ~ +40°C when the drip shield (FR-ACA) is used.
	Ambient humidity		90%RH or less (non-condensing)
	Storage temperature * 9		-20°C ~ +65°C
	Ambience		No corrosive gases, oil mist, dust and dirt indoors
	Altitude, vibration		Below 1000m, 5.9m/S ² (0.6G) or less (conforms to JIS C 0911)

- Note: ♣ 1 : The applicable motor capacity indicated is the maximum applicable capacity when the Mitsubishi 4-pole standard motor is used.
- * 2 : The rated output capacity indicated assumes that the output voltage is 220V for the 200V series and 440V for the 400V series.
- * 3 : The % value of the overload current rating indicates a ratio to the rated output current of the inverter. For repeated use, it is necessary to wait until the inverter and motor return to temperature below the value at 100% load.
- ♣ 4 : The maximum output voltage does not exceed the power supply voltage. Below the power supply voltage, the maximum output voltage can be set as required.
- * 5 : Indicates the average torque at a time when the inverter is decelerated to a stop from 60Hz. Depends on the motor loss.
- * 6 : The power supply capacity depends on the value of impedance on the power supply side (including the input reactor and cables).
- * 7 : Jogging operation can also be performed from the parameter unit.
- * 8 : Not provided for the FR-A220-11K to 55K and FR-A240-11K to 55K which do not have a built-in brake circuit.
- ♣ 9 : Temperature applicable for a short period in transit, etc.
- * 10 : Where a power supply is 342V and below or 484V and above for the 400V class inverters, change the position of the jumper to the internal transformer, according to page 13.
- * 11 : Short Circuit Ratings
The drive is suitable for use on a Circuit Capable of delivering not more than ___ ♣ ___ RMS Symmetrical Amperes, 500 volts Maximum.

HP rating	*
0 ~ 1	1.000
1.5 ~ 50	5.000
51 ~ 200	10.000

10. SPECIFICATIONS

10.2 Block Diagram

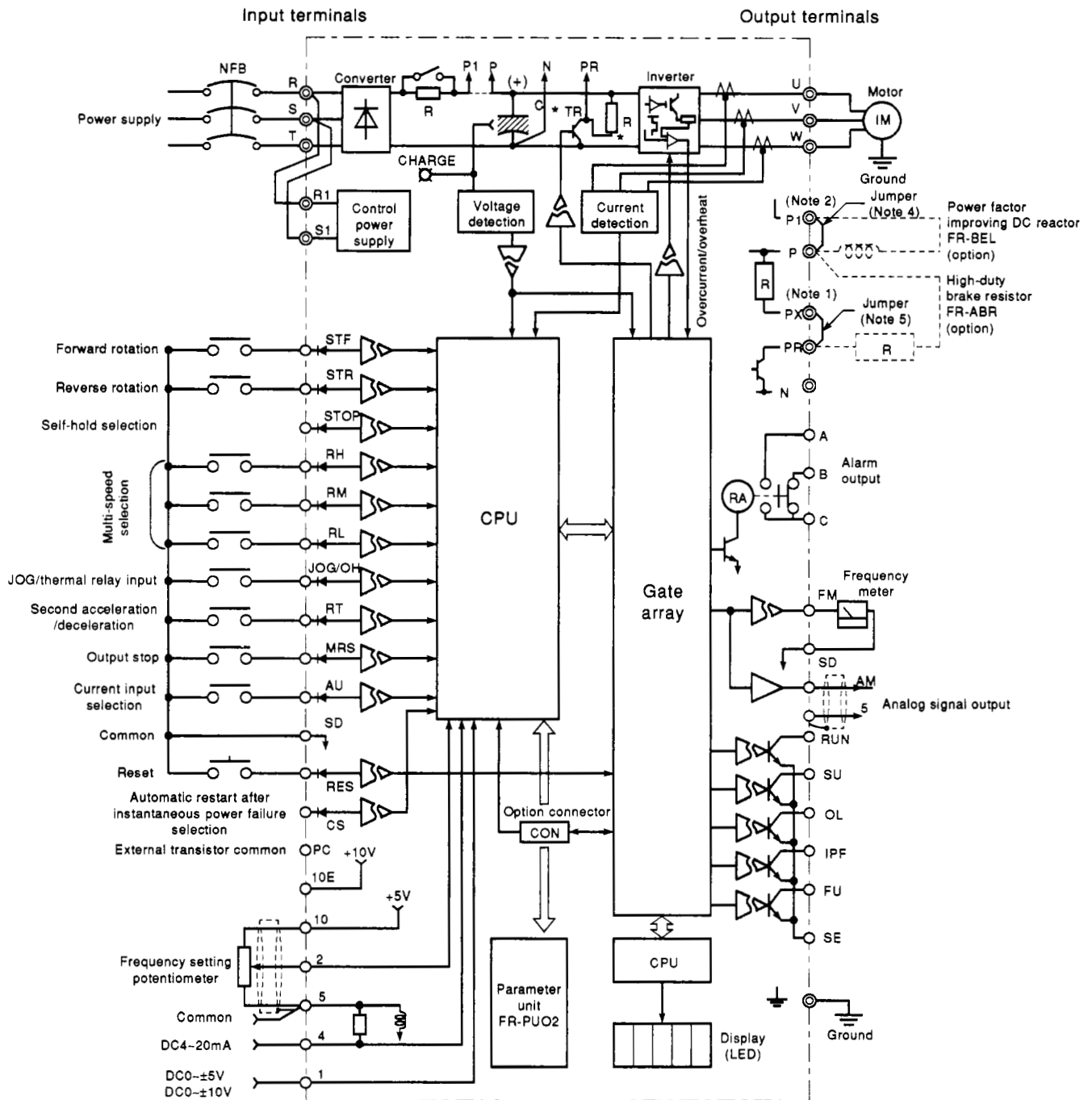

- Note: 1. Terminals PR and PX are provided for the FR-A220-0.4K to 7.5K and FR-A240-0.4K to 7.5K.
 2. Terminal P1 is provided for the FR-A220-5.5K to 55K and FR-A240-5.5K to 55K.
 * 3. The models of 11K and up are not provided with the built-in brake resistor and brake transistor.
 4. When the FR-BEL is used, disconnect this jumper.
 5. When the FR-ABR, FR-BU (brake unit) or FR-RC (power return unit) is used, disconnect this jumper.

10. SPECIFICATIONS

10.3 Terminals

Type	Symbol	Terminal name	Description	
Main circuit	R, S, T	AC power input	Connect to commercial power supply.	
	U, V, W	Inverter output	Connect a three-phase squirrel-cage motor.	
	R1, S1	Power supply for control circuit	Connected to the AC power supply terminals R and S. To retain the alarm display and alarm output, remove the jumper from terminal block and apply external power to these terminals.	
	P, PR	Brake resistor connection	Disconnect the jumper from terminals PR-PX and connect the optional brake resistor (FR-ABR) across terminals P-PR.	
	P, N	Brake unit connection	Connect the optional FR-BU brake unit or power regenerative converter (FR-RC).	
	P, P1	Power factor improving DC reactor connection	Disconnect the jumper from terminals P-P1 and connect the optional power factor improving reactor (FR-BEL).	
	PR, PX	Built-in brake circuit connection	When the jumper is connected across terminals PX-PR (factory setting), the built-in brake resistor is valid.	
		Ground	For grounding the inverter chassis. Must be earthed.	
Control circuit (input signals) Contact (start, function selection, etc.)	STF	Forward rotation start	Turn on the signal across STF-SD for forward rotation and turn off to stop.	When the signals across terminals STF-SD and STR-SD are turned on simultaneously, the stop command is given.
	STR	Reverse rotation start	Turn on the signal across STR-SD for reverse rotation and turn off to stop.	
	STOP	Start self-holding selection	Turn on the signal across terminals STOP-SD to select the self-holding of the start signal.	
	RH, RM, RL	Multi-speed selection	Turn on the signal across RH/RM/RL-SD as appropriate to select up to 7 speeds. Act as group 1, 2 and 3 select signals in the programmed operation mode.	
	JOG/OH	JOG mode selection or external thermal relay input	Turn on the signal across terminals JOG-SD to select jog operation (factory setting). Jog operation can be performed with the start signal (STF or STR). Can also be used as the thermal relay contact input terminal to stop the inverter by the operation of the external thermal relay.	
	RT	Second acceleration /deceleration time selection	Turn on the signal across terminals RT-SD to select the second acceleration/deceleration time. When the second torque boost and second V/F (base frequency) functions have been set, these functions can also be selected by turning on the signal across terminals RT-SD.	
	MRS	Output stop	Turn on the signal across terminals MRS-SD (20ms or longer) to stop the inverter output. Used to shut off the inverter output to bring the motor to a stop by the magnetic brake.	
	RES	Reset	Used to reset the protective circuit activated. Turn on the signal across terminals RES-SD for more than 0.1 sec, then turn it off.	
	AU	Current input selection	Only when the signal across terminals AU-SD is turned on, the inverter can be operated with the 4-20mADC frequency setting signal.	
	CS	Automatic restart after instantaneous power failure selection	When the signal across terminals CS-SD has been turned on, restart can be made automatically when the power is restored after instantaneous power failure. Note that this operation requires restart parameters to be set. When the inverter is shipped from the factory, it is set to disallow restart.	
	SD	Contact input common	Common to the contact input terminals and terminal FM. Isolated from the common terminal of the control circuit.	
PC	External transistor common	When transistor output (open collector output), such as a programmable controller (PC), is connected, connect the external power supply for transistor output to this terminal to prevent fault caused by sneak current.		

10. SPECIFICATIONS

Type	Symbol	Terminal name	Description		
Control circuit (input signals)	Analog frequency setting	10E	Frequency setting power supply	10VDC, permissible load current 10mA	When the frequency setting potentiometer is connected in the factory-set state, connect it to terminal 10. When it is connected to terminal 10E, change the input specifications of terminal 2.
		10		5VDC, permissible load current 10mA	
	2	Frequency setting (voltage)	By entering 0 ~ 5VDC (0 ~ 10VDC), the maximum output frequency is reached at 5V (or 10V) and I/O are proportional. Switch between input 0 ~ 5VDC (factory setting) and 0 ~ 10VDC from the parameter unit. Input resistance 10k. Max. permissible voltage 20V.		
	4	Frequency setting (current)	By entering 4 ~ 20mADC, the maximum output frequency is reached at 20mA and I/O are proportional. This input signal is valid only when the signal across terminals AU-SD is on. Input resistance 250. Max. permissible current 30mA.		
	1	Auxiliary frequency setting	By entering 0 ~ ±5VDC or 0 ~ ±10VDC, this signal is added to the frequency setting signal of terminal 2 or 4. Switch between input 0 ~ ±5VDC and 0 ~ ±10VDC (factory setting) from the parameter unit. Input resistance 10k. Permissible voltage ± 20V.		
	5	Frequency setting input common	Common to the frequency setting signals (terminals 2, 1 or 4) and analog output terminal AM. Not isolated from the common circuit of the control circuit. Do not ground.		
Control circuit (output signals)	Contact	A, B, C	Alarm output	Change-over contact output indicating that the output has been stopped by the inverter protective function activated. 200VAC 0.3A, 30VDC 0.3A. Alarm: discontinuity across B-C (continuity across A-C), normal: continuity across B-C (discontinuity across A-C).	
		RUN	Inverter running	Switched low when the inverter output frequency is equal to or higher than the starting frequency (factory set to 0.5Hz, variable). Switched high during stop or DC dynamic brake operation(**). Permissible load 24VDC 0.1A.	
	Open collector	SU	Up-to-frequency ***	Switched low when the output frequency has reached within 10% of the set frequency (factory setting, variable). Switched high during acceleration, deceleration, or stop(**). Permissible load 24VDC 0.1A.	
		OL	Overload alarm ***	Switched low when the current limit function has caused stall prevention to be activated. Switched high when stall prevention is reset (**). Permissible load 24VDC 0.1A.	
		IPF	Instantaneous power failure ***	Switched low when instantaneous power failure or undervoltage protection is activated(**). Permissible load 24VDC 0.1A.	
		FU	Frequency detection ***	Switched low when the output frequency has reached or exceeded the detection frequency set optionally. Switched high when below the detection frequency(**). Permissible load 24VDC 0.1A.	
		SE	Open collector output common	Common to the RUN, SU, OL, IPF and FU terminals. Isolated from the common circuit of the control circuit.	
	Pulse	FM	For meter	One selected from 16 monitoring items, such as output frequency, is output. The output signal is proportional to the magnitude of each monitoring item. Terminals FM and AM cannot be used at the same time.	Factory-set output item: frequency Permissible load current 1mA 1440Hz at 60Hz. (Max. frequency 2400Hz)
Analog	AM	Analog signal output		Factory-set output item: frequency Output signal 0 ~ 10VDC Permissible load current 1mA. (Max. voltage 10VDC)	

* Terminals PR, PX are provided for the FR-A220-0.4K to 7.5K and FR-A240-0.4K to 7.5K.

** Low indicates that the open collector outputting transistor is on (conducts). High indicates that the transistor is off (does not conduct).

*** The output of these terminals can be reassigned by Pr. 40.

10. SPECIFICATIONS

10.4 Terminal Block Arrangement

Terminal Block for Main Circuit 200V Series

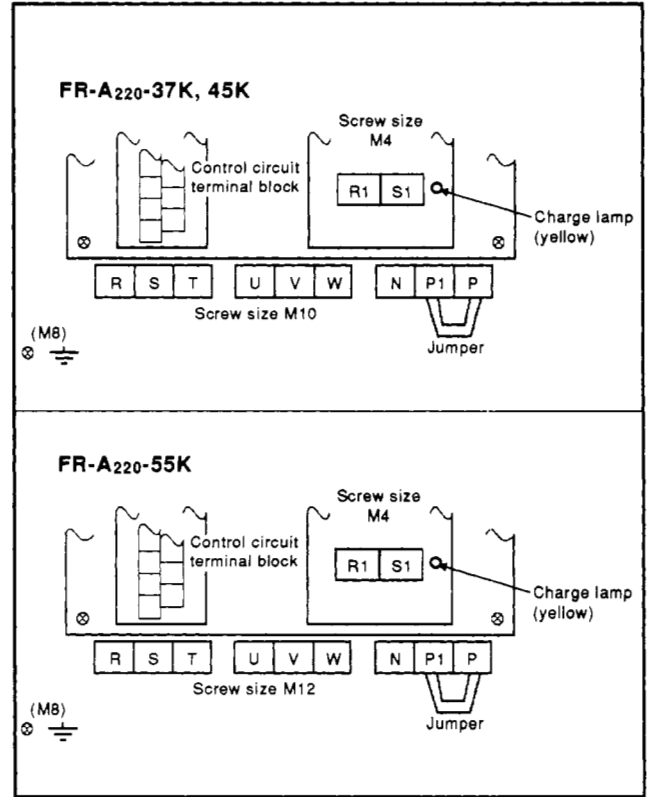
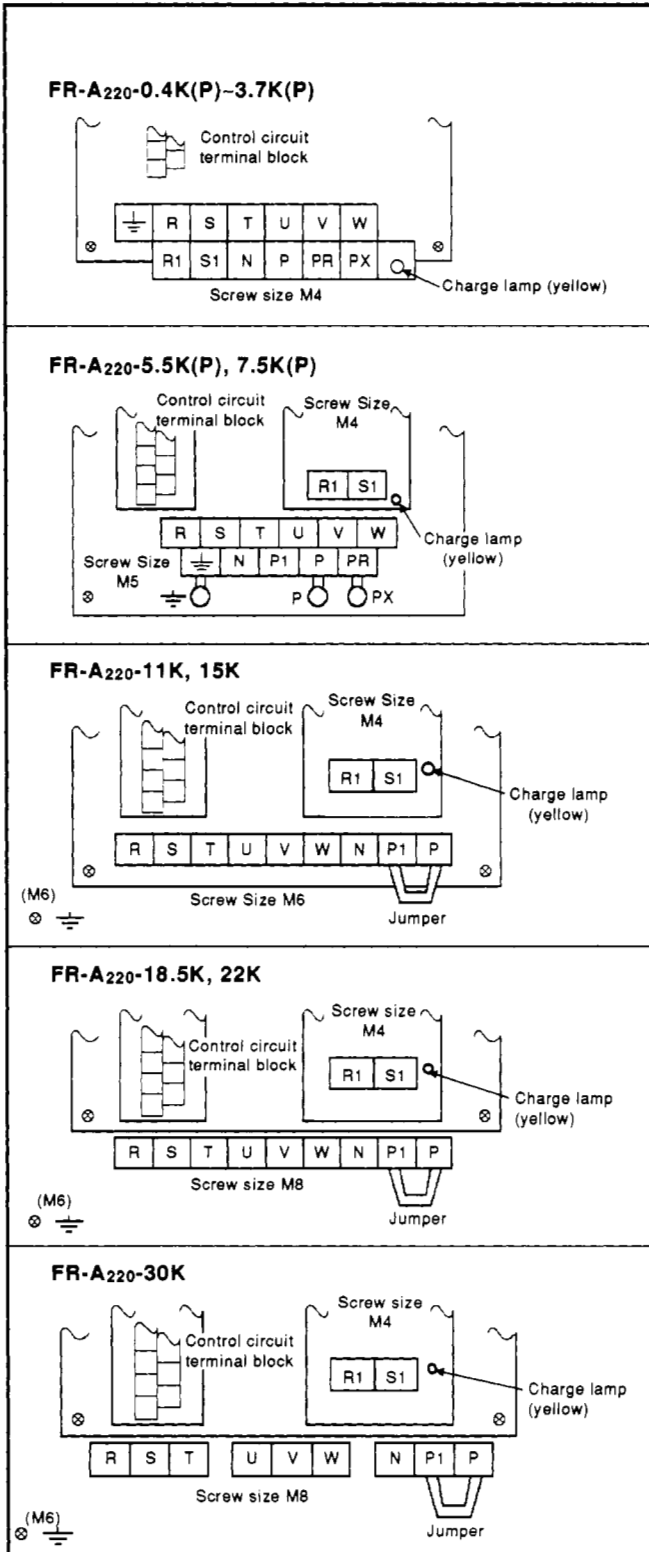

Terminal Block for Control Circuit

Common to all models

Structure.....Two-stage
molded terminals

Screw sizeM3

A	
B	
C	
SE	
RUN	
SU	
IPF	
OL	
FU	
FM	
SD	
RL	
RM	
RH	
RT	
AU	
STOP	
MRS	
RES	AM
SD	10E
STF	10
STR	2
JOG/OH	5
CS	4
PC	1

10. SPECIFICATIONS

Terminal Block for Main Circuit 400V Series

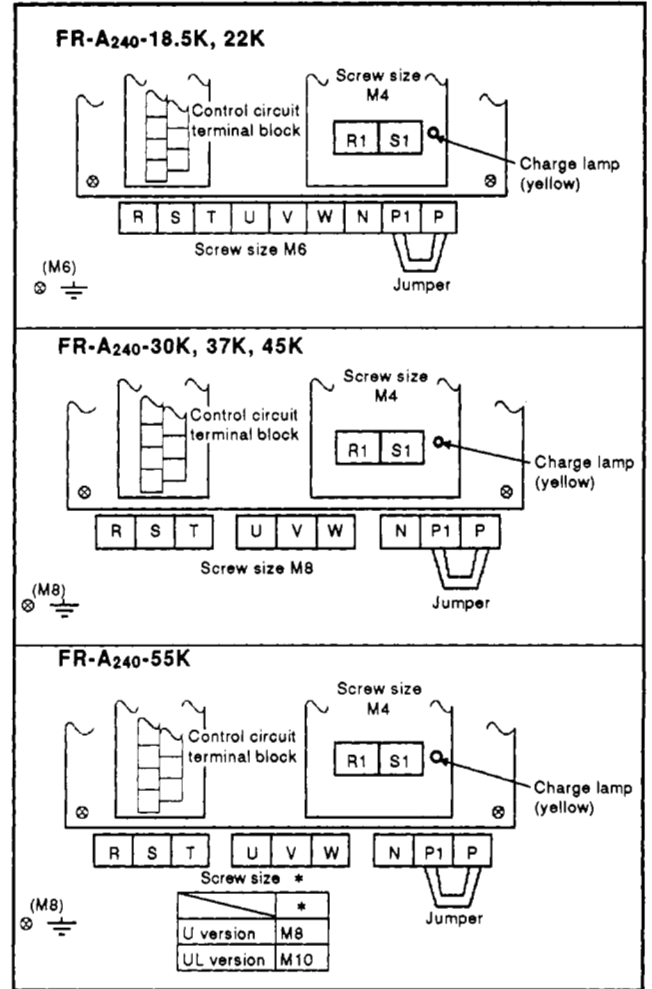
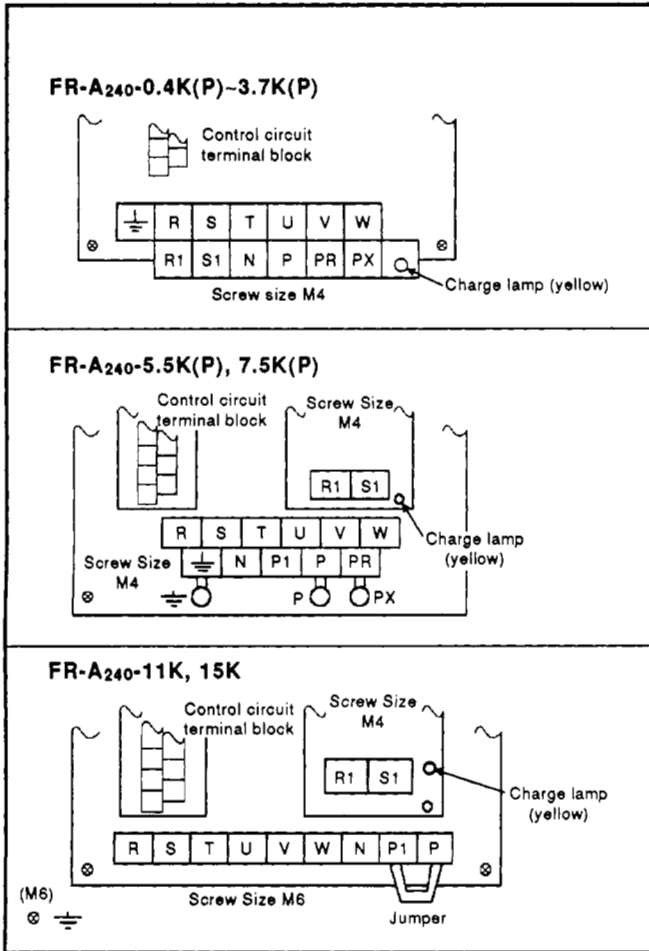

10. SPECIFICATIONS

Field wiring reference table for input (R,S,T) and output (U,V,W)

Note (*1) Manufacturer : AMP INCORPORATED, HARRISBURG, PA 17105
PHONE : 717-564-0100 TWX : 510-657-4110

(*2) Use copper wire only

Invertre model	Screw size	Screw torque (Pound inch)	Crimping terminals Type and tool type (*1)		Wire size / temp-rating (*2)
			Crimping terminals	Crimping tools	
FR-A220-0.4K -0.75K -1.5K -2.2K	M4	13	32959	47387	AWG14 / 75°C
FR-A220-3.7K	M4	13	32968	59239	AWG10 / 75°C
FR-A220-5.5K	M5	23	320634-0 32543	59239	AWG10 / 75°C
FR-A220-7.5K	M5	23	322128 322048 322002 322154	Hand tool 59974-1 Dies 48752-1	AWG8 / 75°C
FR-A220-11K	M6	40	322051 321670 322155	Hand tool 59974-1 Dies 48753-1	AWG6 / 75°C
FR-A220-15K	M6	40	322053 31811	Hand tool 59974-1 Dies 48754-1	AWG4 / 75°C
FR-A220-18.5K -22K	M8	70	322074 326896	Hand tool 59974-1 Dies 48755-1	AWG2 / 75°C
FR-A220-30K	M8	70	322086	Foot operated power unit 69325-3 Head 69066 Dies 48756-1	AWG1/0 / 75°C
FR-A220-37K	M10	131	322059 322160	Foot operated power unit 69325-3 Head 69066 Dies 48758-1	AWG3/0 / 75°C
FR-A220-45K	M10	131	170740-1	Foot operated power unit 69040 Head 300430 48131 Dies 69065	AWG4/0 / 75°C
FR-A220-55K	M12	219	171500-2	Foot operated power unit 69040 Head 48816 Dies 69060	300MCM / 75°C

10. SPECIFICATIONS

Inverte model	Screw size	Screw torque (Pound inch)	Crimping terminals Type and tool type (*1)		Wire size / temp-rating (*2)
			Crimping terminals	Crimping tools	
FR-A240-0.4K -0.75K -1.5K -2.2K -3.7K	M4	13	32959	47387	AWG14 / 75°C
FR-A240-5.5K -7.5K	M4	13	35787-0 32543-0	59239	AWG10 / 75°C
FR-A240-11K -15K	M6	40	322049 321669 327268	Hand tool 59974-1 Dies 48752-1	AWG8 / 75°C
FR-A240-18.5K -22K	M6	40	322051 322151	Hand tool 59974-1 Dies 48753-1	AWG6 / 75°C
FR-A240-30K	M8	70	322006	Hand tool 59974-1 Dies 48753-1	AWG6 / 75°C
FR-A240-37K -45K	M8	70	322074 326896 322074-0	Hand tool 59974-1 Dies 48755-1	AWG2 / 75°C
FR-A240-55K	M10	131	322087-0 322173-0	Foot operated power unit 69325-3 Head 69066-0 Dies 48757-1	AWG2/0 / 75°C

10. SPECIFICATIONS

10.5 Outline DRAWINGS

- FR-A220- 0.4K(P) , 0.75K(P)

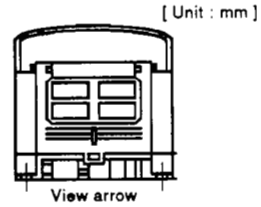
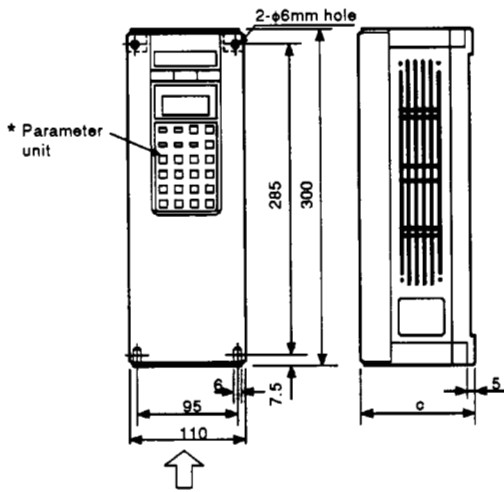

Inverter type	C
FR-A220-0.4K(P)	110
FR-A220-0.75K(P)	125

- FR-A220- 1.5K(P) , 2.2K(P) , 3.7K(P) , 5.5K(P) , 7.5K(P)
- FR-A240- 0.4K(P) , 0.75K(P) , 1.5K(P) , 2.2K(P) , 3.7K(P) , 5.5K(P) , 7.5K(P)

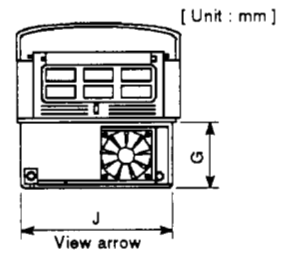
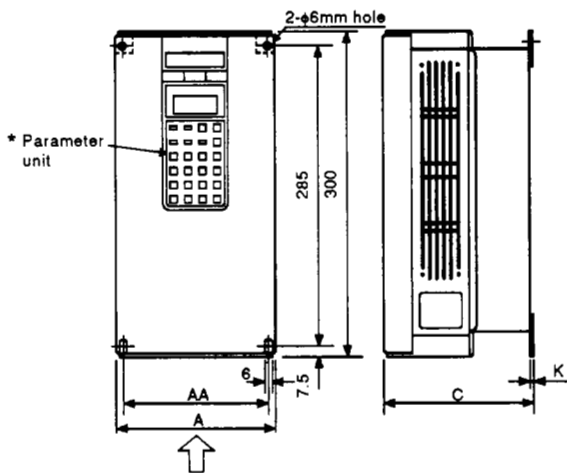

• 200V series

Inverter type	A	AA	C	G	J	K
FR-A220-1.5K(P)	150	125	140	42	142	6
FR-A220-2.2K(P)	150	125	170	76	142	2.3
FR-A220-3.7K(P)	150	125	170	76	142	2.3
FR-A220-5.5K(P)	220	195	190	67	210	2.3
FR-A220-7.5K(P)	220	195	190	67	210	2.3

• 400V series

Inverter type	A	AA	C	G	J	K
FR-A240-0.4K(P)	150	125	170	76	142	2.3
FR-A240-0.75K(P)	150	125	170	76	142	2.3
FR-A240-1.5K(P)	150	125	170	76	142	2.3
FR-A240-2.2K(P)	150	125	170	76	142	2.3
FR-A240-3.7K(P)	150	125	170	76	142	2.3
FR-A240-5.5K(P)	220	195	190	67	210	2.3
FR-A240-7.5K(P)	220	195	190	67	210	2.3

10. SPECIFICATIONS

- FR-A220- 11K , 15K , 18.5K , 22K
- FR-A240- 11K , 15K , 18.5K , 22K

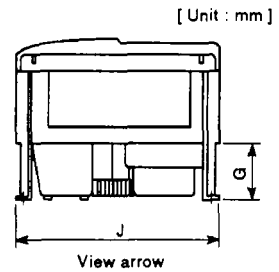
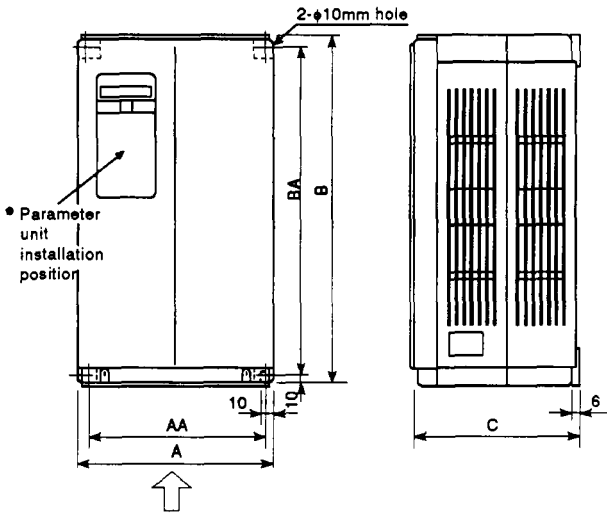

• 200V series

Inverter type	A	AA	B	BA	C	G	J
FR-A220-11K	250	230	400	380	190	80	242
FR-A220-15K	250	230	400	380	190	80	242
FR-A220-18.5K	300	280	450	430	195	80	292
FR-A220-22K	300	280	450	430	195	80	292

• 400V series

Inverter type	A	AA	B	BA	C	G	J
FR-A240-11K	250	230	400	380	190	80	242
FR-A240-15K	250	230	400	380	190	80	242
FR-A240-18.5K	300	280	450	430	195	80	292
FR-A240-22K	300	280	450	430	195	80	292

- FR-A220- 30K , 37K , 45K , 55K
- FR-A240- 30K , 37K , 45K , 55K

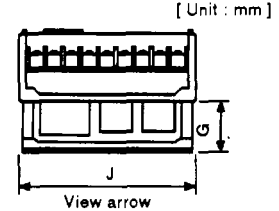
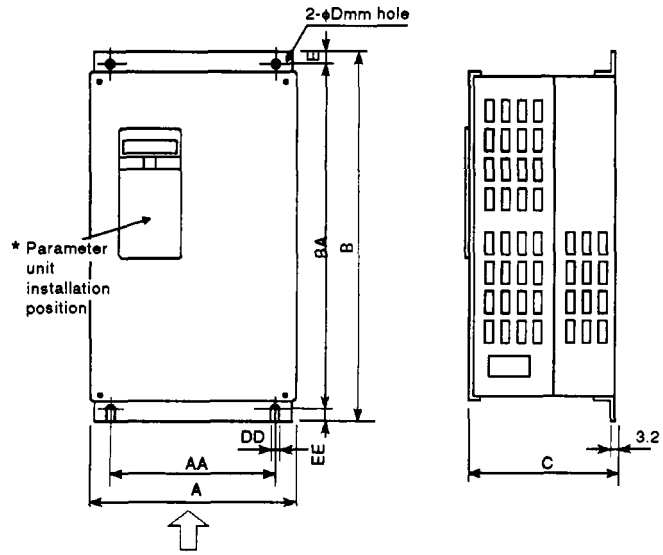

• 200V series

Inverter type	A	AA	B	BA	C	D	DD	E	EE	G	J
FR-A220-30K	340	270	550	530	195	10	10	10	10	78	324
FR-A220-37K	450	380	550	525	250	12	12	15	10	130	434
FR-A220-45K	480	410	700	675	250	12	12	15	10	130	464
FR-A220-55K	480	410	700	675	250	12	12	15	10	130	464

• 400V series

Inverter type	A	AA	B	BA	C	D	DD	E	EE	G	J
FR-A240-30K	450	380	550	525	250	12	12	15	10	130	434
FR-A240-37K	450	380	550	525	250	12	12	15	10	130	434
FR-A240-45K	480	410	700	675	250	12	12	15	10	130	464
FR-A240-55K	480	410	700	675	250	12	12	15	10	130	464

* The 11K to 55K models are not equipped with the parameter unit as standard.

10. SPECIFICATIONS

10.6 FR-PU02(E) Parameter Unit Dimension Diagram

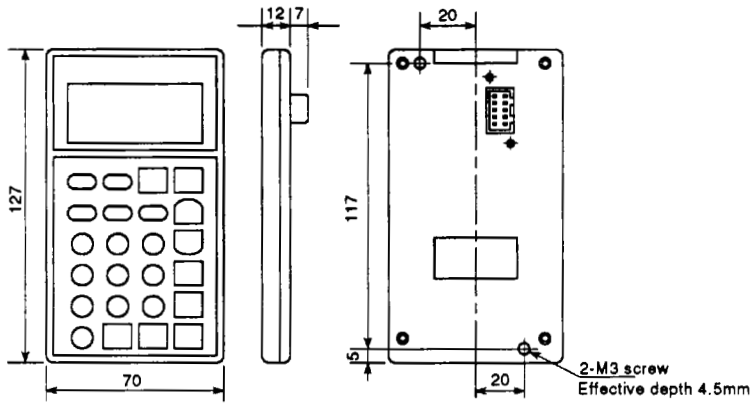

Note: The length of the installation screw should be selected so that it does not exceed the effective installation screw depth of the parameter unit.

Panel cut dimensions for installation of the parameter unit to a panel, etc.

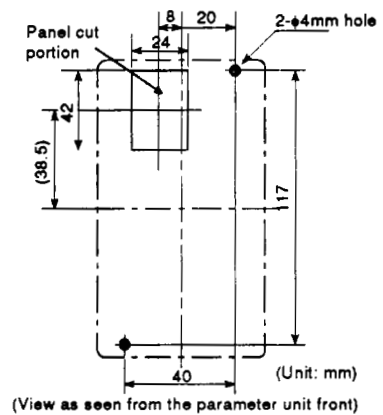

FR-PU02(E)

Item	Specifications	
Ambient temperature	Operating	-10~50°C When the temperature is at less than 0 °C, the liquid crystal display(LCD) may be slower in operation. And high temperature may reduce the LCD life.
	Storage	-20~65°C
Ambient humidity	90%RH max	Non-condensing
Operating ambience	No oil mist and corrosive gases Minimal dust and dirt.	
Connected object	FR-A series inverter or dedicated cable (FR-CBL)	
Power supply	Power is supplied from the inverter.	
Connection	Loaded to the inverter directly or connected by the cable.	
Display	LCD (liquid crystal display, 13 characters x 4 lines)	
Keyboard	24 keys (covered with polyurethane film)	
Size	127 (H) x 70 (W) X 12 (D)	

Note: Do not expose the liquid crystal display directly to the sun.

Do not use any sharp objects on the keypad of the FR-PU02E, or it may damage the membrane.

10. SPECIFICATIONS

10.7 Peripheral Device List

Voltage	Motor Output (kW)	Applicable Inverter Type	Input fuses (note)			Voltage	No-Fuse Breaker (NFB) or Earth Leakage Circuit Breaker (NV)		Magnetic Contactor (MC)	Cables (mm ²)	
			Type	Class	Current (A)		Standard	With power factor improving reactor		R, S, T	U, V, W
200V class	0.4	FR-A220-0.4K	NON-10 (Buss) or OT10 (Gould)	K5	10	250 V AC	Type NF30, NV30 5A	Type NF30, NV30 5A	S-K10	2	2
	0.75	FR-A220-0.75K	NON-20 (Buss) or OT20 (Gould)	K5	20		Type NF30, NV30 10A	Type NF30, NV30 10A	S-K10	2	2
	1.5	FR-A220-1.5K	NON-30 (Buss) or OT30 (Gould)	K5	30		Type NF30, NV30 15A	Type NF30, NV30 15A	S-K10	2	2
	2.2	FR-A220-2.2K	NON-40 (Buss) or OT40 (Gould)	K5	40		Type NF30, NV30 20A	Type NF30, NV30 15A	S-K11, K12	2	2
	3.7	FR-A220-3.7K	NON-60 (Buss) or OT60 (Gould)	K5	60		Type NF30, NV30 30A	Type NF30, NV30 30A	S-K20	3.5	3.5
	5.5	FR-A220-5.5K	NON-90 (Buss) or OT90 (Gould)	K5	90		Type NF50, NV50 50A	Type NF50, NV50 40A	S-K25	5.5	5.5
	7.5	FR-A220-7.5K	NON-125 (Buss) or OT125 (Gould)	K5	125		Type NF100, NV100 60A	Type NF50, NV50 50A	S-K35	14	8
	11	FR-A220-11K	NON-175 (Buss) or OT175 (Gould)	K5	175		Type NF100, NV100 75A	Type NF100, NV100 75A	S-K50	14	14
	15	FR-A220-15K	NON-225 (Buss) or OT225 (Gould)	K5	225		Type NF225, NV225 125A	Type NF100, NV100 100A	S-K65	22	22
	18.5	FR-A220-18.5K	NON-300 (Buss) or OT300 (Gould)	K5	300		Type NF225, NV225 150A	Type NF225, NV225 125A	S-K80	30	30
	22	FR-A220-22K	NON-350 (Buss) or OT350 (Gould)	K5	350		Type NF225, NV225 175A	Type NF225, NV225 150A	S-K95	38	30
	30	FR-A220-30K	NON-450 (Buss) or OT450 (Gould)	K5	450		Type NF225, NV225 225A	Type NF225, NV225 175A	S-K125	60	50
	37	FR-A220-37K	NON-500 (Buss) or OT500 (Gould)	K5	500		Type NF400, NV400 250A	Type NF225, NV225 225A	S-K150	80	80
	45	FR-A220-45K	NON-600 (Buss) or OT600 (Gould)	K5	600		Type NF400, NV400 300A	Type NF400, NV400 300A	S-K180	100	80
	55	FR-A220-55K	NON-600 (Buss) or OT600 (Gould)	K5	600		Type NF400, NV400 400A	Type NF400, NV400 350A	S-K220	150	125
400V class	0.4	FR-A240-0.4K	NOS-5 (Buss) or OTS5 (Gould)	K5	5	600 V AC	Type NF30, NV30 5A	Type NF30, NV30 5A	S-K10	2	2
	0.75	FR-A240-0.75K	NOS-8 (Buss) or OTS8 (Gould)	K5	8		Type NF30, NV30 10A	Type NF30, NV30 10A	S-K10	2	2
	1.5	FR-A240-1.5K	NOS-15 (Buss) or OTS15 (Gould)	K5	15		Type NF30, NV30 10A	Type NF30, NV30 10A	S-K10	2	2
	2.2	FR-A240-2.2K	NOS-20 (Buss) or OTS20 (Gould)	K5	20		Type NF30, NV30 15A	Type NF30, NV30 10A	S-K20	2	2
	3.7	FR-A240-3.7K	NOS-35 (Buss) or OTS35 (Gould)	K5	35		Type NF30, NV30 20A	Type NF30, NV30 15A	S-K20	2	2
	5.5	FR-A240-5.5K	NOS-45 (Buss) or OTS45 (Gould)	K5	45		Type NF30, NV30 30A	Type NF30, NV30 20A	S-K20	3.5	2
	7.5	FR-A240-7.5K	NOS-60 (Buss) or OTS60 (Gould)	K5	60		Type NF30, NV30 30A	Type NF30, NV30 30A	S-K20	3.5	3.5
	11	FR-A240-11K	NOS-90 (Buss) or OTS90 (Gould)	K5	90		Type NF50, NV50 50A	Type NF50, NV50 40A	S-K20	5.5	5.5
	15	FR-A240-15K	NOS-110 (Buss) or OTS110 (Gould)	K5	110		Type NF100, NV100 60A	Type NF50, NV50 50A	S-K25	14	8
	18.5	FR-A240-18.5K	NOS-125 (Buss) or OTS125 (Gould)	K5	125		Type NF100, NV100 75A	Type NF100, NV100 60A	S-K35	14	8
	22	FR-A240-22K	NOS-150 (Buss) or OTS150 (Gould)	K5	150		Type NF100, NV100 100A	Type NF100, NV100 75A	S-K50	22	14
	30	FR-A240-30K	NOS-225 (Buss) or OTS225 (Gould)	K5	225		Type NF225, NV225 125A	Type NF100, NV100 100A	S-K65	22	22
	37	FR-A240-37K	NOS-250 (Buss) or OTS250 (Gould)	K5	250		Type NF225, NV225 150A	Type NF225, NV225 125A	S-K80	30	22
	45	FR-A240-45K	NOS-300 (Buss) or OTS300 (Gould)	K5	300		Type NF225, NV225 175A	Type NF225, NV225 150A	S-K80	38	30
	55	FR-A240-55K	NOS-350 (Buss) or OTS350 (Gould)	K5	350		Type NF225, NV225 200A	Type NF225, NV225 175A	S-K100	50	50

(Note) Use UL recognized fuses.

10. SPECIFICATIONS

10.8 Selecting the Rated Sensitivity Current for the Earth Leakage Circuit Breaker

When using the earth leakage circuit breaker with the inverter circuit, select its rated sensitivity current as follows:

- New Super NV series (Type SF, CF)

Rated sensitivity current: $I\Delta n \geq 10 \times (I_{g1} + I_{g2} + I_{gm})$

- Conventional NV series (Type CA, CS, SS)

Rated sensitivity current: $I\Delta n \geq 10 \times \{I_{g1} + I_{gn} + 3 \times (I_{g2} + I_{gm})\}$

where, I_{g1}, I_{g2} : leakage currents of cable path during commercial power supply operation

I_{gn}^* : leakage current of noise filter on inverter input side

I_{gm} : leakage current of motor during commercial power supply operation

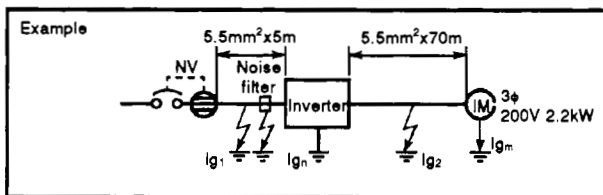

- Note: (1) The NV should be installed to the primary (power supply) side of the inverter.
 (2) Ground fault in the secondary side of the inverter can be detected at the running frequency of 120Hz or lower.
 (3) In the WYE connection neutral point grounded system, the sensitivity current is purified against ground fault in the inverter secondary side. Hence, the protective ground resistance of the load equipment should be 10 Ω or less .
 *For the leakage current value of the noise filter installed on the inverter input side, contact the corresponding filter manufacturer.

Leakage Current Examples of Cable Path When the CV Cable Is Routed in Metal Conduit (200V 60Hz)

Cable Size mm ²	Leakage Current per 1km mA
5.5	33
8	38
14	48
22	50
30	56
38	64
50	64
60	64
100	70

Leakage Current Examples of 3-Phase Induction Motor (200V 60Hz)

Motor Output kW	Leakage Current mA
2.2	0.18
3.7	0.26
5.5	0.29
7.5	0.38
11	0.50
15	0.57
18.5	0.65
22	0.72
30	0.87
37	1.00

Selection Examples (for the diagram shown on the left) (mA)

	New Super NV	Conventional NV
Leakage current I_{g1}	$33 \times \frac{5m}{1000m} = 0.17$	
Leakage current I_{gn}	0 (without noise filter)	
Leakage current I_{g2}	$33 \times \frac{70m}{1000m} = 2.31$	
Motor leakage current I_{gm}	0.18	
Total leakage current I_g	2.66	7.64
Rated sensitivity current ($\geq I_g \times 10$)	30	100

11. APPENDIX

11.1 Countermeasures for Noise

The following countermeasures are available for inverter noise, but the effect will differ greatly according to the type of noise. Refer to the following table and enforce the countermeasures.

- (a) Shield the inverter unit. Store it in a separate panel, or shield it with a metal case and ground the metal case.
- (b) Shield the inverter input/output wire. Use a metal conduit and ground the conduit, or use a shielding wire and ground the shield.
- (c) Install a noise filter on the inverter input side.
 - Radio noise filter (FR-BIF(-H))
 - Line noise filter (FR-BLF)
- (d) Install line noise filter (FR-BLF) on the inverter output side.
- (e) Use twisted pair shielding wire for signal lines.
- (f) Separate the main circuit wire and signal wire or shield with a metal plate.
- (g) Insulate the power supply. Install a insulation transformer or separate the power supply system.
- (h) Lower the inverter carrier frequency. Note that the motor acoustic noise will increase.
- (i) Avoid directly grounding the main unit of the sensor. Remove the grounding or pass through stray capacity.
- (j) Separate the inverter at least 30cm (12 inches) from the other devices.
- (k) Separate the signal wire shield for each circuit.

Effects of countermeasures

No.	Details of countermeasures	Atmospheric noise			Electro-magnetic coupling	Electro-static coupling	Conductive noise	
		Radiated from inverter	Radiated from input wire/grounding wire	Radiated from output wire			Input wire	Grounding wire
(a)	Shield inverter unit	◎	×	×	×	×	×	×
(b)	Shield input/output wire	×	◎	◎	○	○	×	×
(c)	Noise filter on input side	×	◎	×	△	△	◎	×
(d)	Noise filter on output side	×	×	◎	△	△	×	×
(e)	Twisted pair shielding wire	○	○	○	◎	◎	×	×
(f)	Separate main circuit and signal wire	○	○	○	◎	◎	×	×
(g)	Insulate power supply	×	×	×	×	×	◎	△
(h)	Lower carrier frequency	◎	◎	◎	○	○	◎	◎
(i)	Avoid direct grounding of sensor	×	×	×	×	×	○	◎
(j)	Separate inverter circuit	○	◎	◎	◎	◎	×	×
(k)	Separate signal wire shield	×	×	×	△	△	△	◎

Meaning of symbols.....

◎ : Very effective ○ : Effective × : Not very effective

11. APPENDIX

Types of noise

The following types of noise occur according to how the noise is conducted.

- | | |
|--|--------|
| 1. Atmospheric emission | Route |
| 1) Noise radiated from inverter..... | (1) |
| 2) Noise radiated from input wire/grounding wire | (2) |
| 3) Noise radiated from output wire | (3) |
| 2. Electromagnetic coupling | (4)(5) |
| 3. Electrostatic coupling | (6) |
| 4. Conductive noise | |
| 1) Noise that conducts through input wires | (7) |
| 2) Noise that comes in from grounding wires | (8) |

Route of noise spreading

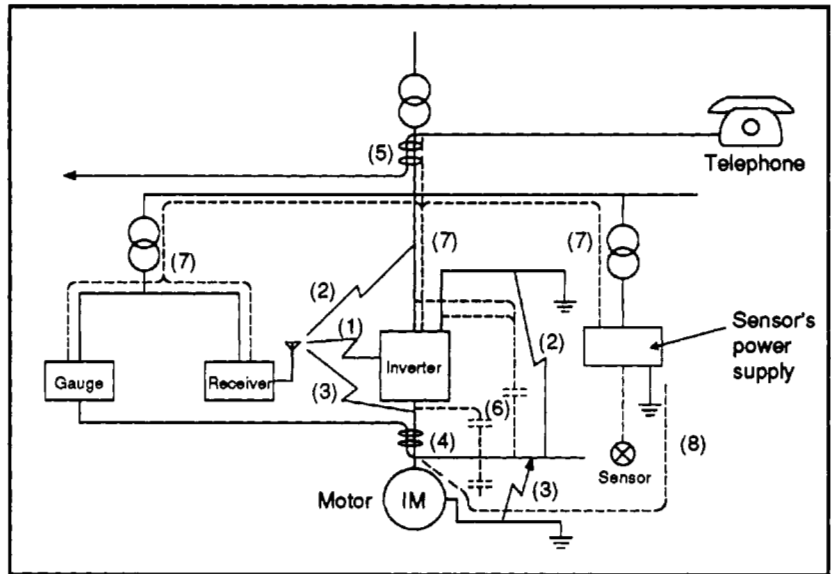

11.2 Leakage currents

The inverter and the motor must be grounded securely using their ground terminals to prevent an electric shock due to earth leakage. Any accident due to the leakage current is not covered by our warranty.

Where grounding is difficult or for larger grounding resistance, grounding accident, deteriorated insulation, portable motor-operated machine, etc., the earth leakage circuit breaker (ELCB) should be installed to protect personnel from electric shock.

But the ELCB may operate unnecessarily when used with the PWM inverter, because the inverter output voltage changes instantaneously, high harmonic leakage currents flow due to the earth stray capacity and the ELCB might respond to harmonic leakage current. Generally, the higher sensitivity the ELCB rating is, the more often the ELCB operates unnecessarily.

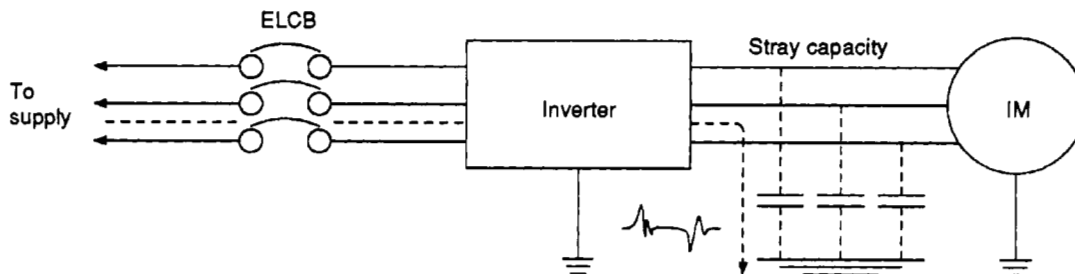

High harmonic leakage currents due to stray capacity

For selecting the rated sensitivity current of the ELCB, refer to section 10.8.

11. APPENDIX

Countermeasures for unnecessary operation of earth leakage circuit breaker

Use an earth leakage circuit breaker that considers high harmonic components. It has been developed to be used with an inverter, such as the Mitsubishi New Super NV series, which is equal in sensitivity current to 60 Hz and is larger in sensitivity current to the harmonics as compared to the conventional ELCBs.

Countermeasures for malfunctioning of thermal relay

Install a reactor (FR-BOL) on the inverter output side.

By using FR-BOL, the impedance is increased and the leakage current between the wires is decreased.

Use an electronic thermal relay built in inverter.

The electronic thermal relay cuts the high frequency before detection so it is not easily affected by the leakage current.

Increase the setting value of the external thermal relay.

If an electronic thermal relay cannot be used due to installing separate thermal relays for each motor when using two or more motors with one inverter, etc., increase the external thermal setting value by the amount of the leakage current, to suppress operation.

If the motor capacity exceeds 11 kW, the rated current will be large so the effect of the leakage current will not be a big problem.

Effects of countermeasures

The countermeasures marked with a ☉ are recommended for each phenomenon caused by the leakage current.

Phenomenon	(a) New Super NV	(b) Install reactor on output side.	(c) Use electronic thermal relay.	(d) Increase thermal relay setting.	(e) Lower carrier frequency.	(f) Use shortest wiring length
Leakage breaker in same line operates.	☉	×	×	×	☉	○
Leakage breaker in different line operates.	☉	×	×	×	☉	○
Thermal relay operates.	×	○	○	○	☉	○

Meaning of symbols.....

☉ : Very effective ○: Effective ×: Not very effective

REVISIONS

* The manual number is given on the bottom left of the back cover.

Print Date	*Manual Number	Revision
May, 1993	IB (NA) 66430-A	First edition
Feb, 1994	IB (NA) 66430-B	Addition of Overload Protection (page 11) and Field wiring reference table (page 108,109) and Short Circuit Rating (page 102). Revision of Factory Setting of Pr 58 (page 53) Revision of Coasting Time for Pr57=0 (page 65)



MITSUBISHI ELECTRIC CORPORATION

HEAD OFFICE: MITSUBISHI DENKI BLDG MARUNOUCHI TOKYO 100