



the standard in safety

## **International Photovoltaic Reliability Workshop II**

# **PV Fire: Experience and Studies**

**Liang Ji**

**Underwriters Laboratories Inc (UL)**

**July 31, 2009**

**Tempe, Arizona, USA**

# PV Fire Study

**There are two major considerations for fire safety of photovoltaic systems:**

- 1. Fires caused by PV components and systems**
- 2. Fires caused by external sources**

# PV Arcing - 1

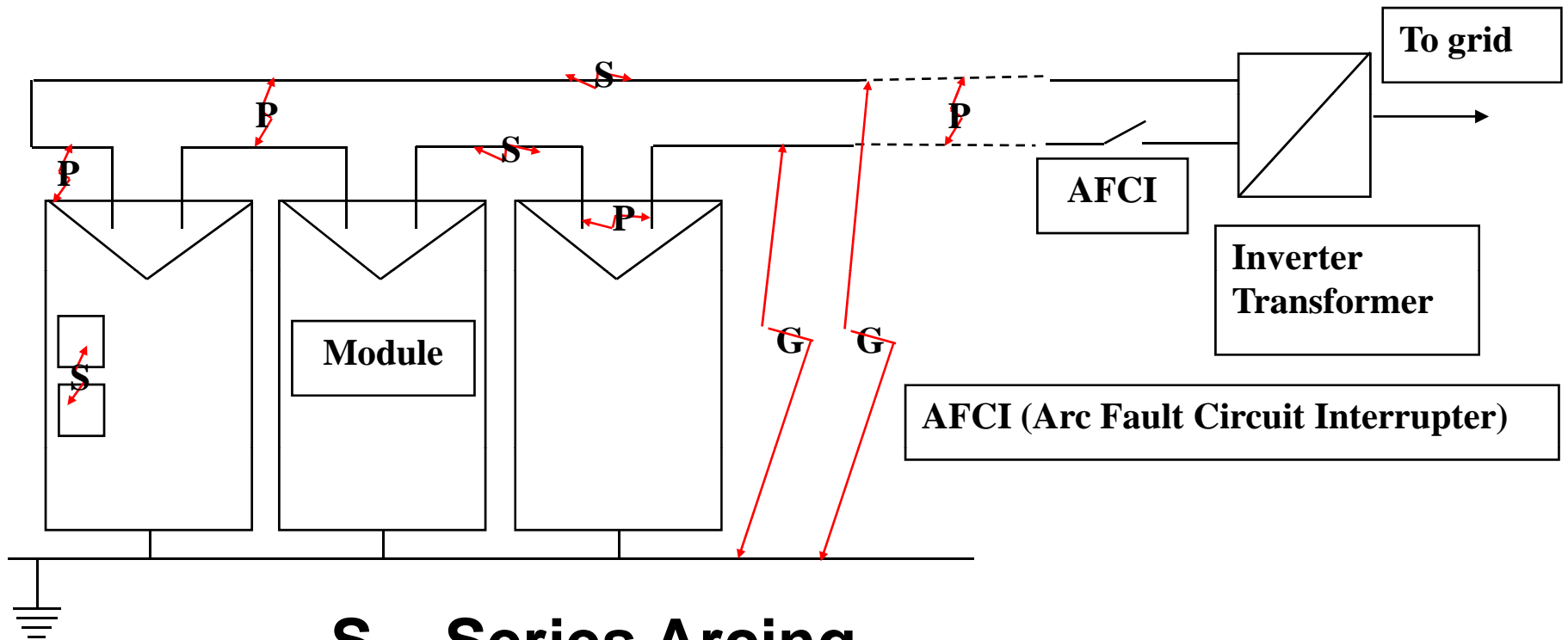

**S – Series Arcing**  
**P – Parallel Arcing**  
**G – Grounding Arcing**

# PV Arcing - 2

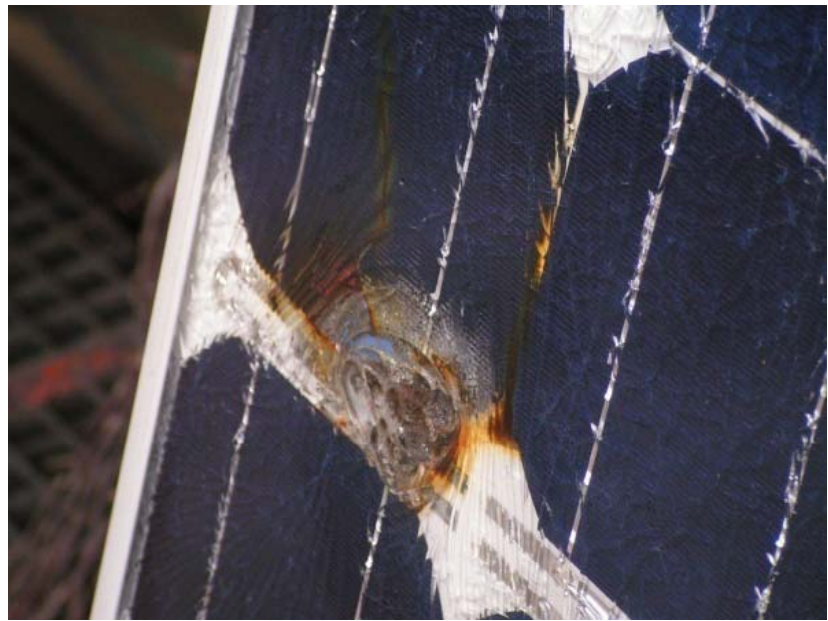

**Simulation test at UL on 1/24/2007**

# PV Arcing - 3

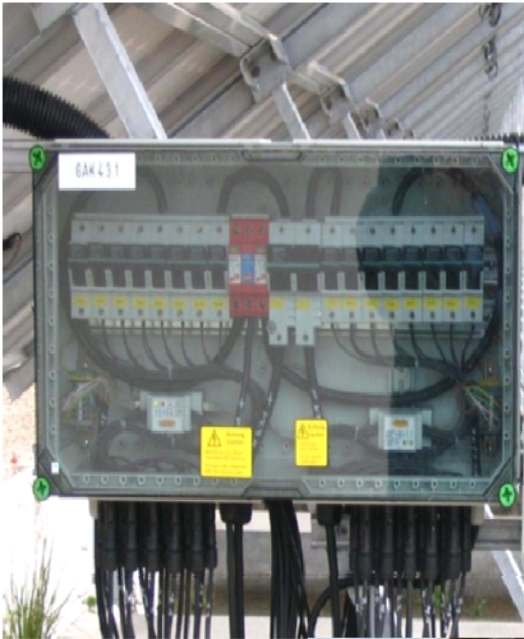

Photo from: Peter Kremer, VDE and DIN

# Parallel Arcing

- Parallel arcing is caused by a short between positive and negative wires.
- It is considered as a double-failure, therefore; has not received high priority now.



The middle two bus bars could cause a parallel arcing – the spacing is too close.

# Testing for Arcing...Needs

- **Developing new test methods related to arcing caused by PV modules, balance of system (BOS) and system installations.**
- **Improving requirements for PV module polymeric materials to minimize spread of fire, if an arcing occurs.**

# AFCI Research

Under the support of **SAI** (**S**olar **A**merica **I**nitiative), **SolarABCs** (The **S**olar **A**merica **B**oard for **C**odes and **S**tandards)

<http://www.solarabcs.org/>

UL is conducting a PV **AFCI** (**A**rc **F**ault **C**ircuit **I**nterrupter) research to develop correspondent requirements (not the product design or product itself).

It may be added to NEC 2011. **NEC** (**N**ational **E**lectrical **C**ode), update every 3 years.



# PV Arc and Fire 2/10/2009



**Before the fire**

# PV Arc and Fire 2/10/2009



# Two Other PV Fires

## **BIPV Fire 3/8/2009**

**It shows that with some BIPV installations, partial shading is “normal operation condition”, twice or more everyday**

## **PV Arc and Fire 4/5/2009**

**Installation could cause a big problem. In this situation, the long conduit slipped out from the joint, and cut the wires' insulation inside, caused a big arc**

# IEC/UL PV Module Fire Test

**Fire test on following standards are similar:**

- **IEC 61730-2:2004 Photovoltaic (PV) module safety qualification – Part 2: Requirements for testing**  
**Clause 10.8 Fire test MST 23**
- **ANSI/UL 1703-2004 (R2008) Flat-Plate Photovoltaic Modules and Panels**  
**Section 31 Fire Tests**
- **ANSI/UL 790-2004 (R2008) Standard Test Methods for Fire Tests of Roof Coverings**  
**Section 7 Spread-of-Flame Test**  
**Section 8 Burning-Brand Test**

# IEC/UL PV Module Fire Test

Parameter	Class A	Class B	Class C
Pitch of PV Modules	22.6° (or per manufacturer if it > 22.6°)		
Min. Module Width (m)	1.0		
Min. Module Length (m)	1.8	2.4	3.9
Wind speeds (m/s)	5.3		
<b>Spread-of-Flame Test</b>			
Flame Temperature (°C)	760	760	704
Test Duration (min)	10	10	4
<b>Burning-Brand Test</b>			
Brand type	kiln-dried Douglas fir lumber free from knots and pitch pockets		
Brand Size (mm)	300X300X57	150X150X57	38.1X38.1X19.8
Number of Brands	1	2	20

# European Fire Test

For the external fire performance of roofs, a harmonized classification system and related test methods have not been introduced so far.

**All tests are acceptable for CE mark.**

Parameter	Test 1	Test 2	Test 3	Test 4
Original standard	DIN	NORD	AFNOR	BS
Country	Germany	Nordic Countries *	France	UK
Specimen size (m)	0.8 x 1.8	0.4 x 1.0	1.2 x 3.0	0.84 x 0.84
Pitch of test specimen	15° or 45°	30°	5° or 30°	45° or horizontal
Brand type	wood wool in basket	wood crib	fiber board brands	gas flame
Wind speeds (m/s)	not specified	2	2 and 4	6.7
Radiation levels	not applied radiation	not applied radiation	12.5 kW/m <sup>2</sup>	12.5 kW/m <sup>2</sup>

# Fire Test Comparison

**Comparing previous two tables, we can see, the test methods and requirements different.**

**There are differences of opinions on which one is more severe, or if one test can substitute for the other. Also, which fire test methods are most relevant for different fire scenarios?**

**One thing is clear:**

**We need “national differences” .**

# IEC/UL Spread of Flame Test

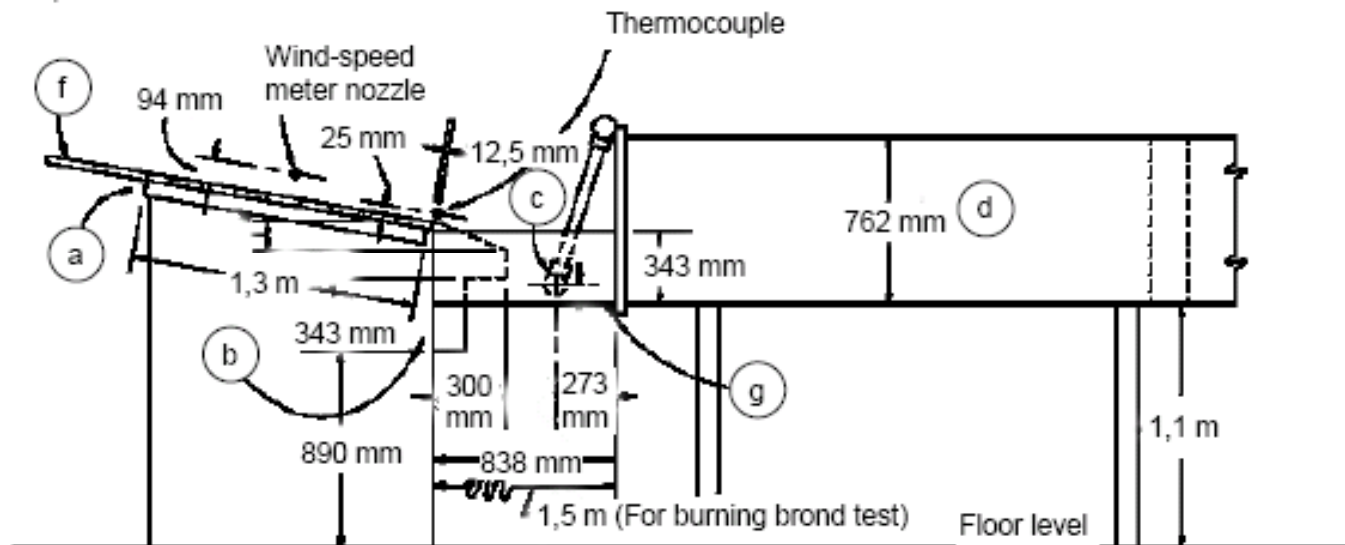

Side view



# IEC/UL Burning Brand Test

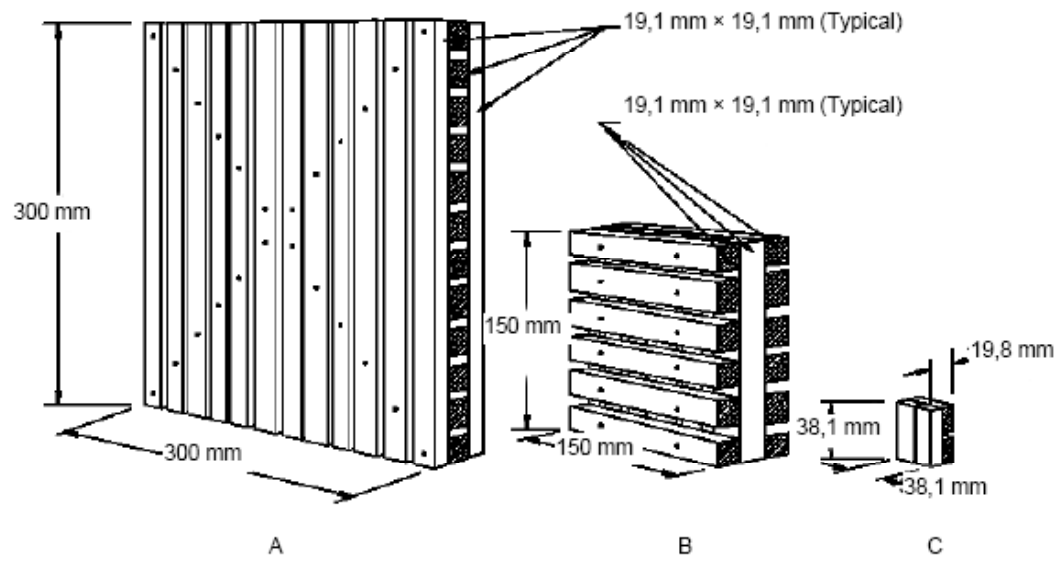
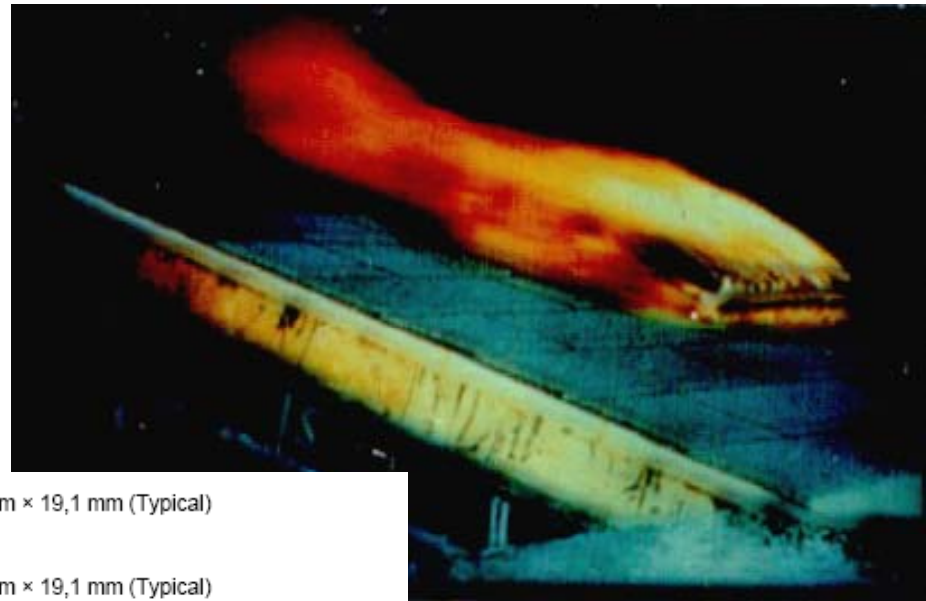

# SAI PV Fire Research - 1

Under the support of **SAI** (**S**olar **A**merica Initiative), **SolarABCs** (The **S**olar **A**merica Board for **C**odes and **S**tandards)

<http://www.solarabcs.org>

**UL is conducting fire test simulations to determine if and how PV modules affect roofing materials in the event of building fires.**

# SAI PV Fire Research - 2

**As a result of catastrophic fires in California, the State Fire Officials are preparing to implement a statewide requirement for Class A fire rating of all roofing products.**

**They have been considering requiring that all PV modules obtain Class A rating as well.**

**However to-date, there are few Class A rated PV modules or BIPV products, out of hundreds of listed PV modules.**

# SAI PV Fire Research - 3

**This new UL PV Fire Research Project will:**

- **provide critically needed test data to develop the appropriate requirements;**
- **answer pertinent industry questions and issues associated with the use of PV modules over Fire-Class rated roofing materials.**

# SAI PV Fire Research - 4

**The research will have several phases:**

- 1. study the interaction of the panel and the roof during fire tests (gap heights, leading edges);**
- 2. study different combinations of PV modules and roofing materials  
(Class C PV module + Class A roof = ?).**

**For latest information and result:**

**<http://www.solarabcs.org>**

# **Thanks!**

## **Contact Information**

**Liang Ji**

**Underwriters Laboratories Inc (UL)**

**Email: <liang.ji@us.ul.com>**