

A BlueStar Theory: The New 12 Centered Human (The fusion of Kyron's 12 Centers of DNA and the evolving model of Human Design)

In her fascinating book "The New Human" by Mary Rodwell [2016], the case is made by Mary that the New Humans are *"new generations of children and young adults [that are] consciously and intimately connected to galactic intelligences. They contend that they have come from star origins to bring about change and spread the truth of who we really are."* Mary's assertion is that humans are evolving to be more multi-dimensional, more aware of their ancient history and their connection to both the planet, the stars, and to the understanding that we are perhaps one of many intelligences spread throughout the Universe.

Information from this evolutionary situation come in Information Pulses. These Information Pulses are received by beings on Earth and translated based on their understanding and intuition into new sources of discovery. Mary's writing is a new book from the Wave 2 Information Pulse of discussions regarding human evolution. The New Human is the next energy wave of evolution that followed the Wave 1 Information Pulse of discussions, with books such as "The Indigo Children" by Lee Carroll and Jan Tober [1999], or the concepts of Human Design as created by Ra Uru Hu in 1989.

Each information wave pulse plants the seeds of Awareness that we are more connected to the Earth and the Stars than we realized. Each pulse also works to undo the significant damage that was done to the collective psyche from works such as the "War of the Worlds" radio drama by Orson Welles in 1938. Not all stellar entities are benevolent and not all are hostile, just as most of the people on this planet are not purely benevolent or hostile. Each works according to its design and the agenda of its evolution. Another part of the Wave 1 Pulse are the works of Kyron as channeled by Lee Carroll. This work bridges and

directly contributes to the Wave 2 Pulse as we will see later in this discussion.

Part of this Wave 1 Pulse was the revolutionary work by Alan Krakower who evolved into Ra Uru Hu during a transformative experience in 1987. This transformative experience resulted from a heavy outpouring of neutrinos from the Supernova 1987a in the Large Magellanic Cloud. (A neutrino is a neutral subatomic particle with a very small mass that is generated by stars, the Breath of Stars). The result of this energetic transformation was the creation of a new system of human understanding called Human Design. Human Design combines the theories of astrology, the Vedic chakras, I'Ching, the Judaic Kabbalah, genetics, and modern science to determine someone's Design. This Design is how an individual interprets information from and projects information to the world around them.

As an oversimplified example, as astrology would denote someone as a Taurus, Human Design would classify the person as an Earth-type Taurus with X centers defined and Y centers undefined, following general themes or keynotes throughout this incarnation, based on one of four configurations as a method of interaction. We know that one Taurus isn't like all other Taurii, and Human Design allows us to understand our way of being at the individual level, instead of at the group level. Each of us is unique, and because of that uniqueness, each of us is valuable.

It is a very complicated system, and it takes years of study to understand. The value of Human Design is that it gives us a great new understanding of 'Who We Are' and 'Why We Operate In The Manner In Which We Do' as individuals, and how we interface with and within groups. The development of Human Design was a truly evolutionary step as a Wave 1 Pulse.

One of the key components of the Human Design system is the number of body centers. Evolution can be thought of in some cases as the

number of chakras or body centers that we have. As life has evolved on the planet, the number of body energy centers increased. Currently, the Human Design platform is for a nine-centered being. A picture exists below of this nine-centered configuration..

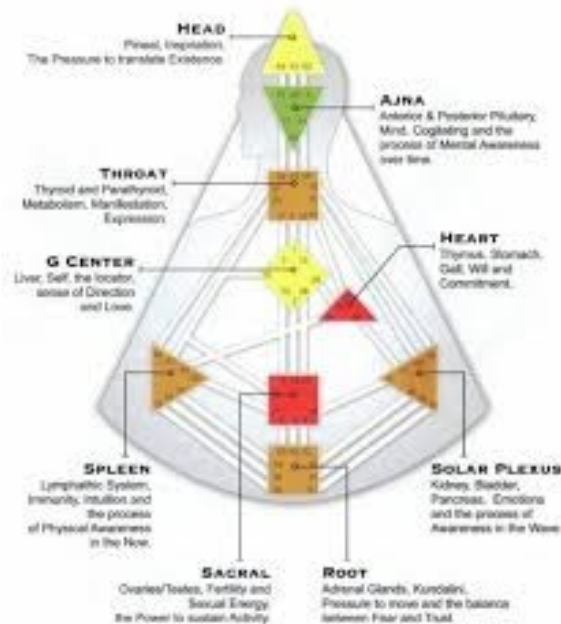

I would suggest that the centers can be numbered grouped in the following way based on the way that we evolved:

- 1.1 Spleen – body consciousness, instinct, survival
- 1.2 Sacral – vitality, sexuality, persistence
- 1.3 G / Identity – love, direction, identity

- 2.0 Throat – manifestation and communication
- 3.0 Root – stress pressure, adaptation

- 4.1. Heart / Ego – ego and willpower, self-worth
- 4.2. Head – mental pressure (like the memory in a computer)
- 5.1. Ajna – mental awareness (like the processor in a computer)
- 5.2. Solar Plexus – emotions, moods, sensitivities, spirituality

Note that within the current nine centers, some centers may be colored (defined) or not-colored (undefined). In general, defined centers can be considered information transmitters and undefined centers can be considered information receivers. This can be observed in the example below.

The Human Design System The User Manual for Your Life

Ryk Hall's rave bodygraph

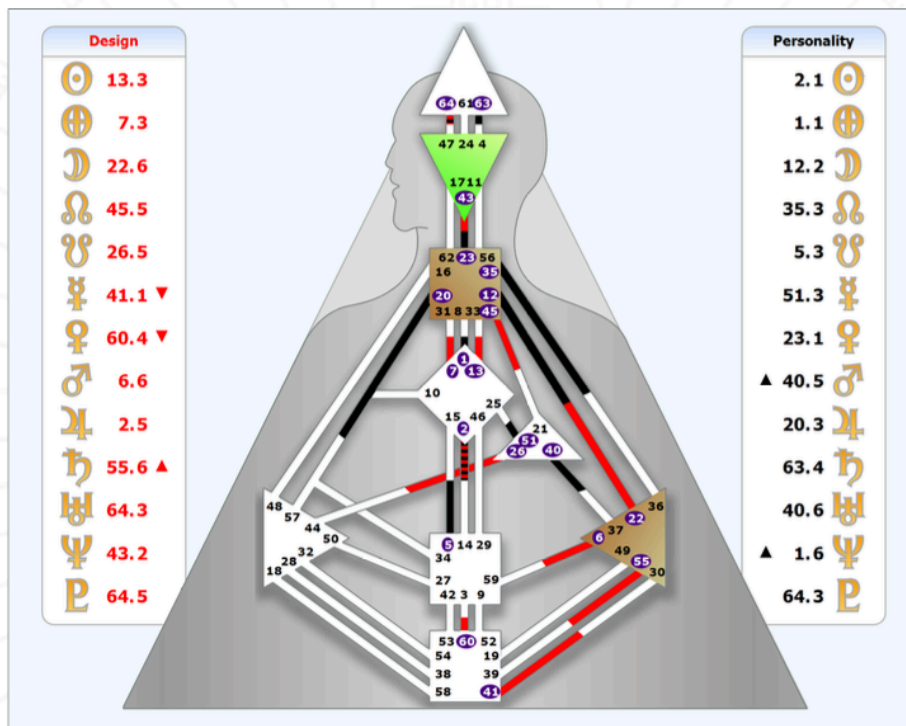

Type: Manifestor
 Aura: Closed and Repelling
 Strategy: Inform Before Acting
 Authority: Emotional - Solar Plexus
 Profile: 1-3 Investigator/Martyr
 Definition: Single Definition
 Not-Self: Anger
 Signature: Peace
 Incarnation Cross: Right Angle Cross of the Sphinx 2

Notice in this next example that the Ajna - Throat - Solar Plexus are defined (transmitters), and the Head - G - Heart - Spleen - Sacral - Root centers are undefined (receivers). The lines (also known as channels) and gates (numbers on each center) are beyond the scope of this discussion.

EVOLUTION

Various configurations of the Human Design body centers have been prevalent throughout evolution. Not all body centers have existed at the same time. One can start with a Core of the Spleen - Sacral - G, and then add centers on for each major evolution. We can walk through these general evolutionary configurations as seen below.

PLANTS (3 Centers): The first group are the plants. Plants are a three-centered being with the [G / Spleen / Sacral] centers defined. Please note that the other centers aren't undefined - they simply don't exist. Plants are strong in their identity, their survival, and their reproduction / sexuality. Under current evolution theory, land plants began around 850 million years ago in the Proterozoic Period.

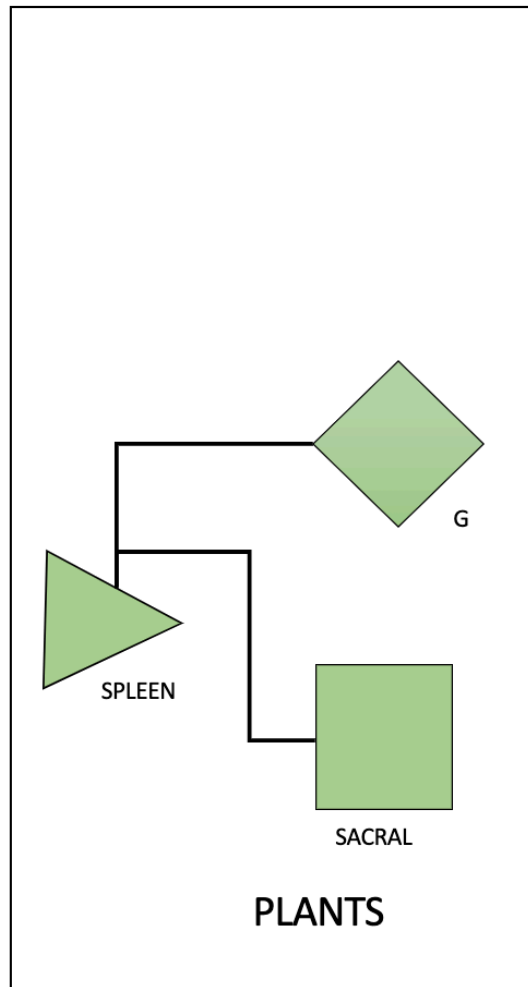

INSECTS (4 Centers): The next group are the insects which are a four-centered being. The insects take the basic plant configuration and add a [Throat Center] so that they can communicate with the world. Insects began approximately 400 million years ago in the Early Devonian Period.

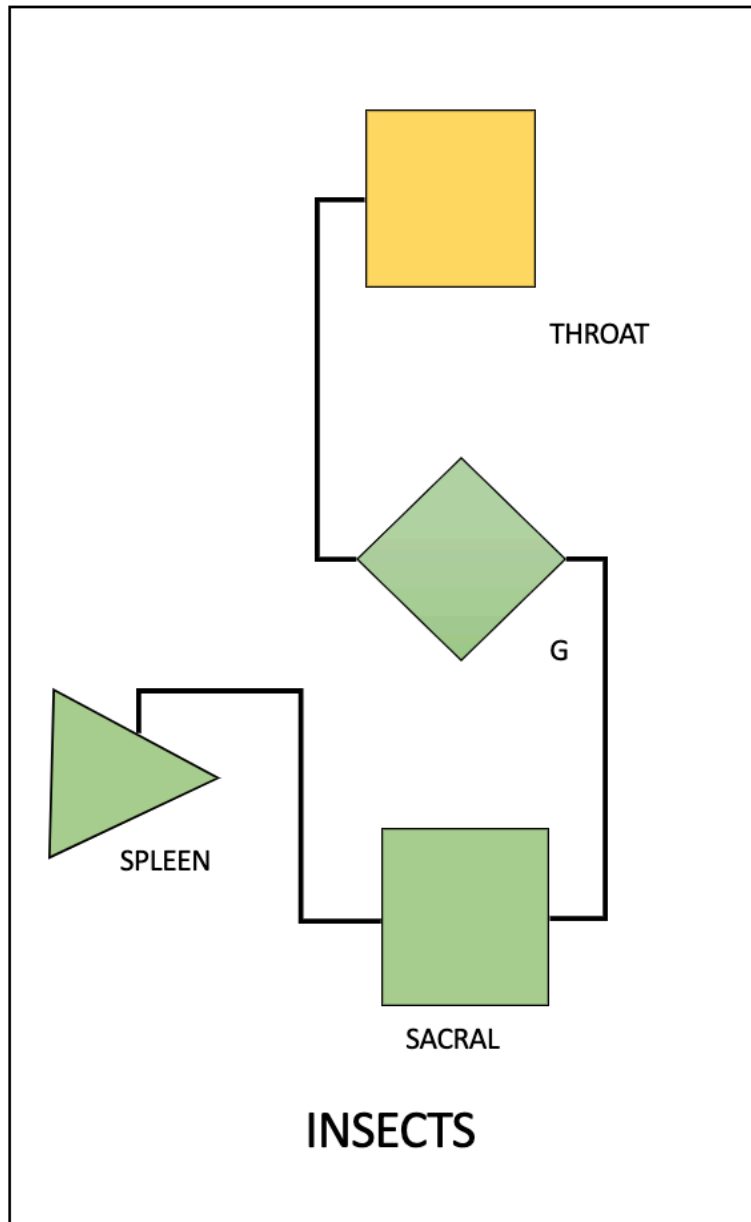

FISH REPTILES BIRDS (4 Centers): Fish and Reptiles were the next major groups to evolve, followed by Birds. They are also four-centered beings with the same centers as insects, but the [Throat Center] is more directly tied to the [Identity Center]. Reptiles arose around 300 million years ago during the Carboniferous period.

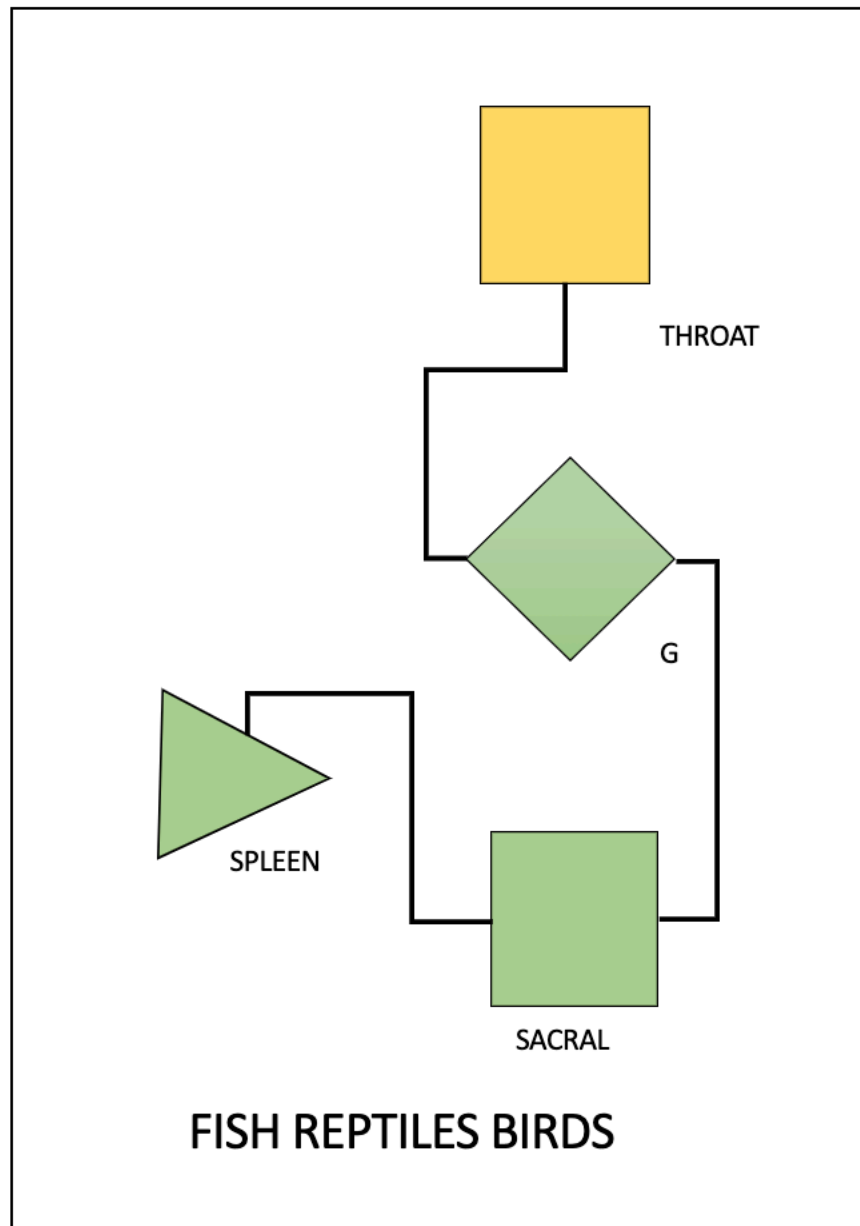

MAMMALS (5 Centers): Mammals represent the next evolutionary addition of a body center by way of the [Root Center] addition, and thus became a five-centered being. Mammals were more adaptable to their environment and were capable of being more tolerant of habitat extremes on the planet. This drove the development of the [Root Center] to manage the pressure and stress that these habitats generated. Mammals evolved approximately 200 million years ago.

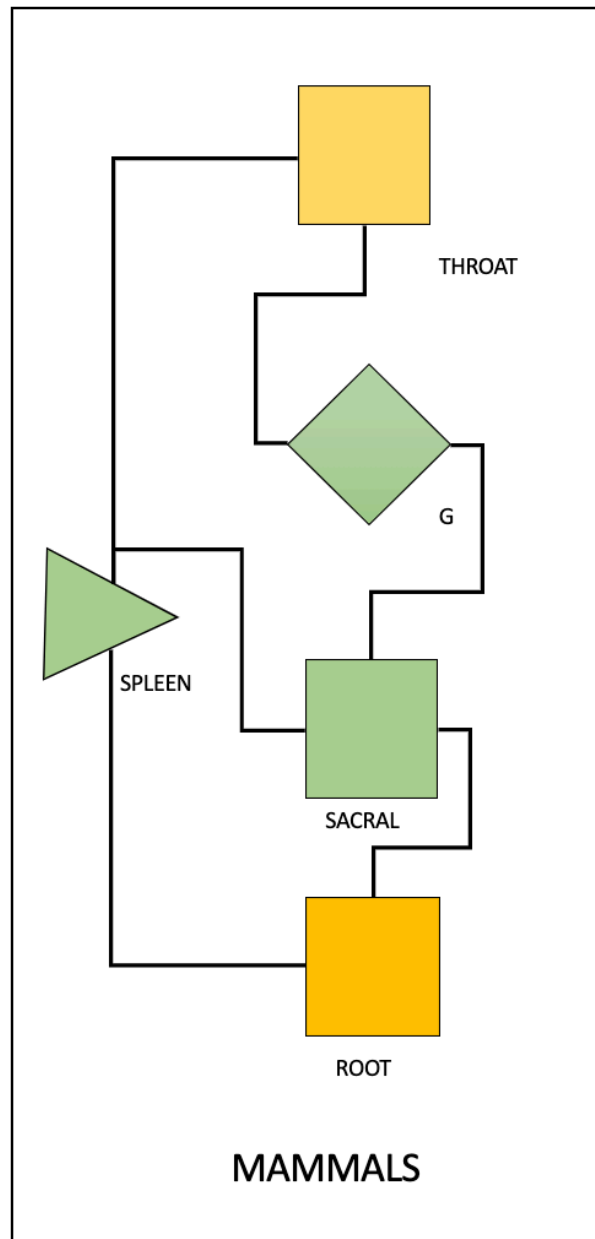

MODERN HUMANS v1 (7 Centers): This image below can be referenced for the next discussion. Approximately 300 thousand years ago modern humans arose on the planet. These are called the AMH or Anatomically Modern Humans because they had remarkable differences from previous humans such as 23 chromosomes, a larger brain size, and thinner bones. The 'missing link' between older species

and AMH has not been found as of the date of this writing. It is as though the AMH or Modern Humans v1 just appeared.

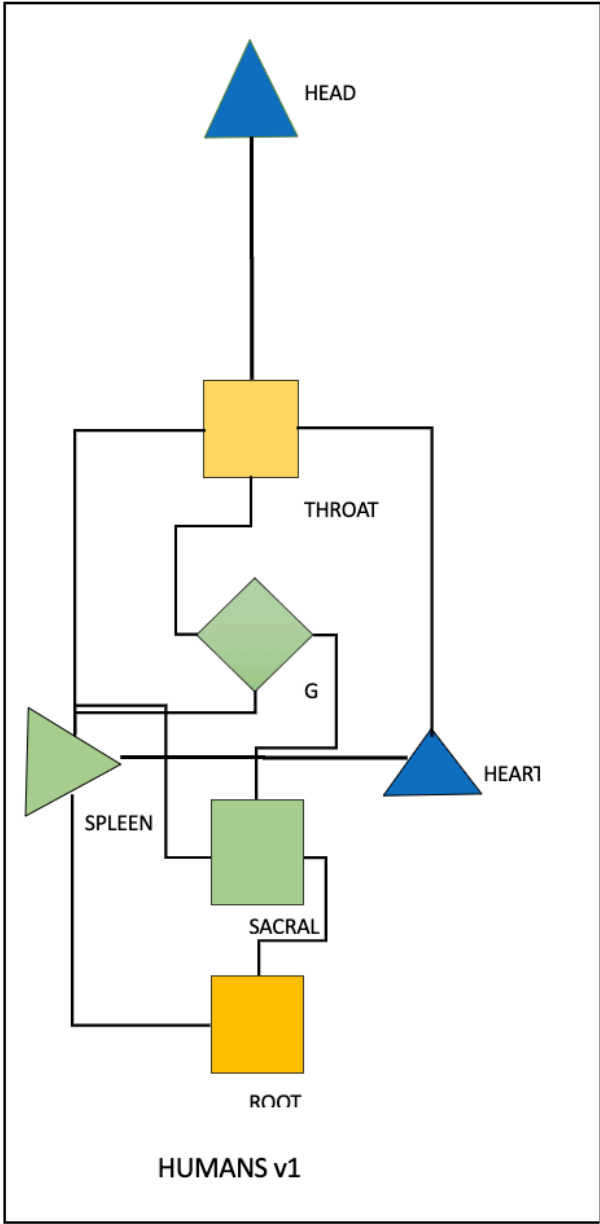

The v1 humans were a seven-centered design. The v1 humans took the five-centered design of the mammal which contained the [Root - Spleen - Sacral - G - Throat] centers and added the centers for the [Heart & Head]. Thus more of an identification with self [Ego/Heart] and memory [*Head*] was included with the v1 humans.

MODERN HUMANS v2 (8 Centers). About 80 thousand years ago, the design of humans was tweaked again. Legend suggests that this design was added by visitors from the Pleiadian star-system (or other systems as well) who raised the Island of Hawaii using a geothermal heat plume and created Lemuria. Of course, it is up to each person to meditate as to whether this legend holds validity for them. Whether the legend resonates with you or not, and whether modern humans evolved with or without aid, it was about this time that the [Ajna] center and the Crystal of Design was added so that we had greater awareness to conceptualize. Previously the human design had only a Crystal of Personality. This addition greatly enhanced our ability to teach future generations and to learn the next step in a process, as well as prepare art and music.

In Human Design theory, the [G] center holds both the Crystal of Personality conscious and the Crystal of Design together. A detailed explanation is beyond the scope of this article.

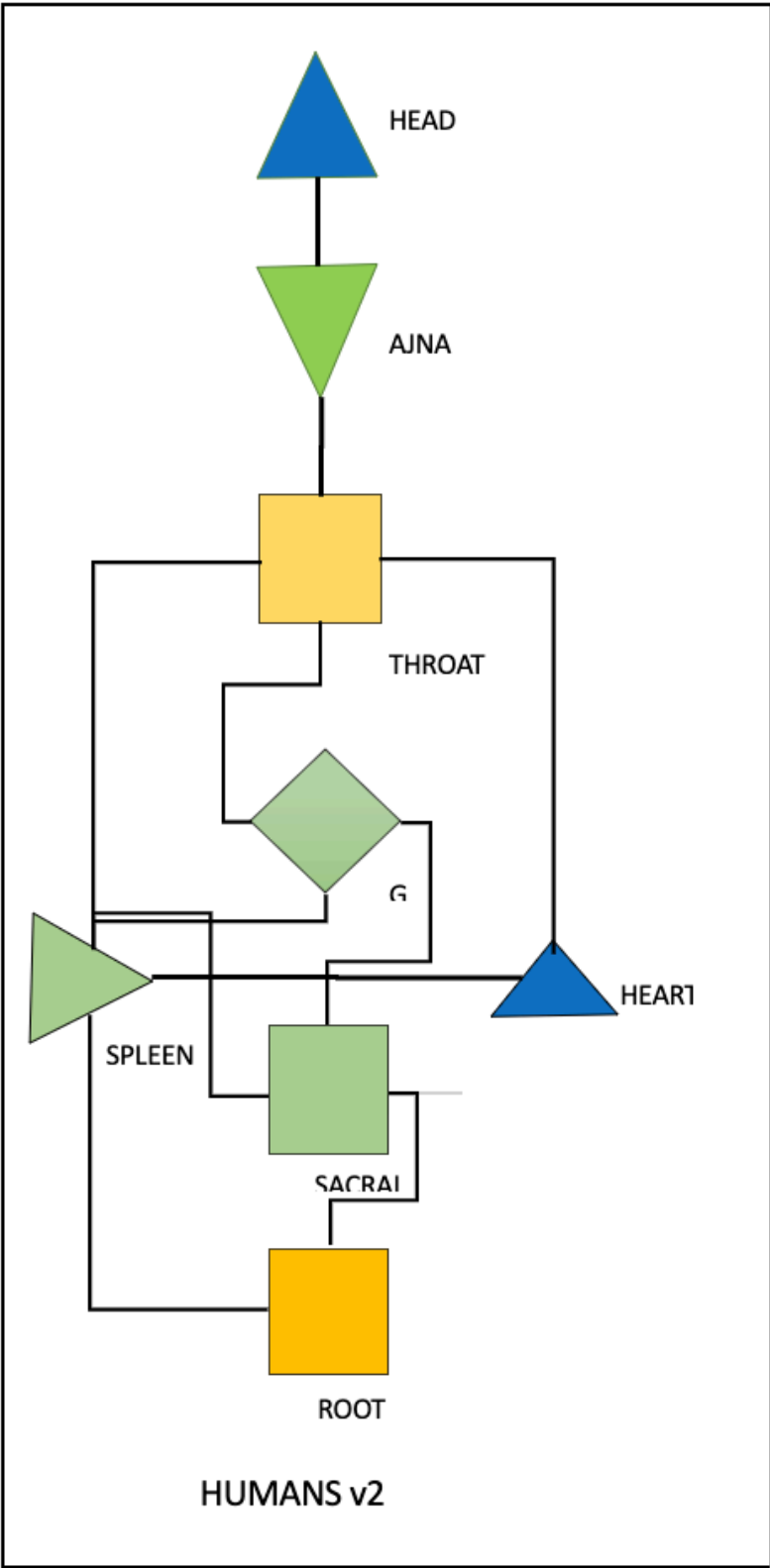

MODERN HUMANS v3 (9 Centers). From about 2,500 to 200 years ago a new a new center developed in humans. This center was the Solar Plexus. This period-of-time has been a very transformative time for humans, beginning with the end of the Vedic period in India, the rise of Buddhism, Christianity, and Islam, the concept of democracy, and ending with the Renaissance in which many forgotten facts were rediscovered, and scientific knowledge took off in leaps and bounds. This was the period of the nine-centered human, focusing on emotional awareness and spiritual concerns.

We have been in a huge transition with this center as the other centers such as the [Heart/Ego] and [G/Identity] Centers try to make room and interface with this new center. One simply has to reflect on how much blood has been spilled over the religious and territorial wars during this period to understand the difficulty in bringing in a new center.

The v3 Human can be viewed in the picture that follows.

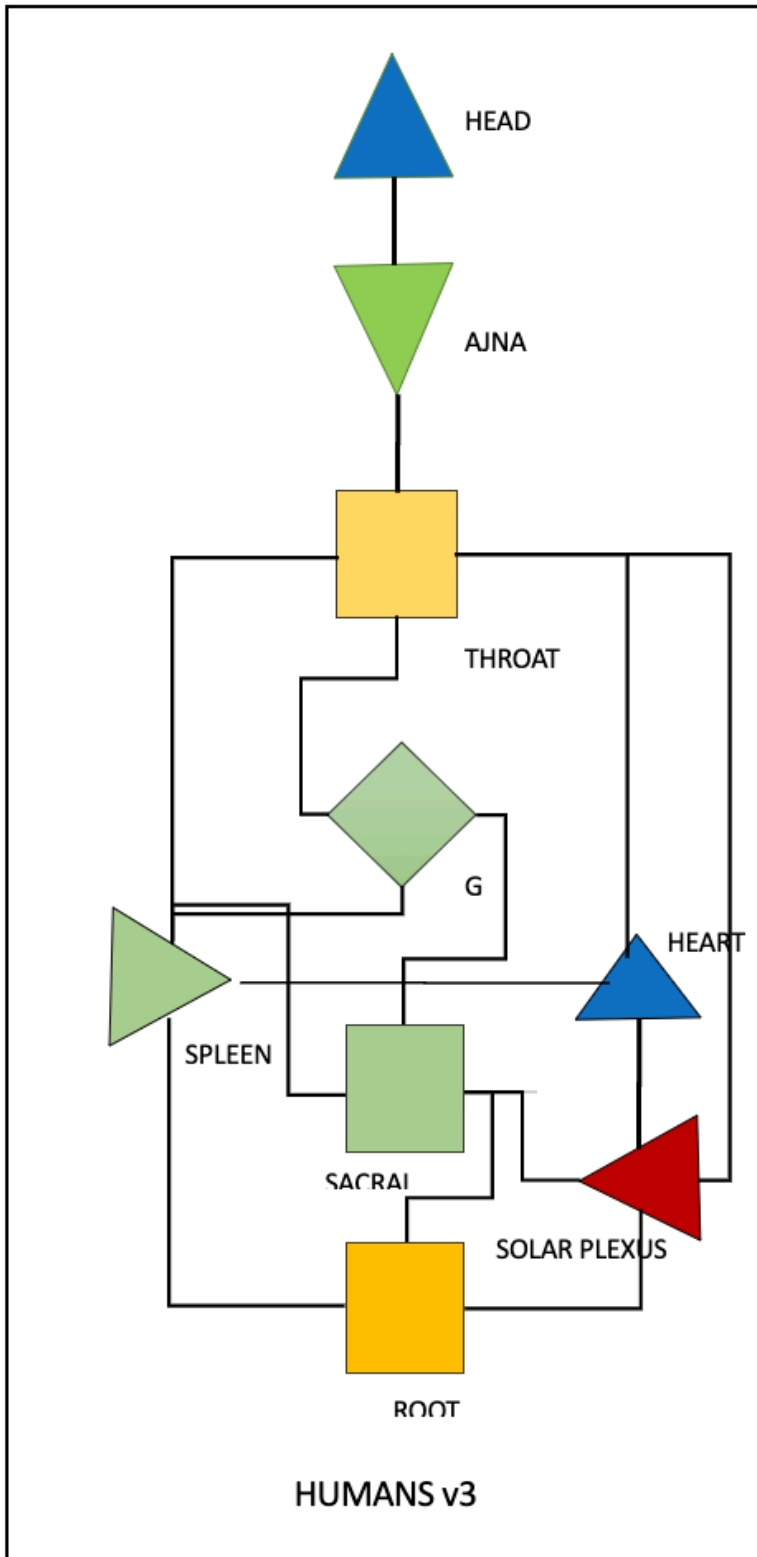

Seeds that were planted in the Wave 1 Pulse are now sprouting in the Wave 2 Pulse. Humans, and the planet Earth, are evolving rapidly. We as the planetary humans made it passed the goal line of 2012. Now further evolution can occur.

THE TWELVE LAYERS OF DNA

In 2010, Lee Carroll released Kyron Book Twelve, "*The Twelve Layers of DNA*". In this book, Lee discusses how DNA is our chemical blueprint. The sequence of DNA bases make up the genetic code. More than that, Lee explains how this DNA interacts with the quantum world. He groups the twelve layers or gates into 4 triads of three gates each.

As the knowledge gained from science evolves, DNA moves from the 3D understanding of chemistry to the metaDNA which involves a metaphysical component. This metaphysical aspect is actualized through the quantum levels. This metaphysical aspect is how humans are evolving to be MDX, the multi-dimensional person.

One of my favorite paragraphs in *The Twelve Layers of DNA* is as follows: *"Let me take you to the interior of DNA itself and reveal to you the esoteric and the love that this process has within it. Far more than chemistry, this DNA event defines the core of sacred life, the love of God within the Universe, mixed with dimensional confluences and the joy of creation. DNA is the crossroads of God and man, the mixture of (the) quantum and non-quantum, and it vibrates with the essence of the truth of the Universe. If you could sit within the double helix and observe all the vibrations as I can, you would be in awe. For within that 3D structure surges the history of the Universe, of mankind, of the seed races and their love for you, and your relationships to the Ages and to*

the Earth. The multidimensional light show is grander than any that any human can conceive, for this is the kind of light that is not seen, but felt. It sings a sonata of melding energies that soothes the soul, and the strains are similar to those you 'hear' when you are on my side of the Veil. For DNA contains the creator energy, your energy, the human transformation energy, and that of all your lifetimes.” [Chapter 6, page 101]

Kryon describes these components to DNA as layers, perhaps visualized more as clouds alternating in different positions than as fixed discrete layers. The key to understanding these layers is to recognize that they are non-linear in nature, and are not linear. Is light a wave or a particle? It is both, as a non-linear phenomena.

The Triads and Layers can be described as follows:

The Triad of Grounding

Layer 01: *The Biological Layer* - this is the only layer that resides in your physical 3D world, but is also multi-dimensional. This is the layer that reacts to the other layers. In Human Design, this layer is related to the [Sacral Center] with the keynotes of vitality and reproduction.

Layer 02: *Your Life Lesson* - although this can be related to your karma, it belongs to your individual core soul; this is completely personal, and only affects you. An example of a Life Lesson is 'learning to speak your truth'. In Human Design, this layer is related to the [G Center] with the keynote of direction.

Layer 03: *Ascension and Activation* - this layer works with the body and the other layers to aid and support spiritual evolution. It is 'listening' for changes in other layers that impact our consciousness. In Human Design, this layer is related to the [Spleen Center] with the keywords of intuitive awareness.

The Triad of the Human - Divine

Layer 04: *Your Personal Guides* - this layer focuses on essence of your expression in this lifetime. Layer 04 is closely interlaced with Layer 05. In Human Design this layer is related to the [Root Center] with the keywords of evolution and drive.

Layer 05: *Your Angelic Name* - this layer is focused on your divinity during this lifetime. Layer 05 is interlaced with Layer 04, as your guides and angels work together. They can be thought of as family. In Human Design this layer is related to the [Throat Center] with the keyword of metamorphosis.

Layer 06: *The Higher Self* - this is a layer that is the connection to the 'other side', to the metaphysical self, to the MDX multi-dimensional self. This layer is primarily an input channel that provides information to the other Human Design centers, and therefore there is not an existing Human Design center that this plugs into. There can be bi-directional energy flows to and from the The Higher Self, but in this model this is primarily an input channel to the evolved design.

The Triad of Lemuria

Layer 07: *Spiritual Awareness* - this is a layer of divine revelation that focuses on the beginning of spiritual awareness by bringing about the end of spiritual innocence. In Human Design this layer is related to the [Ajna Center] which conveys the attribute of conceptualization. Part of this conceptualization has been the exploration of deity, God, and Spirit.

Layer 08: *The Master Akashic Record* - the Akash can be defined as the energies of Gaia as referenced to humanity, and this Akash creates the Akashic Record, a history of all that has happened to the individuals on Earth. This energy is crystalline in nature. In the evolved Human

Design model, this layer is new, serving primarily as an input of energies from the Earth and of the histories of our essence.

Layer 09: *Essence of Healing* - this layer responds to the multidimensional energy of human consciousness. What you think, you create. What you believe, you are. The Essence of Healing can usually be supported in the body when there is dis-ease or bodily conflict by reviewing what you are thinking and what you believe. In Human Design, this layer is related to the [Willpower / Heart Center] which focuses on the expressions of the ego.

The Triad of the Divine God

Layer 10: *Divine Belief* - in this fully quantum layer resides your divine blueprint of life and the begins the human's search for God. This layer is quiet until activated by the human. This layer can help the human to discover divinity on their own through the essence of grace. In Human Design this layer is related to the [Head Center] with the keyword of inspiration. Belief is a mental construct that provides a matrix for understanding the world in which we live, and the matrix can change if beliefs are changed.

Layer 11: *Divine Male / Feminine Balance* - this quantum layer works to correct the imbalance in the male and female balance that has existed for a millennium or more. The Divine Female is experiencing a resurgence to create this balance, or perhaps it is the time for leadership to shift to the females through the compassionate aspects of this layer. In Human Design this layer is related to the [Solar Plexus Center] which focuses on the keywords of emotional and spiritual awareness. It is perhaps the attunement to emotional intelligence that enables us to balance both male and feminine energies.

Layer 12: *The Essence of the Sacred Creator (God)* - this is the quantum connection to the creative and sacred energy of the Universe and that which is everywhere with no beginning or end. The function of this layer is to create the life force of God within the human and other beings. This layer is interlaced with the other eleven layers. In the evolved Human Design model, this is a new center which takes quantum celestial sacred energy in and distributes it to the other centers.

A Summary of the Layers

The charts below provide a summary of these concepts. The first image is the *Portal of Interface* which takes energies in and translates them into the Human Design centers. This twelve-sided dodecagon, as the Portal of Interface, links the twelve centers to the Human Design centers, and as such, it becomes part of the Human Design body graph or model. This attachment Portal of Interface exists within each cell.

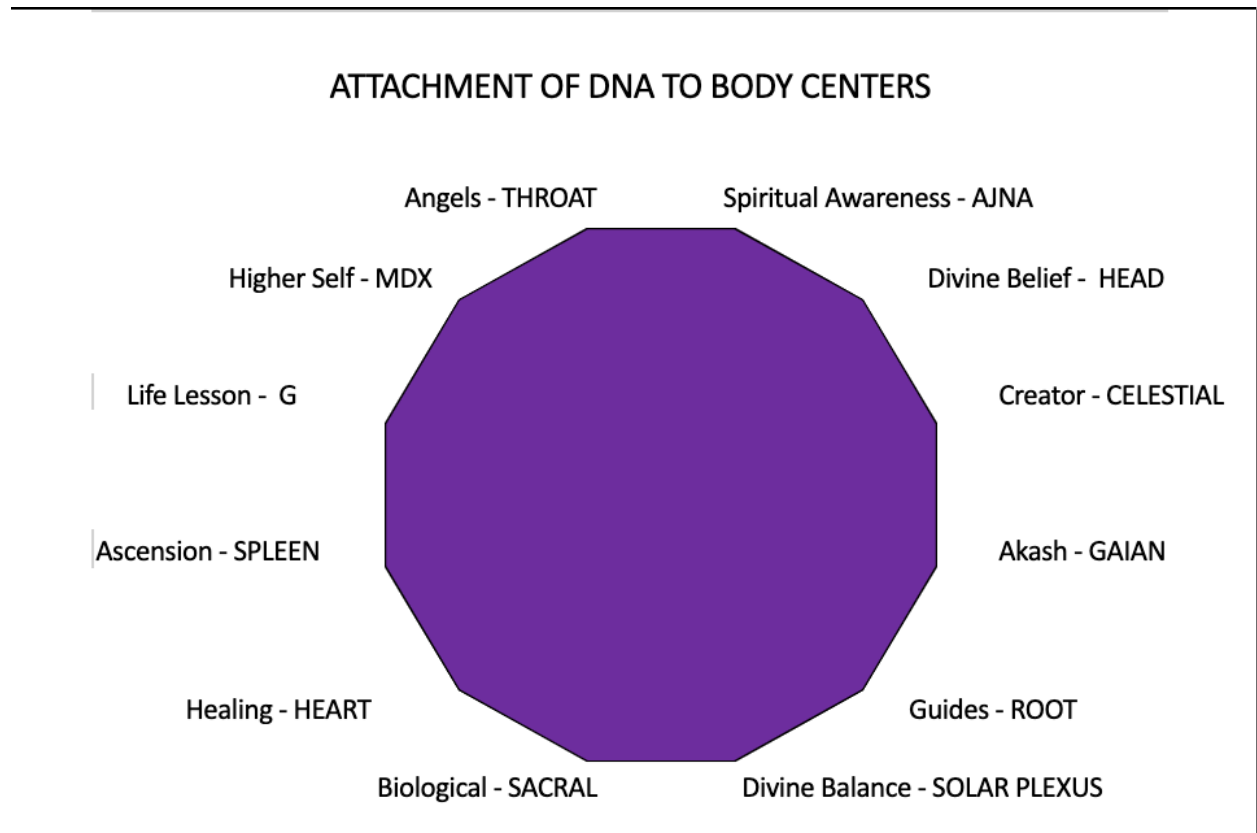

Below you can find two charts. The first is a ranking by the Human Design Centers, the second is ranked by the DNA centers. Please note that the colors on the far right column relate to drawings so that you can follow which triad the centers belong to in future schematics.

Number	12 Centers	HD Key	DNA relationship	DNA gate	Group	Color
12	Celestial Input	*new	Creator	12	4	purple
11	Head	Inspiration	Divine Belief	10	4	purple
10	Anja	Conceptualization	Spiritual Awareness	7	3	green
9	Throat	Metamorphosis	Angels	5	2	blue
8	G	Direction	Life Lesson	2	1	orange
7	Heart	Ego	Healing	9	3	green
6	Spleen	Intuitive Awareness	Ascension Activation	3	1	orange
5	Sacral	Vitality and Reproduction	Biological	1	1	orange
4	Solar Plexus	Emotional Spiritual Awareness	Divine Male Female Balance	11	4	purple
3	Root	Evolution and Drive	Guides	4	2	blue
2	DNA MDX	*new	Higher Self	6	2	blue
1	Gaian Input	*new	Akashic Link	8	3	green

Number	12 Centers	HD Key Center Meaning	DNA relationship	DNA gate	Group	Color
12	Celestial Input	*new	Creator	12	4	purple
4	Solar Plexus	Emotional Spiritual Awareness	Divine Male Female Balance	11	4	purple
11	Head	Inspiration	Divine Belief	10	4	purple
7	Heart	Ego	Healing	9	3	green
1	Gaian Input	*new	Akashic Link	8	3	green
10	Anja	Conceptualization	Spiritual Awareness	7	3	green
2	DNA MDX	*new	Higher Self	6	2	blue
9	Throat	Metamorphosis	Angels	5	2	blue
3	Root	Evolution and Drive	Guides	4	2	blue
6	Spleen	Intuitive Awareness	Ascension Activation	3	1	orange
8	G	Direction	Life Lesson	2	1	orange
5	Sacral	Vitality and Reproduction	Biological	1	1	orange

Sources:

"Living Your Design, A Manual for Cellular Transformation" Lynda Burnnell, 2011

"Kryon Book 12, The Twelve Layers of DNA", Lee Carroll, 2010

One may wonder why the Solar Plexus with its Emotional Spiritual Awareness isn't linked to the Ajna for Spiritual Awareness. This is because to obtain Divine Male Female Balance, the 'emotional' component of spiritual awareness must be present, whereas to understand spiritual awareness one must be able to conceptualize, and this conceptualization is a key function of the Ajna where emotion does not necessarily need to be present. To achieve Divine Balance, the emotions of both the male and the female must be understood and honoured.

NEW MODELS OF EXISTENCE

Earlier in this article I provided schematics of different configurations in the macro life structures on the planet (plants, insects, etc.). Based on the twelve layers of DNA, these configurations have been modified to merge the two Kyron and Human Design models. Denoting the multi-dimensional aspect of the new configuration, these models will be assigned the signifier of MDX.

MDX PLANTS (3 + 3 = 6 Centers): The new model takes the original model and adds the three new centers.

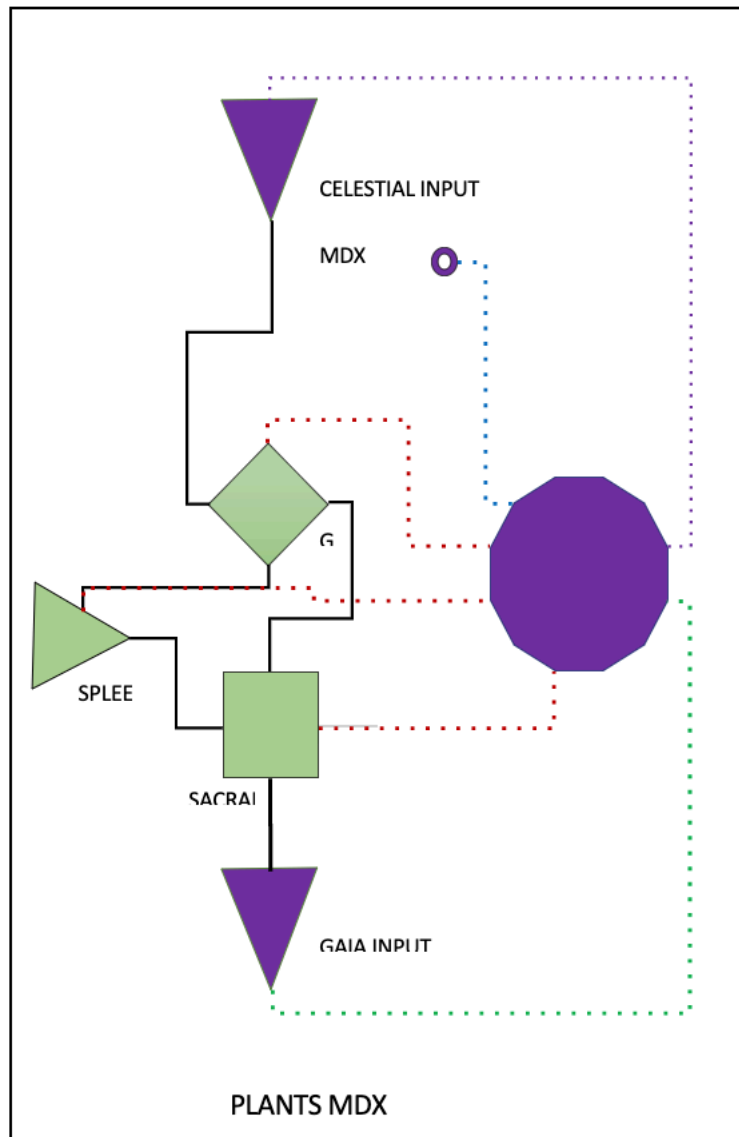

In this new model we have the following Centers to Layer configurations:

- Gaia Input - new
- Sacral - *Vitality and Reproduction to Biologic*
- Spleen - *Intuitive Awareness to Ascension Activation*
- G - *Direction to Life Lesson*
- MDX DNA - new
- Celestial Input - new

Note that all major entities have access to these new MDX centers of [Gaia Input, MDX DNA, and Celestial Input]. There is more of a connection to the consciousness, and DNA moves into a meta-DNA with the metaphysical aspect enabled. It is possible that plants and other configurations have always had this configuration, and perhaps it is just the humans who are 'catching up'. Do we just need to look beyond the entitlement of self-importance and domination as the premier species?

It is also a concept that with the new MDX centers being prevalent across all models, there is more of a conscious and unconscious interaction within all life on the planet. It is possible that this isn't a new concept and that life has always interacted in this manner.

MDX INSECTS (4 + 3 = 7 Centers): MDX Insects takes the plant configuration and adds the [Throat] center.

Throat - *Metamorphosis to Angels*

The addition of the Throat adds to the ability of Insects and other beings with this center to change or metamorphose their environment through communication.

The graph for the MDX Insects appears below.

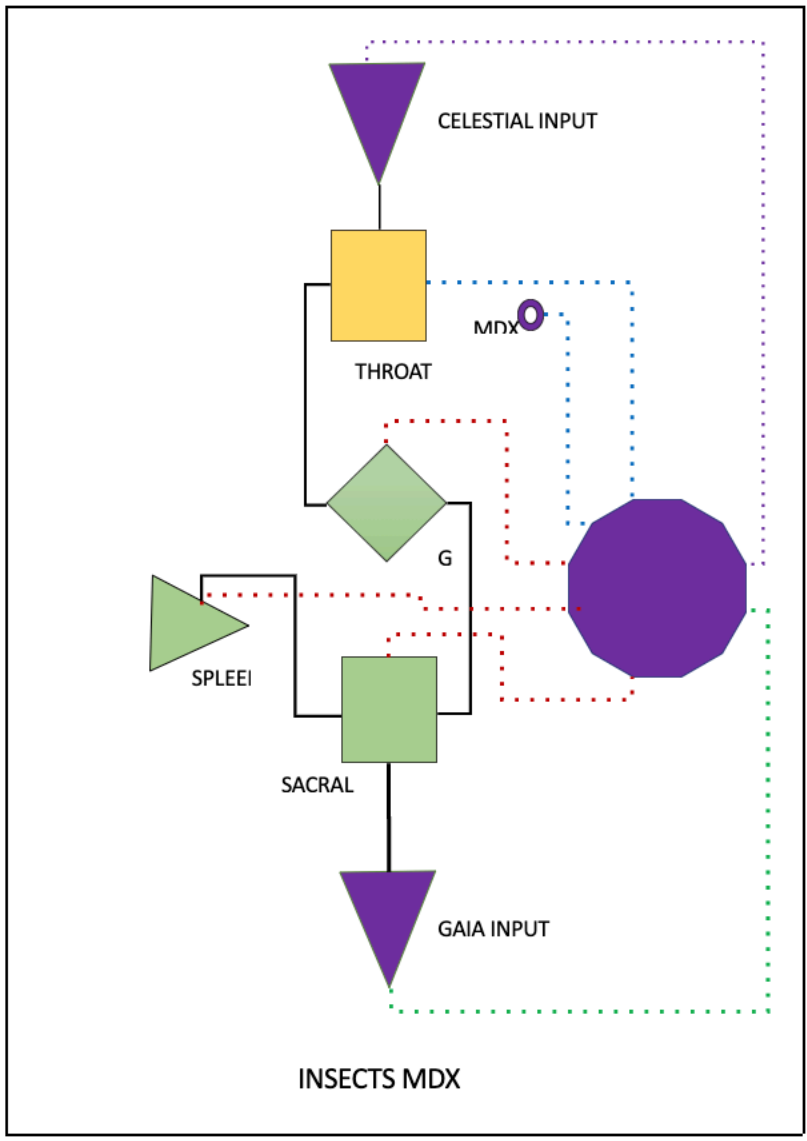

MDX FISH REPTILES BIRDS (4 + 3 = 7 Centers):

The MDX FRB group is similar to the Insects except that it has a different configuration in the way the [Throat] is connected.

The graph for the MDX FRBs is shown below.

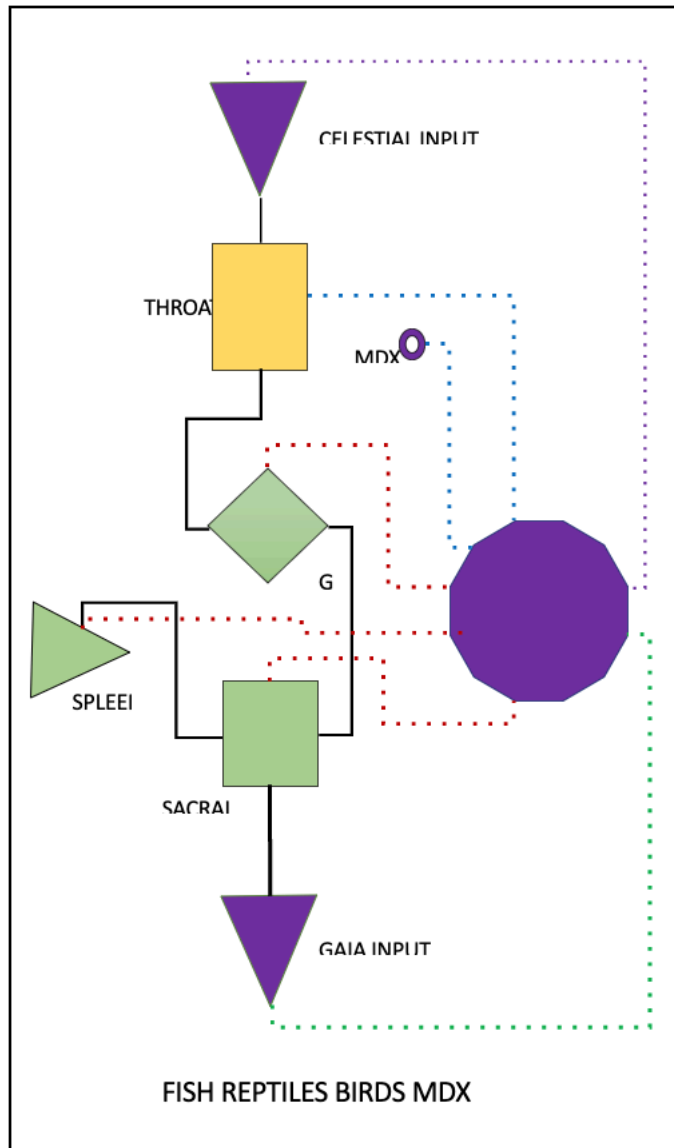

MDX MAMMALS (5 + 3 = 8 Centers): Mammals represent the next evolutionary addition of a body center by way of the [Root Center] addition.

Root - *Evolution and Drive to Guides*

The graph for MDX Mammals is shown below.

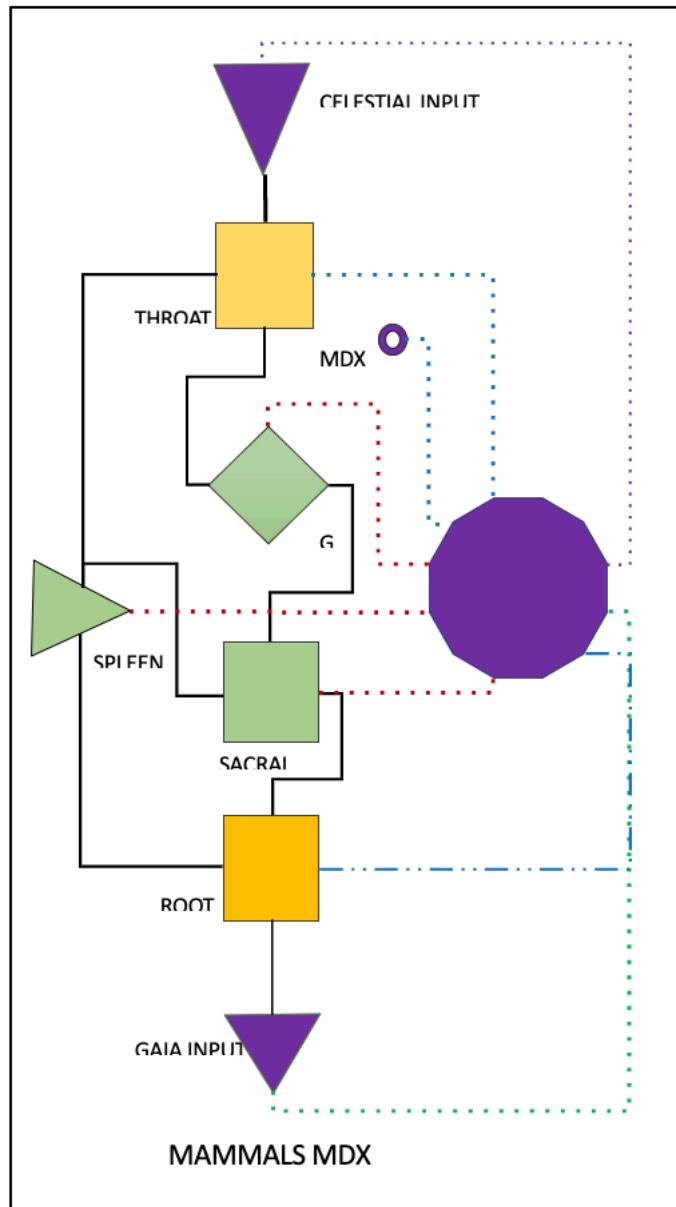

MDX Humans, or the New Humans (9 + 3 = 12 Centers):

The MDX model applies now to humans in our post-2012-evolution. With this evolution and the understanding that we are multi-dimensional, we can begin to work collaboratively towards our highest form.

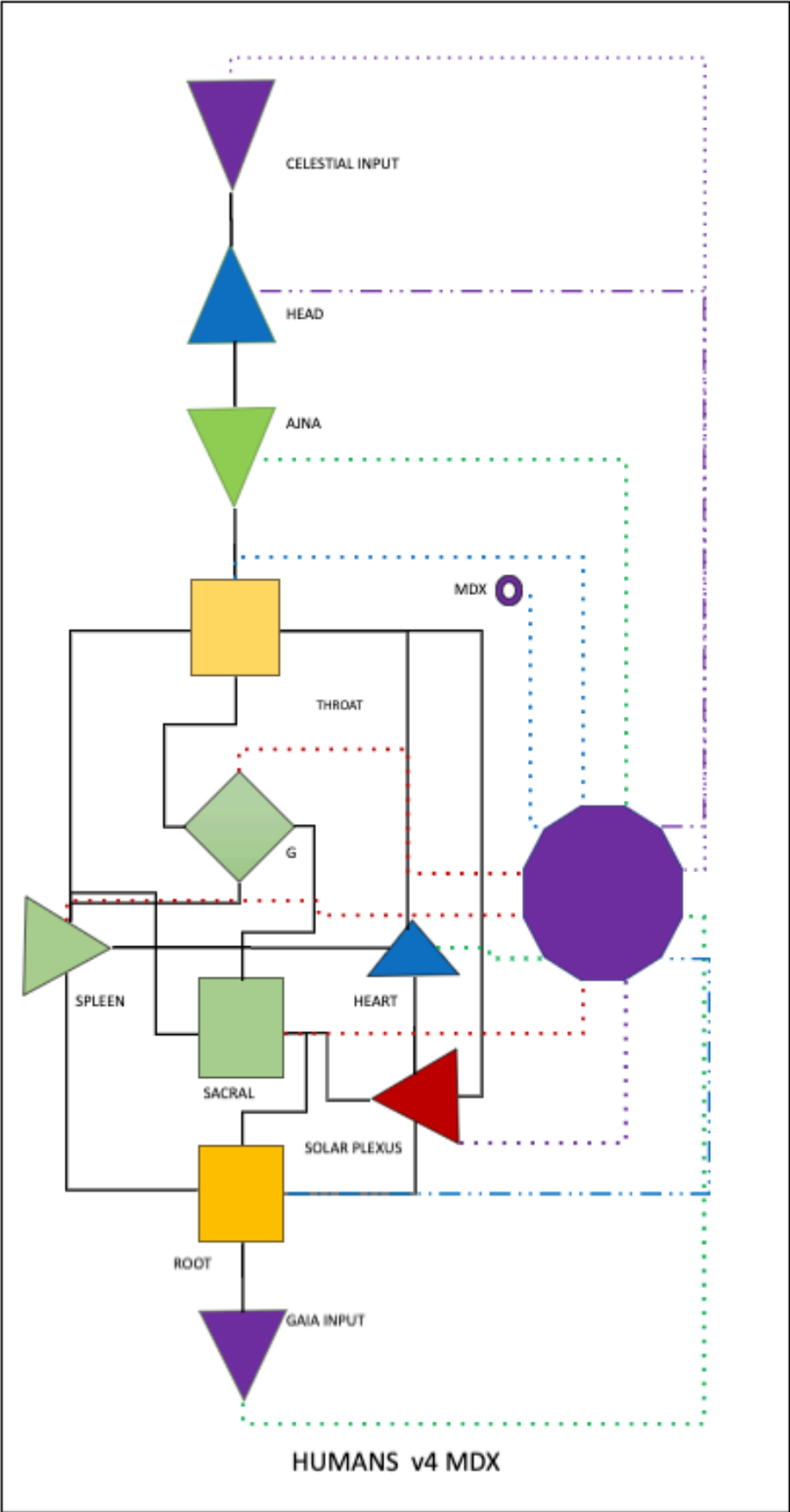

In the words of Ra Uru Hu, the founder of the Human Design system, *“With understanding comes a genuine revolution, the realignment of life and the awakening of awareness. Most important to recognize is that this is knowledge to be experimented with. There is a ‘way’, but it can only be Your Way. Allow these (thoughts) to guide and inform you, and then, if it is correct for you, enter into the most extraordinary journey of your life.”*

In the words of Kryon, *“Now you have some of the first signs you’ve ever had since you were Human, that this planet can move into graduation, vibrate higher and become part of a confluence of energy that you’ve only dreamed about...and you’re sitting on the edge of it.*

In summary, we don’t know where we are going, but perhaps now we are aware that we have higher capabilities to solve our problems. Maybe it will be a long time until we live as one-people, or maybe we never will, but when we look at different systems of knowledge, whether it is Kryon as channeled by Lee Carroll, or through the work of Ra Uru Hu in Human Design, they can each provide a fabric of understanding that moves us down the road. Eventually they will merge and become part of a common understanding. This article is a part of that merger.

In the words of Mary Rodwell, *“It appears that this Awakening is for all of us, if we desire it, and when we become conscious of our programming and conditioning, it enables us to explore this matrix with greater freedom and to perhaps reclaim what is lost.”* [Introduction page 7].

Let us Awaken and Reclaim!

Respectfully Submitted,

Richard BlueStar
Ra Ri Ki Mu
Richard L. Hall
2020Oct15

Bibliography

Carroll, Lee, The Twelve Layers of DNA - An Esoteric Study of the Mastery Within (Kryon Book 12), 2010, Platinum Publishing House, ISBN: 978-1933465-050.

Hu, Ra Uru & Burnell, Lynda, The Definitive Book of Human Design - The Science of Differentiation, 2011, HDC Publishing, ISBN: 978-0615552-149

Rodwell, Mary, The New Human - Awakening to our Cosmic Heritage, 2016, New Mind Publishers, ISBN: 978-0980755-510