

Cupola Data
 Overall Height = 16' -6"
 Base Width = 6'
 Unit Weight = 925 lbs.

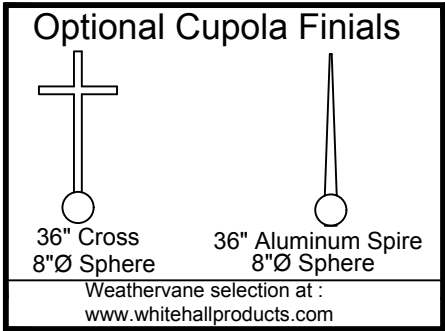

Base Panels - See Available Options Above

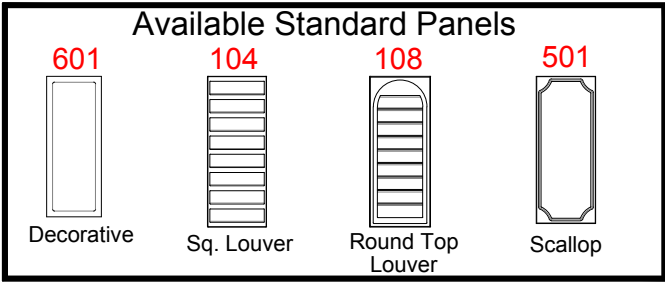
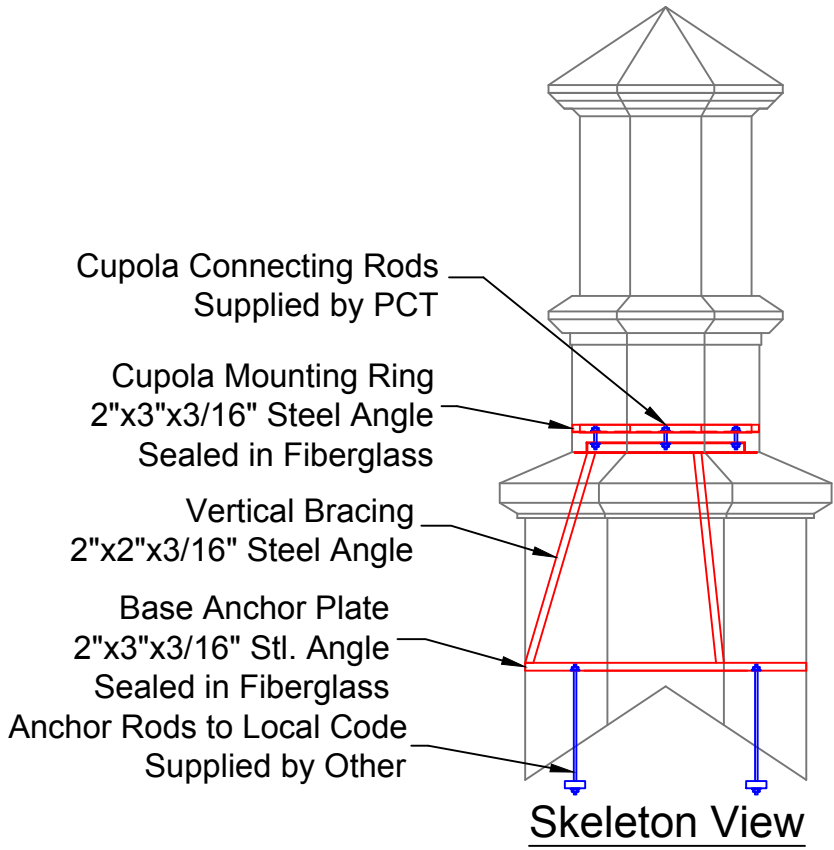
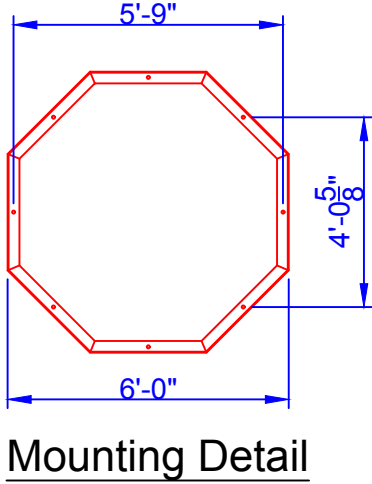
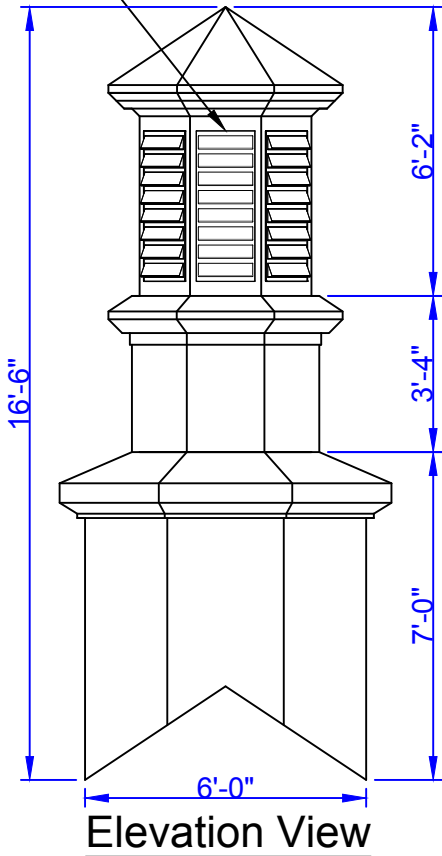

PIEDMONT
 COMPOSITES & TOOLING

33 Lewittes Rd.
 Taylorsville, NC 28681
 Phone: 828-632-8883
 Fax: 828-632-5585
www.piedmontcomposites.com

CUPOLA

Model : **970LPK**

Scale:
 N/A

Drawn by:
 C.BOTHOS

Created On
 -

Updated On
 03/27/19

Note: All drawings are the property of Piedmont Composites & Tooling, LLC. Variation in material thickness, dimension and weight may occur. PCT reserves the right to change or modify design at anytime without notice.