

**No.1**  
**CLAMP**



MADE IN MALAYSIA



# JS CLAMP

HIGH QUALITY TOGGLE CLAMP



Vertical  
Toggle  
Clamp



Horizontal  
Toggle  
Clamp



Latch Toggle  
Clamp



Push & Pull  
Toggle Clamp



Heavy Duty  
Weldable  
Clamp



Air Power  
Toggle  
Clamp

**WE ARE EXPORTER :**  
The exporter of high quality Toggle Clamp,  
Latch, Machine Mount, Revolving Plate,  
Parts Cabinet, Anti-Vibration Mount  
and other industrial products.



To meet the domestic customers' requirement, the excellent products quality is being recognized and has created a demand in the foreign markets. HUP NGAI INDUSTRY SDN BHD (formerly known as Syarikat Juruteraan Hup Ngai was established in 1973), manufacturer of ISO 9001: 2015 certified. It is a professional company to manufacture excellent quality toggle clamp, toggle link clamp, machine mount, anti-vibration mount, parts cabinet and etc which a trade mark of "JS CLAMP".



Management System  
ISO 9001:2015  
www.tuv.com  
ID 9105038625



# INDEX

• PAGE •



# JSCLAMP

HIGH QUALITY TOGGLE CLAMP

## TOGGLE CLAMP

\*Also available in Stainless Steel



### HORIZONTAL • HANDLE •

Model	Page
H215	1-1
H225*	1-1
H230, H230L	1-1
H230F, H230FL	1-2
H235*, H235B*	1-2
H238*	1-2
H245*, H245B*	1-3
H301*	1-3
H313	1-3
H300, H300L	1-4
H300H, H300HL	1-4
H330, H330L	1-4
H380, H380B	1-5
H381, H381B	1-5
H381H	1-5
H430, H430B	1-6
H440, H440B	1-6
H450, H450B	1-6
H460, H460B	1-7
H500L	1-8
H530L	1-8
H228F	1-9
H384, H384B	1-9
H209, H209B	1-9
H208, H208B	1-10
H520L	1-10
H550L	1-10



### VERTICAL • HANDLE •

Model	Page
V145SB4	2-10
V145SBN	2-10
V209, V209B	2-11
V210S, V210SB	2-11



### LATCH • TYPE •

Model	Page
L130*	4-1
L1305*	4-1
L131*	4-1
L1315*	4-2
L132*	4-2
L133	4-2
L134	4-3
L352*	4-3
L354*	4-3
L138*	4-4
L148*	4-4
L158*	4-5
L350*	4-6
L356*	4-6
L135	4-7
L360*	4-7
L365*	4-7
L137	4-8
L370*, L375*	4-9

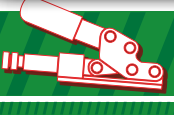

### PUSH & PULL • TYPE •

Model	Page
P102	3-1
P115	3-1
P125	3-1
P130*	3-2
P150	3-2
P152	3-2
P107	3-3
P154	3-3
P156	3-3
P202	3-4
P204*	3-4
P206	3-4
P208	3-5
P340	3-5
P105	3-5
P100	3-6
P109	3-6
P200	3-6
P209	3-7
P300	3-7
P309	3-7
P102S	3-8
P122	3-9
P320	3-9
P330	3-9
P560	3-10
P570	3-10
P580	3-10
P610	3-11
P620	3-11
P625	3-11
P106	3-12
P118	3-12
P170	3-12
P110LH, P110RH	3-13
P120	3-13
P600	3-13
P710	3-14
P720	3-14
P630	3-14
P116	3-15



### VERTICAL • HANDLE •

Model	Page
V101	2-1
V105	2-1
V108*	2-1
V108F*	2-2
V110-L, V110-L1	2-2
V120R*, V120RB*	2-2
V125	2-3
V125R	2-3
V130, V130L	2-3
V141*, V141B*	2-4
V150	2-4
V160	2-4
V170	2-5
V210, V210B	2-5
V310	2-5
V247U, V247UB	2-6
V247S, V247SB	2-6
V130B, V130BL	2-7
V130S, V130LS	2-7
V130SB, V130LSB	2-7
V120, V120B	2-8
V142, V142B	2-8
V208, V208B	2-8
V145S	2-9
V145SB	2-9



### HEAVY DUTY WELDABLE

Model	Page
AR801	5-1
AR802	5-1
AR803	5-1
AR801SB	5-1
AR802SB	5-1

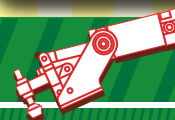

### AIR POWER • TOGGLE CLAMP •

Model	Page
V120RA	6-1
V130A	6-1
V370SA	6-2
H360SA	6-2
V210A	6-3
V247UA	6-3
P330A	6-4
H228FA	6-5



### POWER SCREEN TENSIONER / ACCESSORIES

Model	Page
PST4050	7-1
Rubber Cushion Spindle	7-1
Flanged Washer	7-1
Swivel Foot Spindle	7-2

Note : Engineering changes, dimensions and specifications referred in this catalogue are subject to change without prior notice

\*Also available in Stainless Steel

## JS PRODUCTS



### SQUEEZE ACTION • TOGGLE CLAMP •

Model	Page
SC2050	8-1
SC3075	8-1



### LIFTING • CLAMP •

Model	Page
Horizontal Lifting Clamp	9-1
Vertical Lifting Clamp	9-1



### MOULD • CLAMP •

Model	Page
Refer to page MCH, MCS	9-2



### TOGGLE LINK • CLAMP •

Model	Page
TL01*	10-1
TL02*, TL02K*	10-1
TL03*, TL03K*	10-1
TL04*, TL04K*	10-2
TL05*	10-2
TL06K	10-2
TL116*	10-3
TL124*, TL124K*	10-3
TL118*	10-3
TL119	10-4
TL121	10-4
TL135*	10-4
TL104*, TL104K*	10-5
TL122*	10-5
TL107	10-5
TL127K	10-6
TL129*	10-6
TL305	10-6
TL105*, TL105K*	10-7
TL112*	10-7
TL123*	10-7
TL307*	10-8
TL204*	10-8
TL304*, TL304K*	10-8
TL126*	10-9



### UNIVERSAL RACK CLAMP

Model	Page
URC 6020, URC 6030	11-1



### C - CLAMP

Model	Page
C100, C150, C200	11-2



### HEAVY DUTY • CABINET •

Model	Page
Refer to page A3, F4, F6, G4, G6	12-1



### REVOLVING PLATE

Model	Page
RP160MDSH	13-1
RP16023	13-1
RP160MD	13-1
RP25023F / Kung Fu Twister	13-2



### RACK FOOTING

Model	Page
Refer to page RF	14-1



### MACHINE MOUNT / LEVEL ADJUSTER

Model	Page
Refer to page MM, LA, LAR	15-1



### HEAVY DUTY SQUARE MACHINE MOUNT

Model	Page
Refer to page SMM	15-2



### INDUSTRY ANTI-SLIP RUBBER MATS

Model	Page
ASRM-500500H	15-3
ASRM-500500B	15-3



### HEAVY INDUSTRY ANTI- VIBRATION FLOOR MATS

Model	Page
AVFM-500500T15	15-4
AVFM-500500T20	15-4
AVFM-500500T25	15-4



### LEVELING MOUNT

Model	Page
Refer to page LM, LML	16-1



### LEVELING FEET

Model	Page
LF	16-2



### LEVELING ELEMENT (RUBBER BASE)

Model	Page
Refer to page LERBR	17-1



### LEVELING ELEMENT & RUBBER PAD

Model	Page
Refer to page LE, RBP	17-2

Note : Engineering changes, dimensions and specifications referred in this catalogue are subject to change without prior notice

# INDEX

• PAGE •



# JS CLAMP

HIGH QUALITY TOGGLE CLAMP

## JS PRODUCTS

\*Also available in Stainless Steel



### BB DIE SET

#### Model

Refer to page

#### Page

18-1



### UNIPUNCH

#### Model

A-1-150~A-5-150

#### Page

22-2



### ANTI-VIBRATION MOUNT

#### Model

Refer to page

HHS,HHC,TTS,TTT,HBS,TBS,THC

#### Page

19-1

19-1



### PNEUMATIC INDEX ROTARY TABLE

#### Model

Pneumatic Index Rotary Table

#### Page

23-1



### LONG BASE ANTI-VIBRATION MOUNT

#### Model

Refer to page LBAVM

#### Page

19-2



### TROLLEY

#### Model

CT - BT4015  
CT - BT4030

#### Page

24-1

24-1

UT3 - 1

24-2



### STANDARD ROUND PUNCH

#### Model

SKD  
SKH

#### Page

20-1

20-1



### HAND KNOB

#### Model

HKM, HKF

#### Page

25-1



### STAMPING SAFETY TOOL / DEAD BLOW HAMMER

#### Model

SST-15RT  
SST-30RT  
SST-1~SST-4  
JSH-3

#### Page

21-1

21-1

21-1

21-1



### PLASTIC PULL HANDLE

#### Model

PPH-90  
PPH-120  
PPH-150  
PPH-180

#### Page

26-1

26-1

26-1

26-1

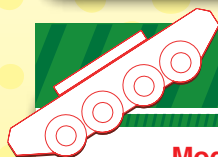

### MACHINE MOVER

#### Model

MV25T  
MV3263  
MVR3263

#### Page

22-1

22-1

22-1



### KUNGFU STAINLESS STEEL RING

#### Model

Kung Fu Stainless Steel Ring

#### Page

22-2

Note : Engineering changes, dimensions and specifications referred in this catalogue are subject to change without prior notice



**HORIZONTAL  
HANDLE  
TOGGLE CLAMP**

**Model : H215**



**Holding Capacity : 27kg MAX**  
**Weight : 30g**

**Handle Moves ... 80°**  
**Arm Moves ... 90°**

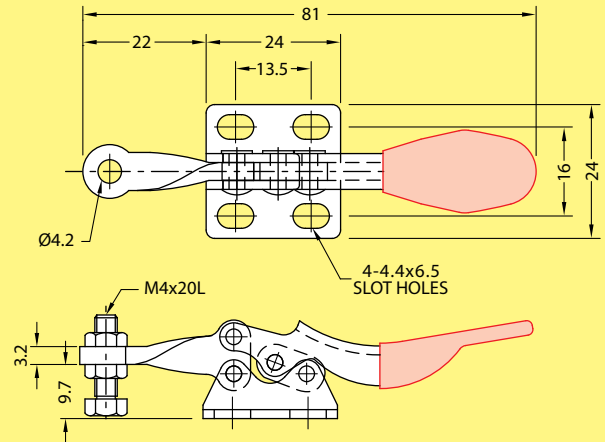

unit : mm

**Model : H225**

\*Also available in Stainless Steel

**Model : H225SS**

(Stainless steel model is supplied with stainless steel hex. bolt M4 x 20L )



**Holding Capacity : 27kg MAX**  
**Weight : 33g**

**Handle Moves ... 80°**  
**Arm Moves ... 90°**

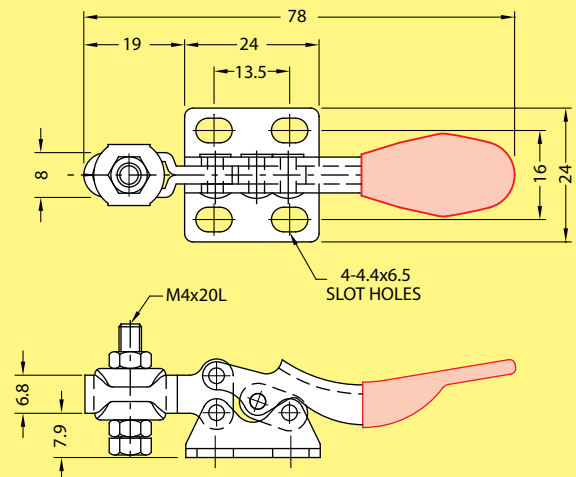

unit : mm

**Model : H230, H230L**

**H230**

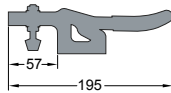

**H230L**

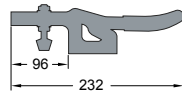

**Holding Capacity : 227kg MAX**  
**Weight : 364g, 385g**

**Handle Moves ... 58°**  
**Arm Moves ... 80°**

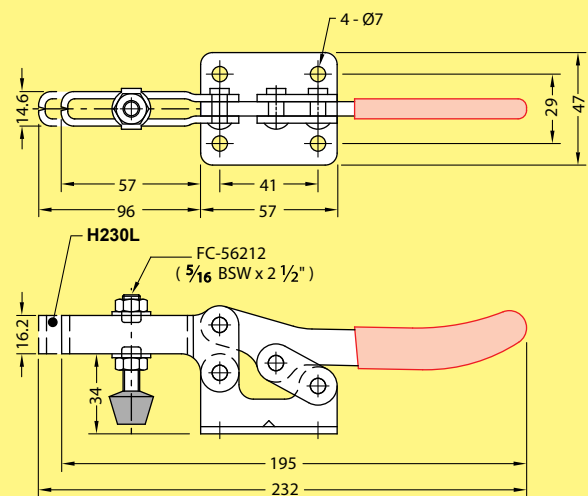

unit : mm

# HORIZONTAL HANDLE

• TOGGLE CLAMP •



## Model : H230F, H230FL

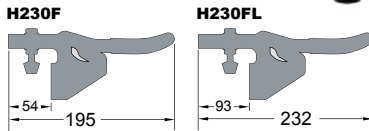
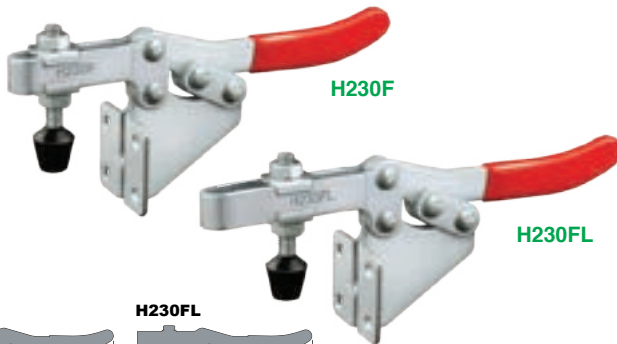

**Holding Capacity :** 227kg MAX  
**Weight :** 428g, 425g

**Handle Moves ...** 58°  
**Arm Moves ...** 85°

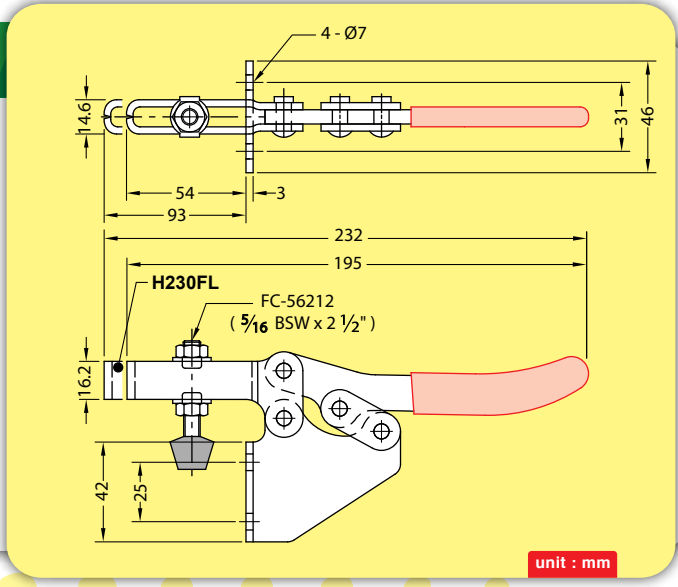

unit : mm

## Model : H235, H235B

\*Also available in Stainless Steel

### Model : H235SS, H235BSS

(Stainless steel models are supplied with stainless steel hex. bolt 1/4 BSW x 1 3/4")

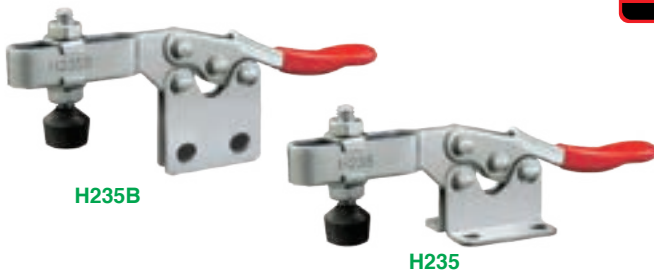

H235B

H235

**Holding Capacity :** 90kg MAX  
**Weight :** 130g, 130g

**Handle Moves ...** 60°  
**Arm Moves ...** 85°

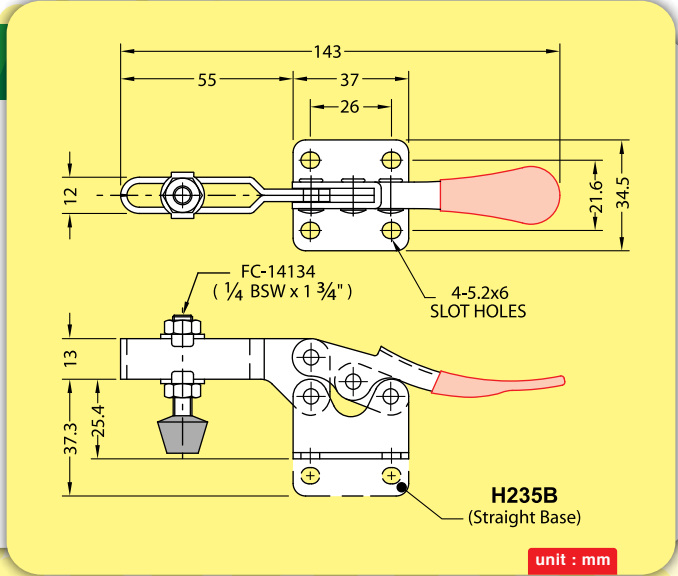

unit : mm

## Model : H238

\*Also available in Stainless Steel

### Model : H238SS

(Stainless steel models are supplied with stainless steel hex. bolt 1/4 BSW x 1 3/4")



**Holding Capacity :** 100kg MAX  
**Weight :** 148g

**Handle Moves ...** 87°  
**Arm Moves ...** 79°

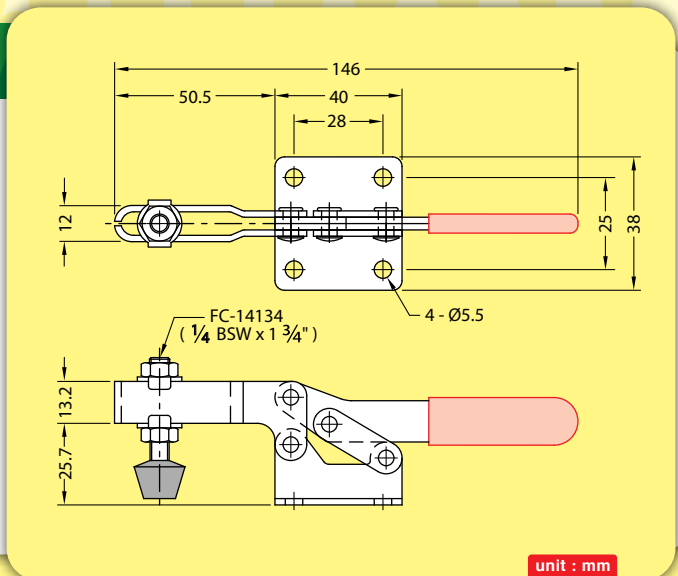

unit : mm



**HORIZONTAL  
HANDLE  
• TOGGLE CLAMP •**

**Model : H245, H245B**

\*Also available in Stainless Steel

**Model : H245SS, H245BSS**

(Stainless steel models are supplied with stainless steel hex. bolt  $\frac{5}{16}$  BSW x 2")

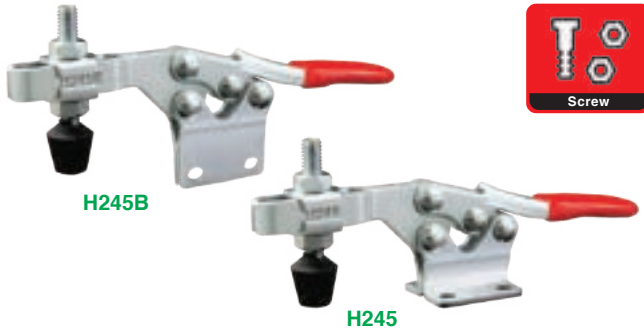

**Holding Capacity : 227kg MAX**  
**Weight : 278g, 278g**

**Handle Moves ... 65°**  
**Arm Moves ... 90°**

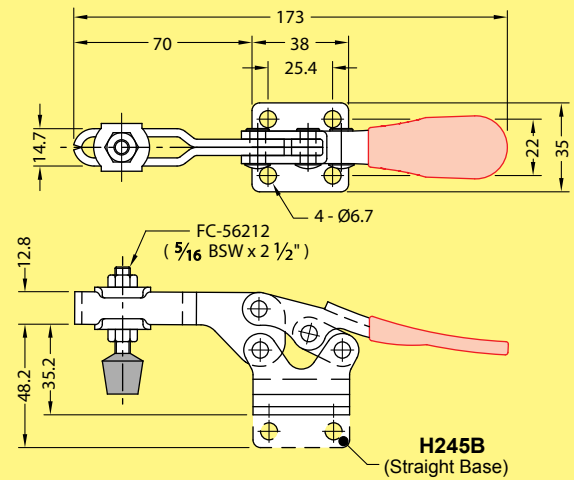

unit : mm

**Model : H301**

\*Also available in Stainless Steel

**Model : H301SS**

(Stainless steel model is supplied with stainless steel hex. bolt M4 x 40L)

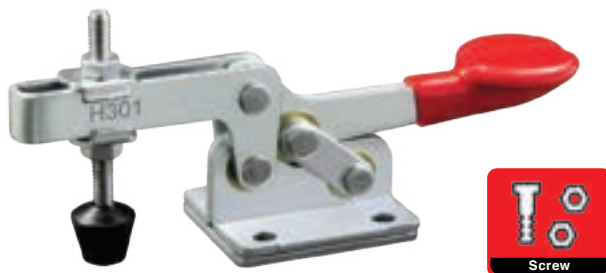

**Holding Capacity : 30kg MAX**  
**Weight : 106g**

**Handle Moves ... 55°**  
**Arm Moves ... 65°**

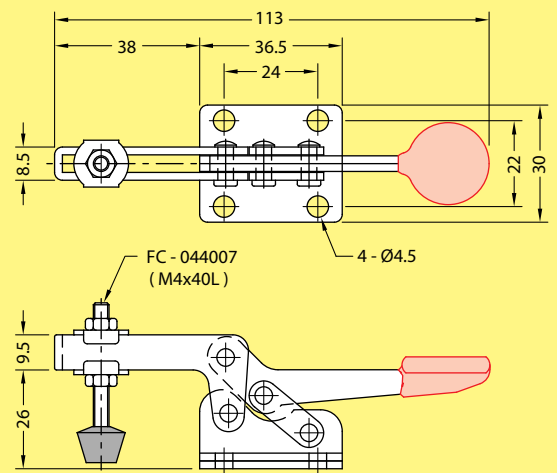

unit : mm

**Model : H313**



**Holding Capacity : 68kg MAX**  
**Weight : 112g**

**Handle Moves ... 90°**  
**Arm Moves ... 90°**

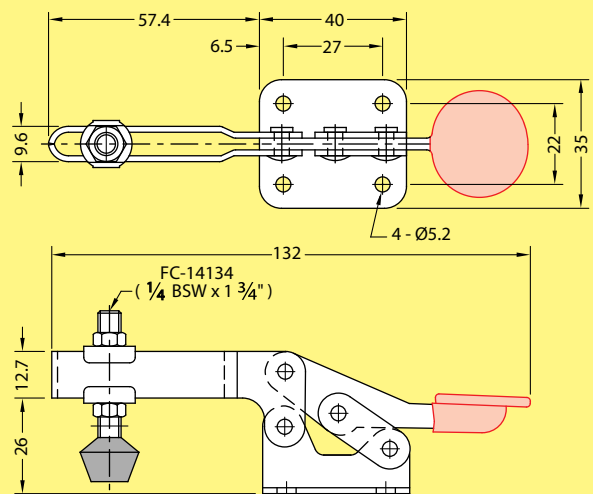

unit : mm



## HORIZONTAL HANDLE

• TOGGLE CLAMP •



### Model : H300, H300L

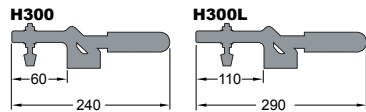

**Holding Capacity :** 400kg MAX  
**Weight :** 629g, 672g

**Handle Moves ...** 83°  
**Arm Moves ...** 81°

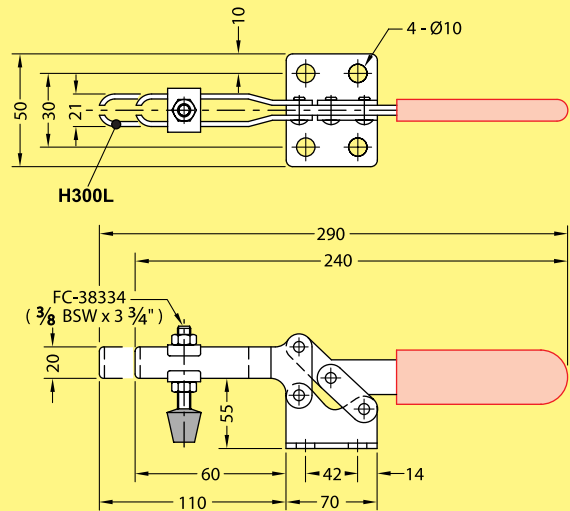

unit : mm

### Model : H300H, H300HL

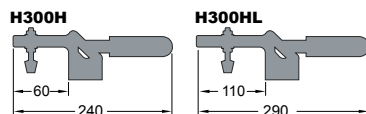

**Holding Capacity :** 400kg MAX  
**Weight :** 716g, 766g

**Handle Moves ...** 83°  
**Arm Moves ...** 81°

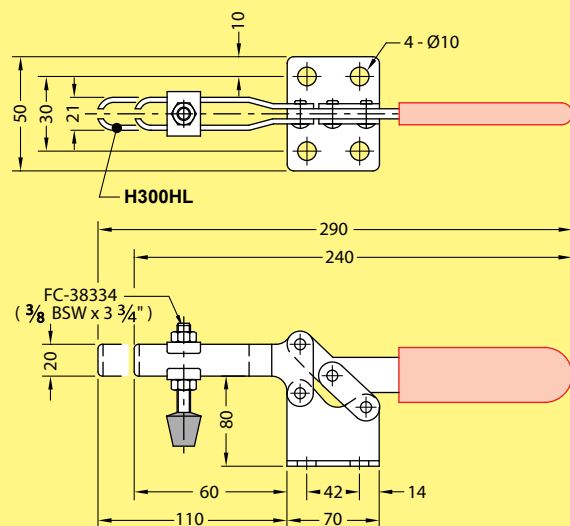

unit : mm

### Model : H330, H330L

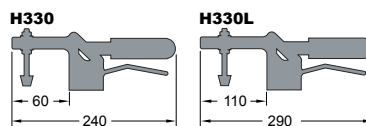

**Holding Capacity :** 400kg MAX  
**Weight :** 808g, 856g

**Handle Moves ...** 83°  
**Arm Moves ...** 81°

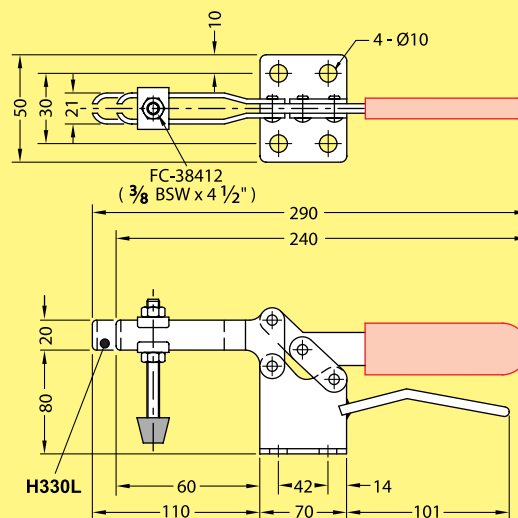

unit : mm



**HORIZONTAL  
HANDLE  
• TOGGLE CLAMP •**

**Model : H380, H380B**

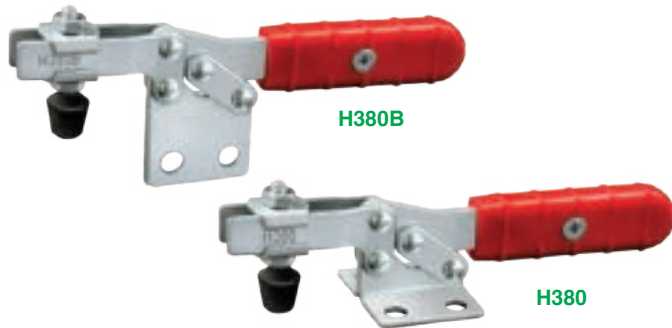

**Holding Capacity : 250kg MAX**  
**Weight : 228g, 230g**

**Handle Moves ... 84°**  
**Arm Moves ... 82°**

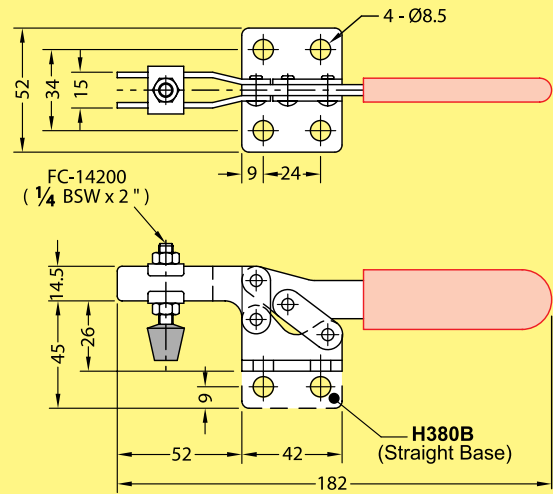

unit : mm

**Model : H381, H381B**

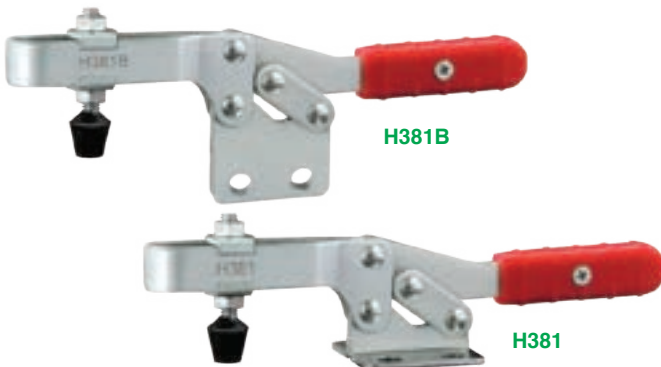

**Holding Capacity : 280kg MAX**  
**Weight : 498g, 505g**

**Handle Moves ... 87°**  
**Arm Moves ... 82°**

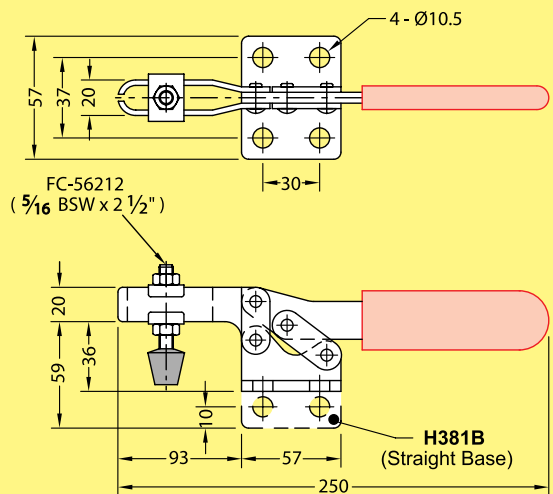

unit : mm

**Model : H381H**



**Holding Capacity : 280kg MAX**  
**Weight : 638g**

**Handle Moves ... 87°**  
**Arm Moves ... 82°**

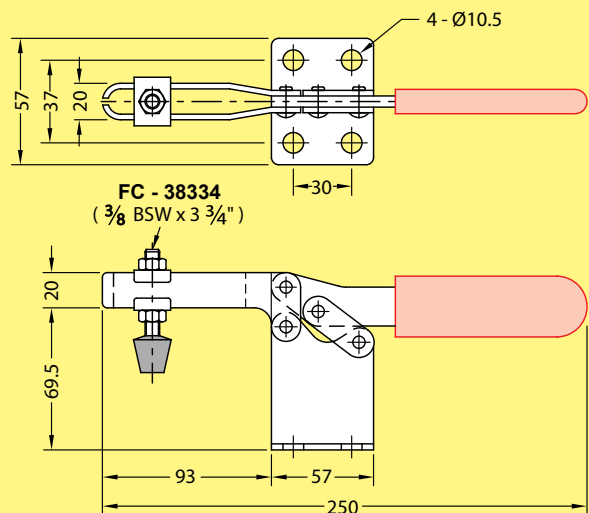

unit : mm

# HORIZONTAL HANDLE

• TOGGLE CLAMP •



## Model : H430, H430B



H430



H430B

Holding Capacity : 68kg MAX  
Weight : 83g

Handle Moves ... 55°  
Arm Moves ... 95°

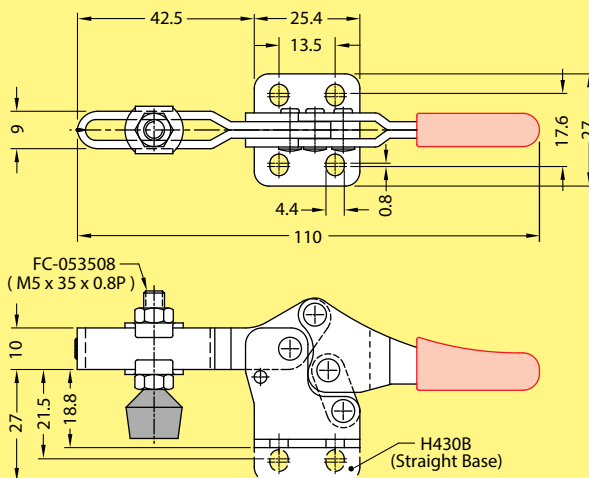

unit : mm

## Model : H440, H440B



H440



H440B

Holding Capacity : 90kg MAX  
Weight : 207g

Handle Moves ... 55°  
Arm Moves ... 95°

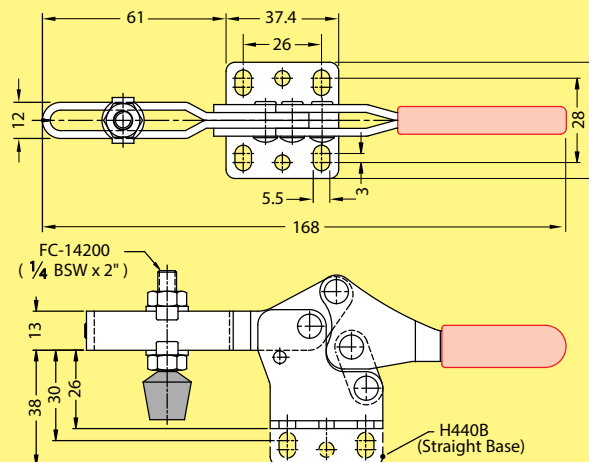

unit : mm

## Model : H450, H450B



H450



H450B

Holding Capacity : 227kg MAX  
Weight : 341g

Handle Moves ... 55°  
Arm Moves ... 95°

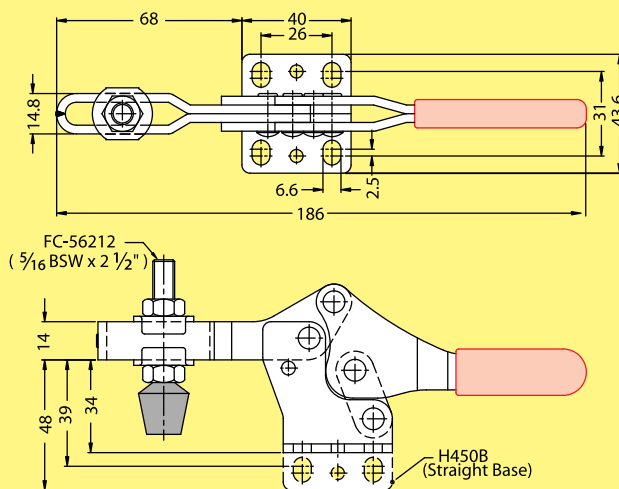

unit : mm



**HORIZONTAL  
HANDLE  
• TOGGLE CLAMP •**

**Model : H460, H460B**

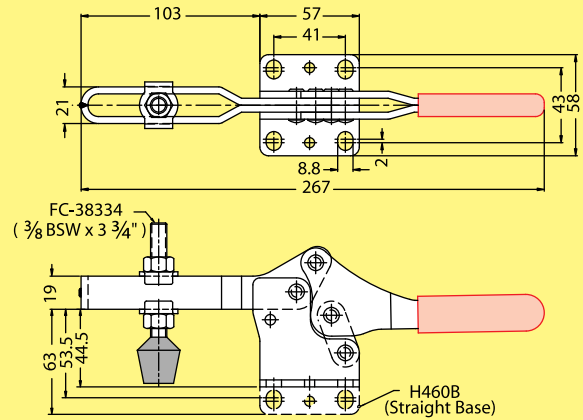

unit : mm

**Holding Capacity : 340kg MAX**  
**Weight : 737g**

**Handle Moves ... 55°**  
**Arm Moves ... 95°**

**Type of Toggle Clamp**



**Horizontal Handle**



**Vertical Handle**



**Push / Pull**

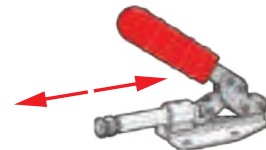

**Latch**



**HORIZONTAL HANDLE**  
• TOGGLE CLAMP •



**Model : H500L**

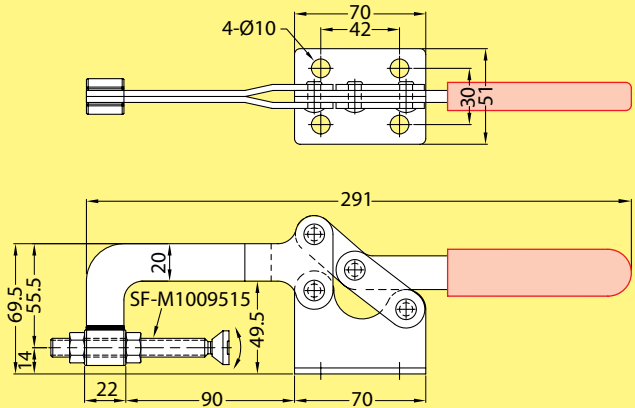
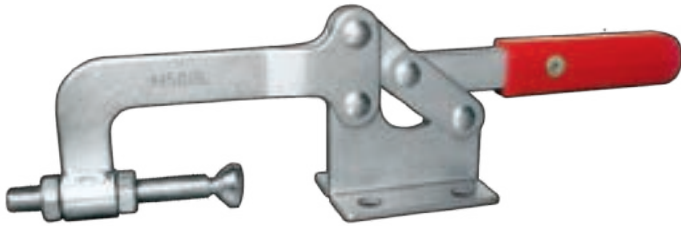

**Holding Capacity : 300kg MAX**  
**Weight : 706g**

**Handle Moves ... 83°**  
**Arm Moves ... 81°**

unit : mm

**Model : H530L**

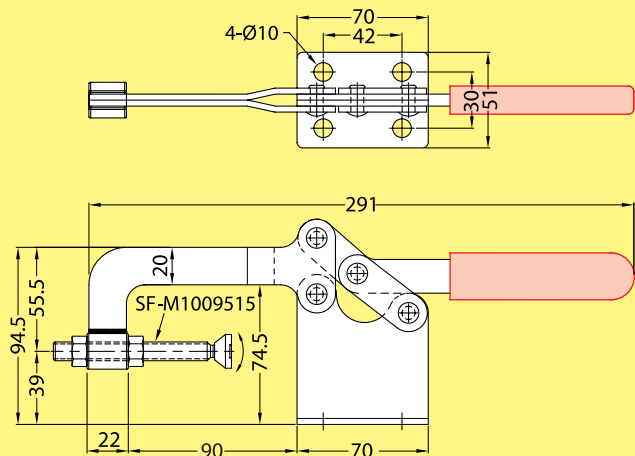
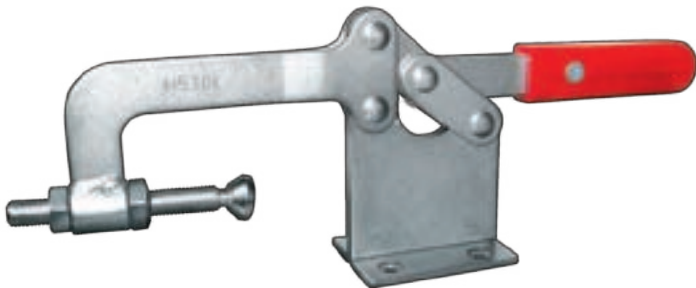

**Holding Capacity : 300kg MAX**  
**Weight : 790g**

**Handle Moves ... 83°**  
**Arm Moves ... 81°**

unit : mm



**HORIZONTAL  
HANDLE  
TOGGLE CLAMP**

**Model : H228F**

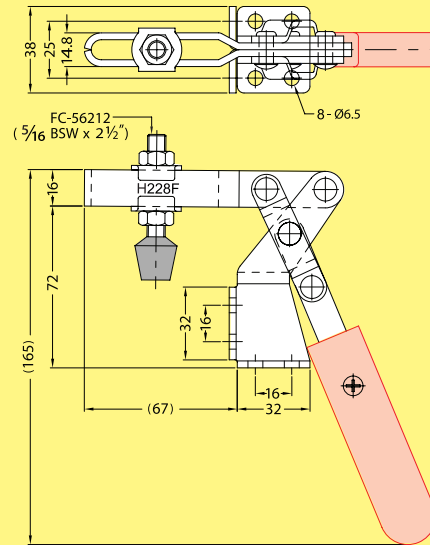

**Holding Capacity : 100kg MAX**  
**Weight : 431g**

**Handle Moves ... 185°**  
**Arm Moves ... 65°**

unit : mm

**Model : H384, H384B**

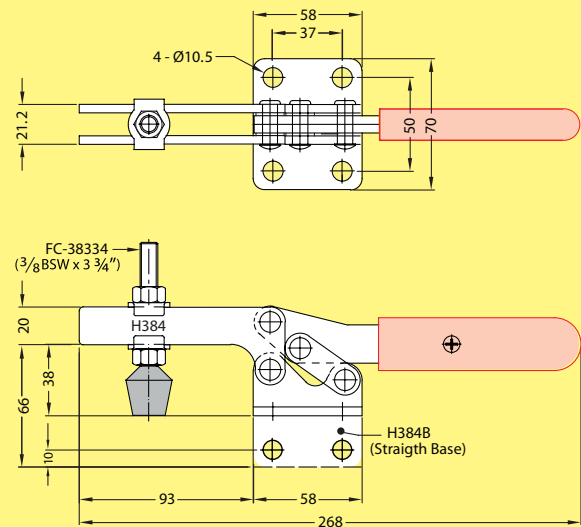

**Holding Capacity : 500kg MAX**  
**Weight : 750g**

**Handle Moves ... 85°**  
**Arm Moves ... 65°**

unit : mm

**Model : H209, H209B**

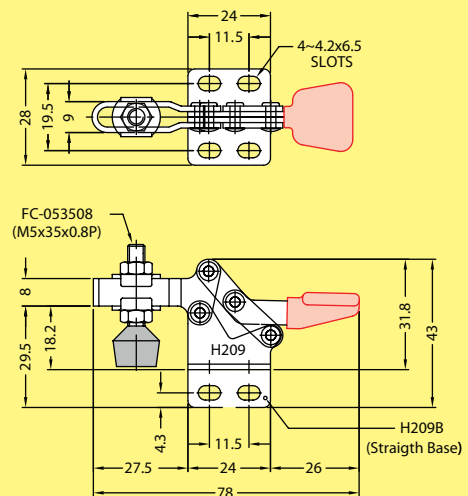

**Holding Capacity : 50kg MAX**  
**Weight : 52g**

**Handle Moves ... 100°**  
**Arm Moves ... 80°**

unit : mm

**HORIZONTAL HANDLE**  
• TOGGLE CLAMP •



**Model : H208, H208B**

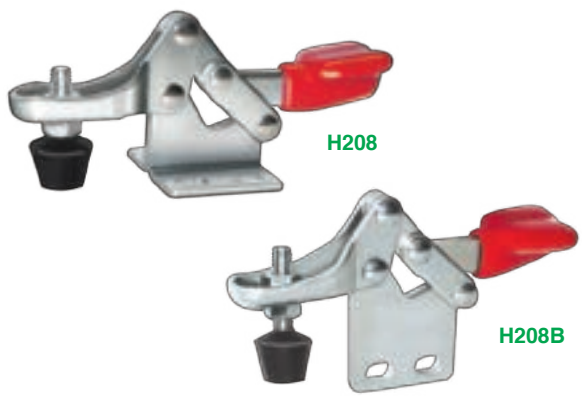

**Holding Capacity : 30kg MAX**  
**Weight : 44g, 44g**

**Handle Moves ... 110°**  
**Arm Moves ... 90°**

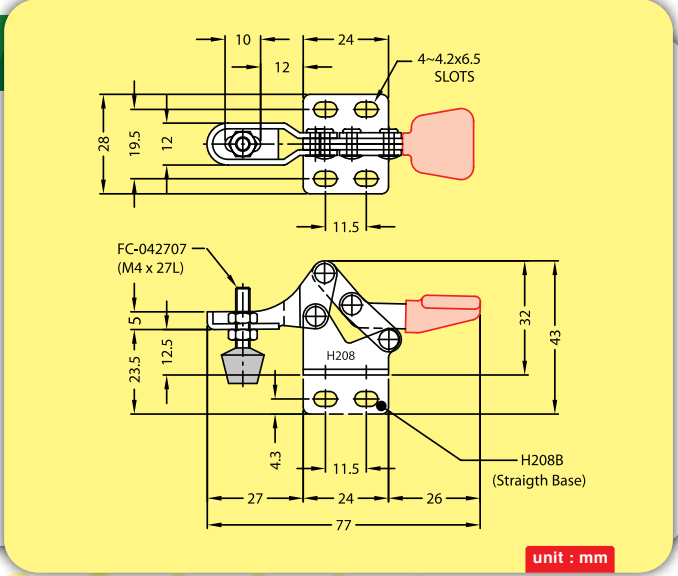

unit : mm

**Model : H520L**



**Holding Capacity : 300kg MAX**  
**Weight : 796 g**

**Handle Moves ... 83°**  
**Arm Moves ... 81°**

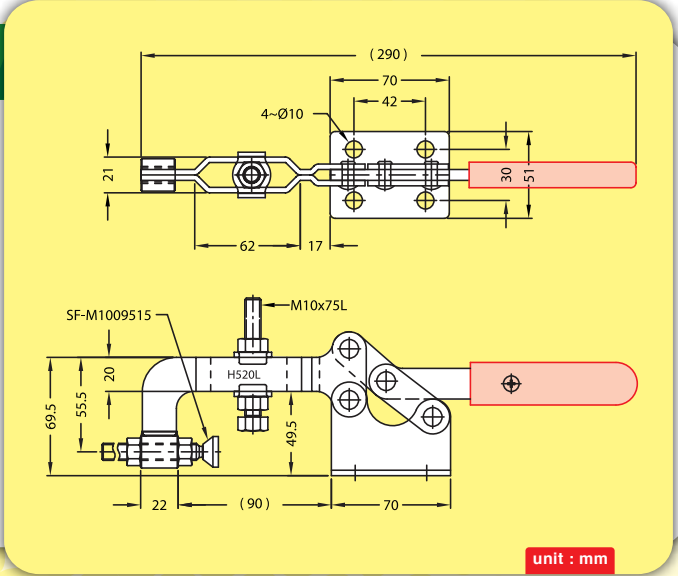

unit : mm

**Model : H550L**



**Holding Capacity : 300kg MAX**  
**Weight : 873g**

**Handle Moves ... 83°**  
**Arm Moves ... 81°**

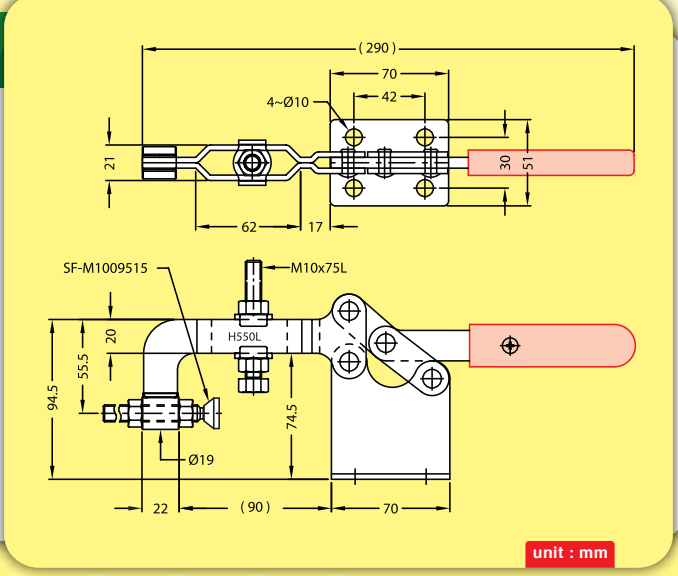

unit : mm



**VERTICAL  
HANDLE  
• TOGGLE CLAMP •**

**Model : V101**



**Holding Capacity : 180kg MAX**  
**Weight : 330g**

**Handle Moves ... 60°**  
**Arm Moves ... 100°**

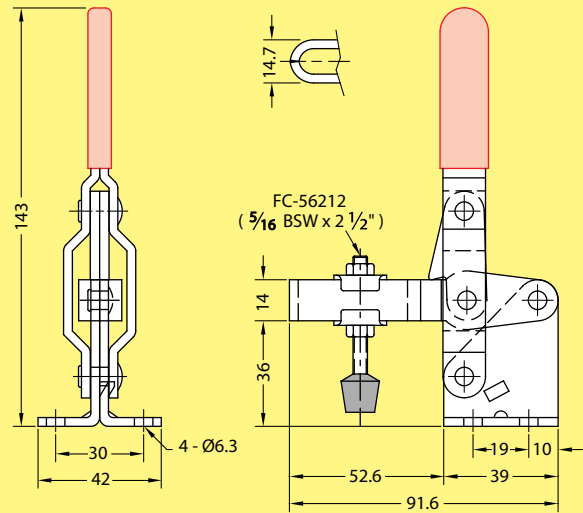

unit : mm

**Model : V105**



**Holding Capacity : 50kg MAX**  
**Weight : 70g**

**Handle Moves ... 56°**  
**Arm Moves ... 100°**

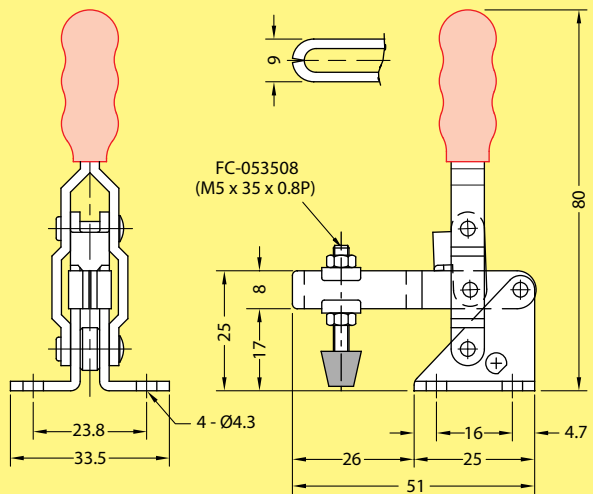

unit : mm

**Model : V108**

\*Also available in Stainless Steel  
**Model : V108SS**  
(Stainless steel models are supplied with stainless steel hex. bolt 1/4 BSW x 1 3/4")



**Holding Capacity : 100kg MAX**  
**Weight : 120g**

**Handle Moves ... 65°**  
**Arm Moves ... 90°**

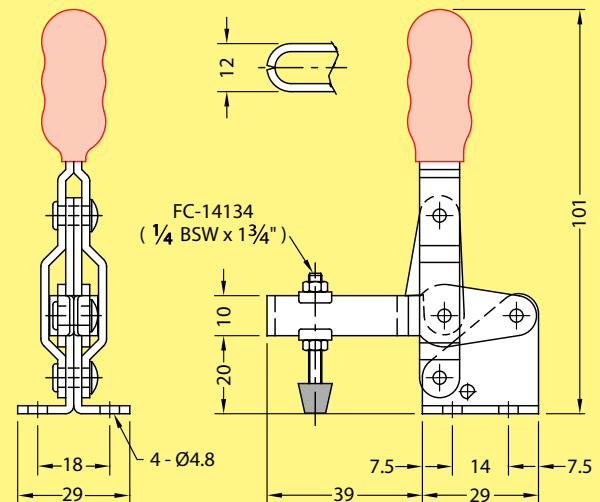

unit : mm



# VERTICAL HANDLE

• TOGGLE CLAMP •



# JSCLAMP

HIGH QUALITY TOGGLE CLAMP

## Model : V108F

\*Also available in Stainless Steel  
**Model : V108FSS**  
 (Stainless steel models are supplied with stainless steel hex. bolt 1/4 BSW x 1 3/4")

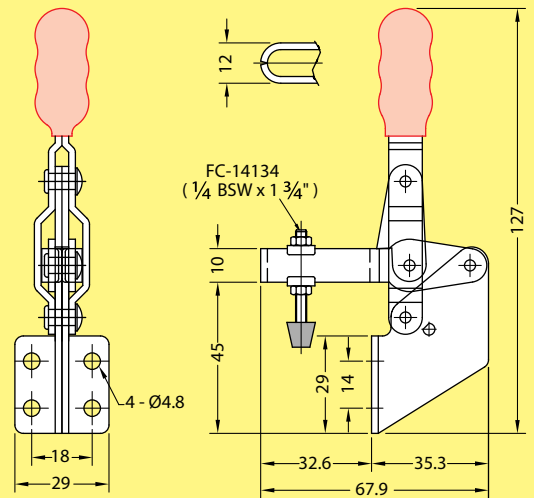

**Holding Capacity : 100kg MAX**  
**Weight : 139g**

**Handle Moves ... 65°**  
**Arm Moves ... 90°**

unit : mm

## Model : V110-L, V110-L1

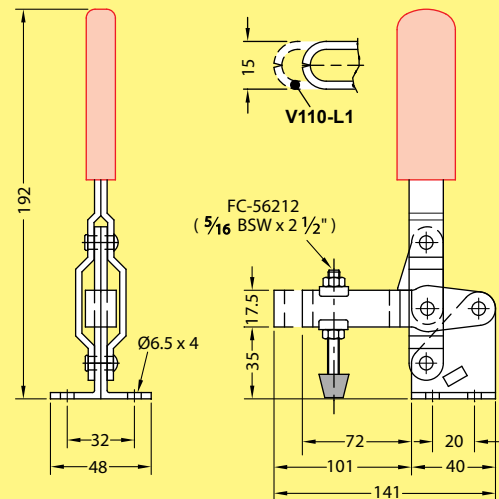
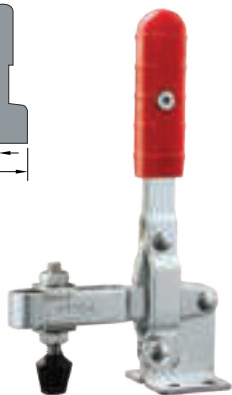
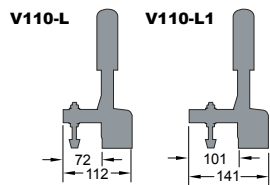

**Holding Capacity : 200kg MAX**  
**Weight : 450g, 475g**

**Handle Moves ... 67°**  
**Arm Moves ... 112°**

unit : mm

## Model : V120R, V120RB

\*Also available in Stainless Steel  
**Model : V120RSS, V120RBSS**  
 (Stainless steel models are supplied with stainless steel hex. bolt 1/4 BSW x 1 3/4")

V120R



V120RB

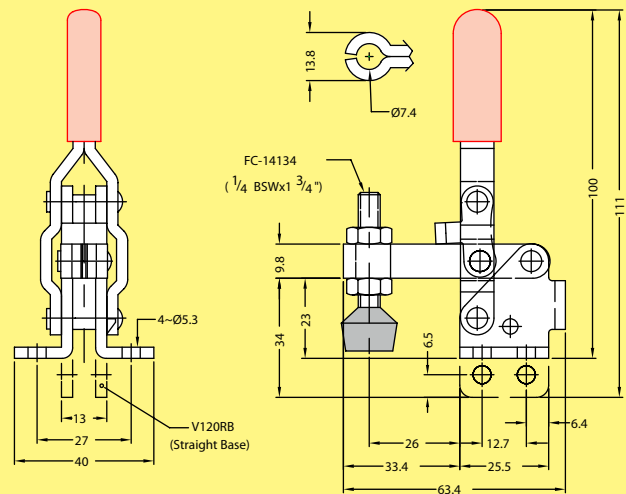

**Holding Capacity : 91kg MAX**  
**Weight : 158g**

**Handle Moves ... 60°**  
**Arm Moves ... 100°**

unit : mm

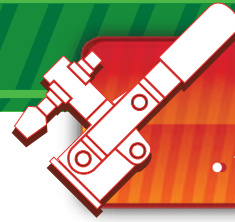

**VERTICAL  
HANDLE  
• TOGGLE CLAMP •**

**Model : V125**



**Holding Capacity : 177kg MAX**  
**Weight : 279g**

**Handle Moves ... 60°**  
**Arm Moves ... 100°**

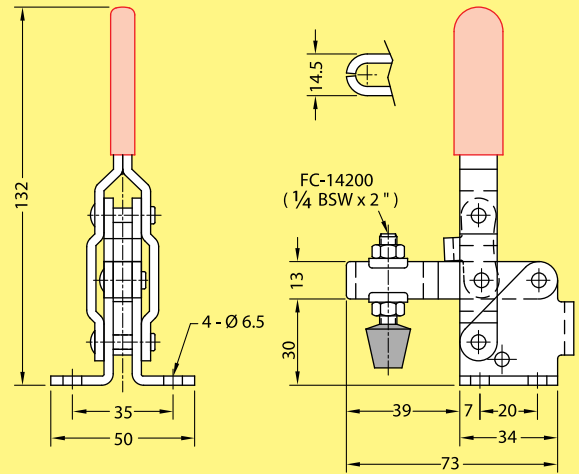

unit : mm

**Model : V125R**



**Holding Capacity : 177kg MAX**  
**Weight : 265g**

**Handle Moves ... 60°**  
**Arm Moves ... 100°**

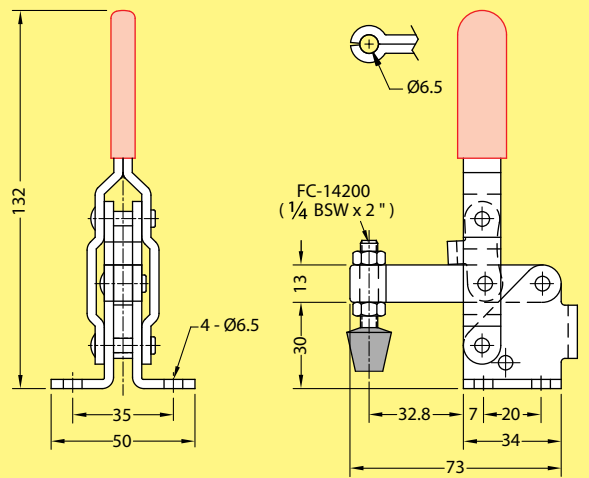

unit : mm

**Model : V130, V130L**

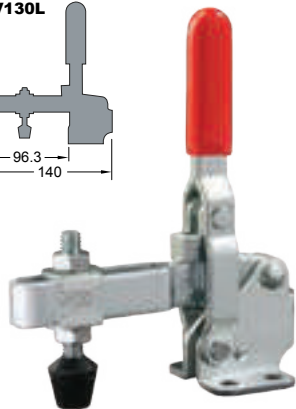
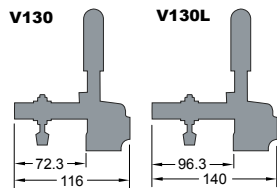

**Holding Capacity : 227kg MAX**  
**Weight : 364g, 381g**

**Handle Moves ... 60°**  
**Arm Moves ... 100°**

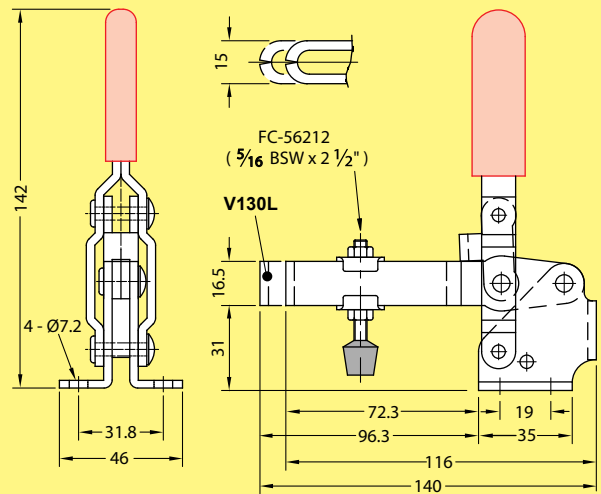

unit : mm

# VERTICAL HANDLE

• TOGGLE CLAMP •



## Model : V141, V141B

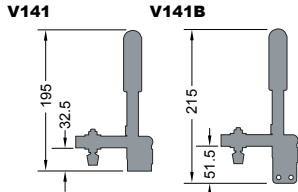

\*Also available in Stainless Steel  
**Model : V141SS, V141BSS**  
 (Stainless steel models are supplied with stainless steel hex. bolt 1/4 BSW x 1 3/4")

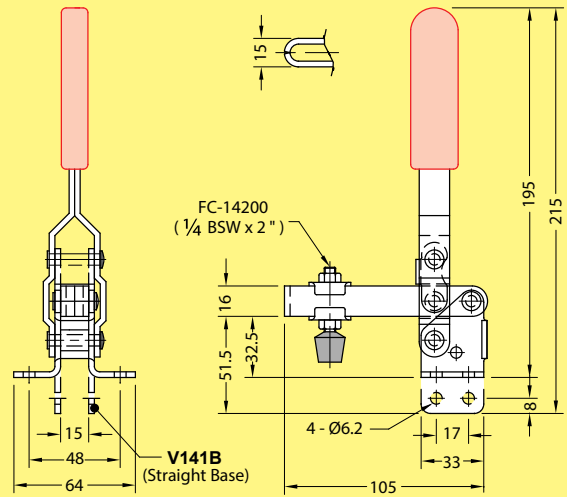
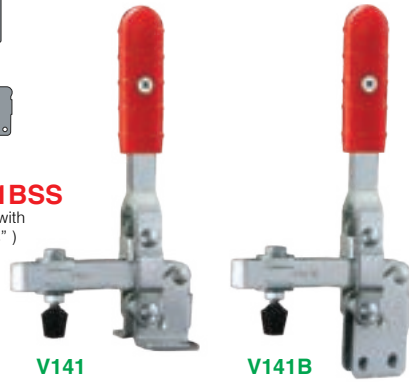

**Holding Capacity : 200kg MAX**  
**Weight : 412g, 412g**

**Handle Moves ... 64°**  
**Arm Moves ... 110°**

unit : mm

## Model : V150

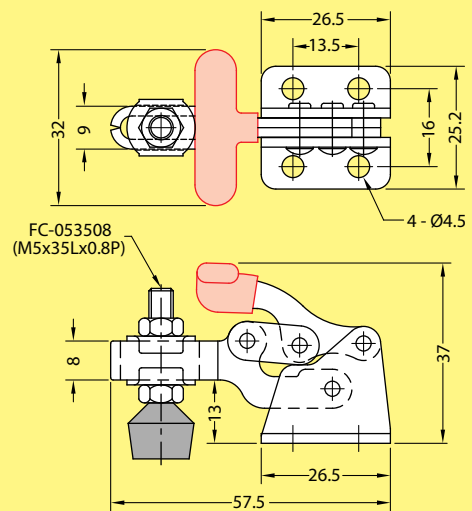

**Holding Capacity : 68kg MAX**  
**Weight : 63g**

**Handle Moves ... 175°**  
**Arm Moves ... 92°**

unit : mm

## Model : V160

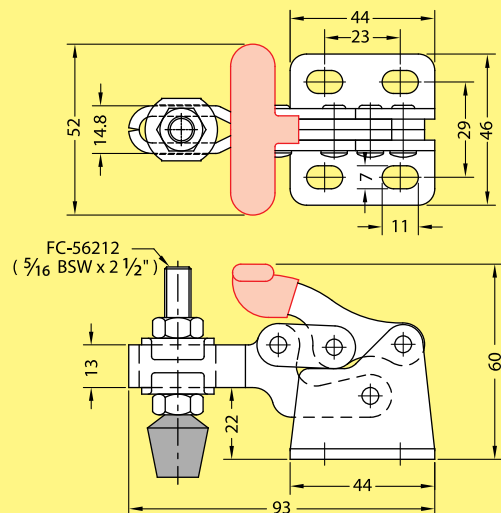

**Holding Capacity : 150kg MAX**  
**Weight : 269g**

**Handle Moves ... 175°**  
**Arm Moves ... 92°**

unit : mm



**VERTICAL  
HANDLE  
• TOGGLE CLAMP •**

**Model : V170**



**Holding Capacity : 320kg MAX**  
**Weight : 630g**

**Handle Moves ... 175°**  
**Arm Moves ... 92°**

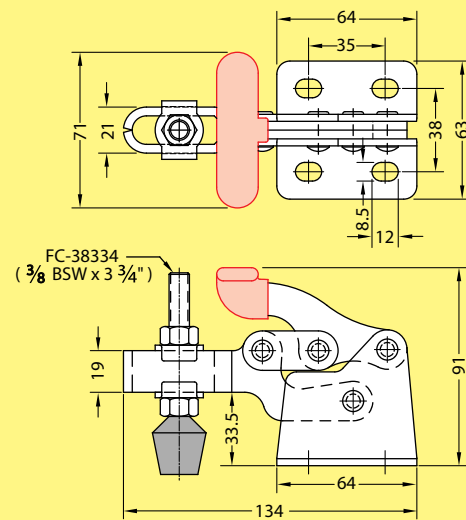

unit : mm

**Model : V210, V210B**

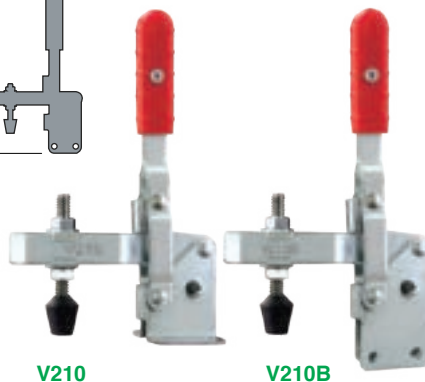
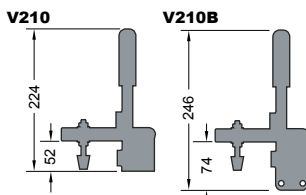

V210

V210B

**Holding Capacity : 340kg MAX**  
**Weight : 696g, 696g**

**Handle Moves ... 58°**  
**Arm Moves ... 105°**

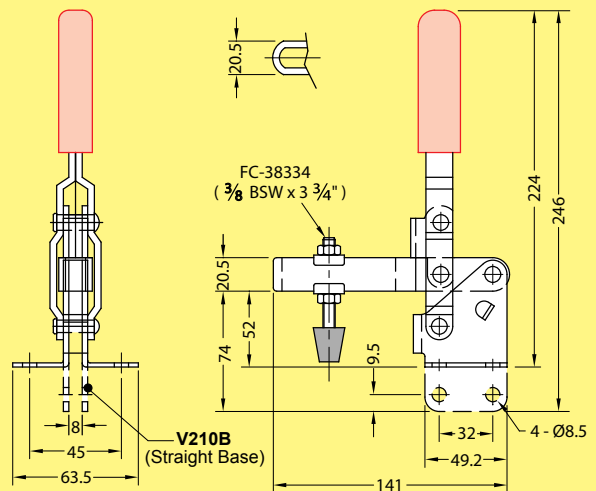

unit : mm

**Model : V310**



**Holding Capacity : 450kg MAX**  
**Weight : 1294g**

**Handle Moves ... 63°**  
**Arm Moves ... 101°**

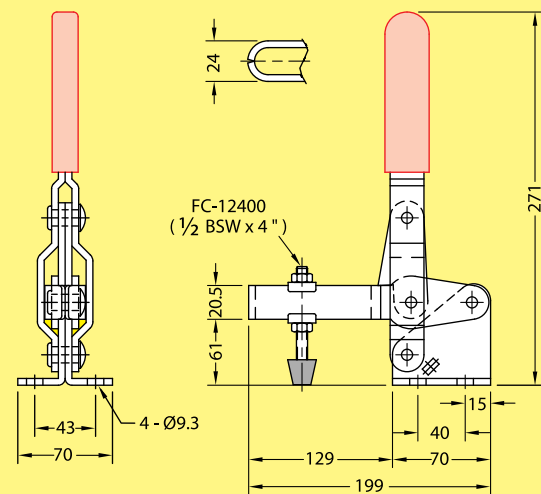

unit : mm

# VERTICAL HANDLE

• TOGGLE CLAMP •



# JSCLAMP

HIGH QUALITY TOGGLE CLAMP

Model	Description	Weight
V247U	U-Bar, Flanged Base	1345g
V247UB	U-Bar, Straight Base	1279g
V247S	Solid Bar, Flanged Base	1194g
V247SB	Solid Bar, Straight Base	1114g

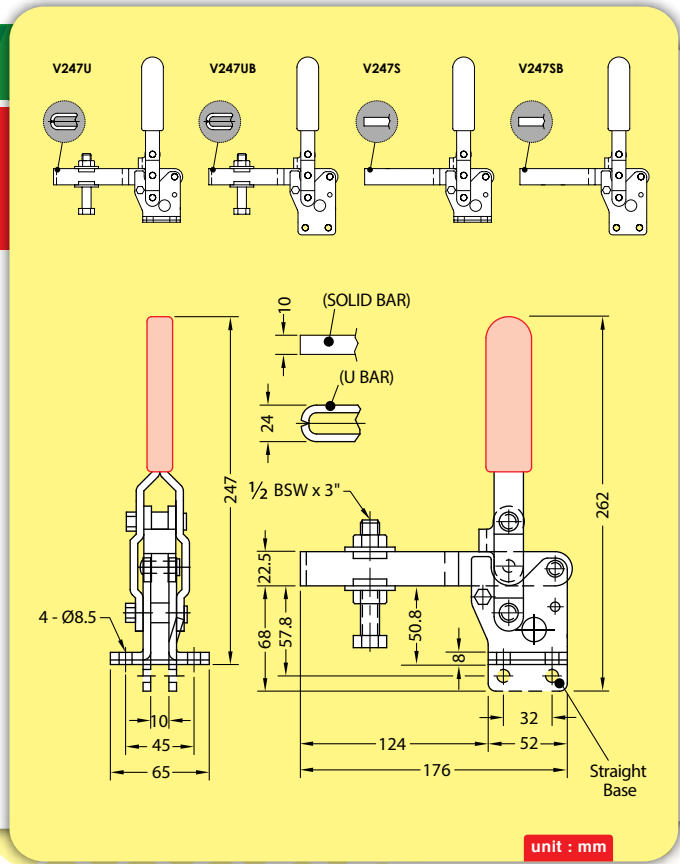
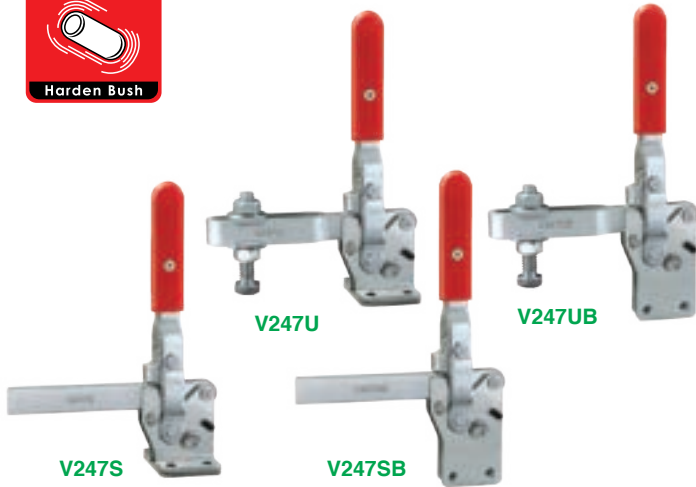

**Holding Capacity : 450kg MAX**

**Handle Moves ... 58°  
Arm Moves ... 100°**

**unit : mm**

## Usage



## Usage – Horizontal Handle

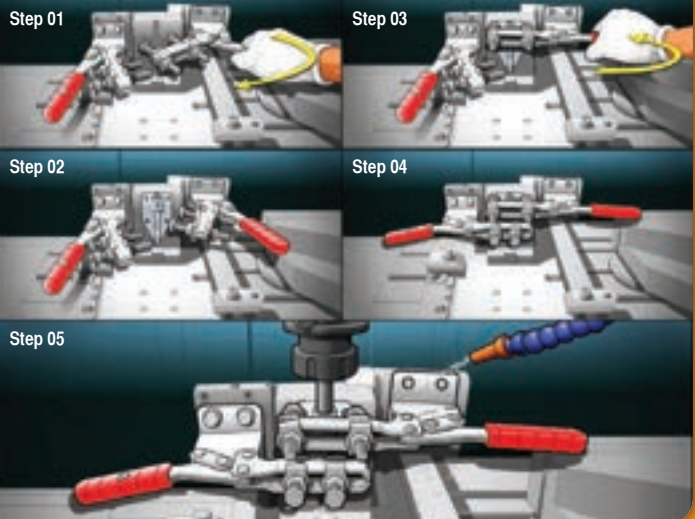

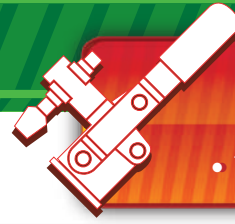

**VERTICAL  
HANDLE  
• TOGGLE CLAMP •**

**Model : V130B, V130BL**

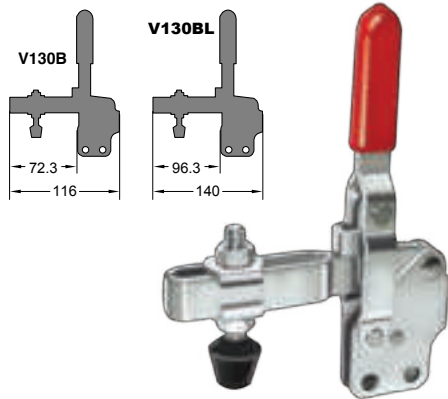

**Holding Capacity : 227kg MAX**  
**Weight : 365g, 379g**

**Handle Moves ... 60°**  
**Arm Moves ... 100°**

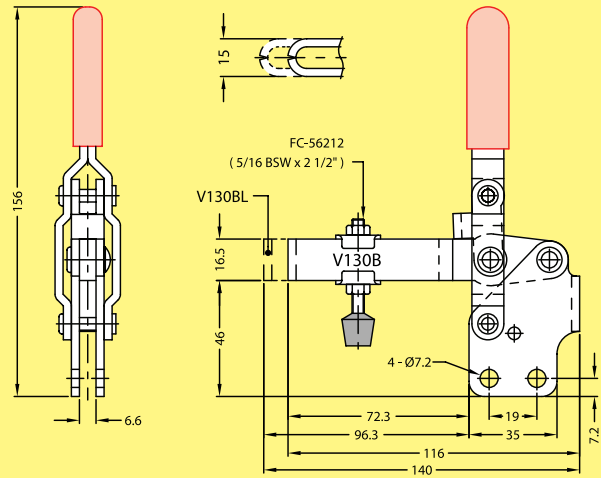

unit : mm

**Model : V130S, V130LS**

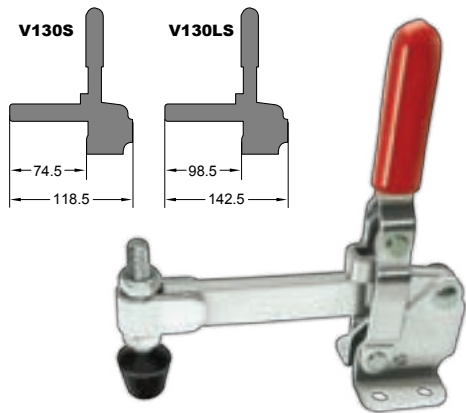

**Holding Capacity : 227kg MAX**  
**Weight : 372g, 388g**

**Handle Moves ... 60°**  
**Arm Moves ... 100°**

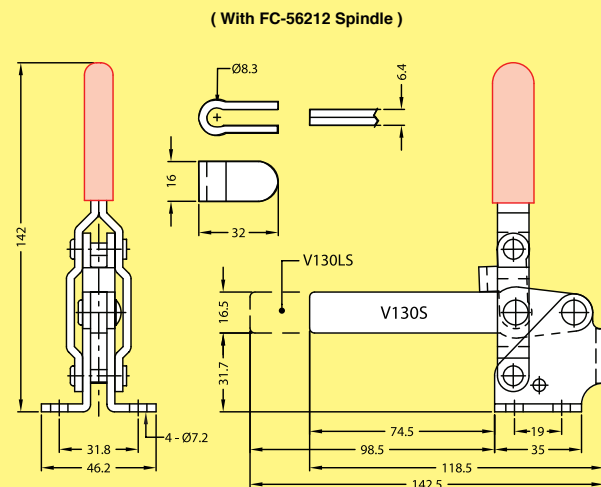

unit : mm

**Model : V130SB, V130LSB**

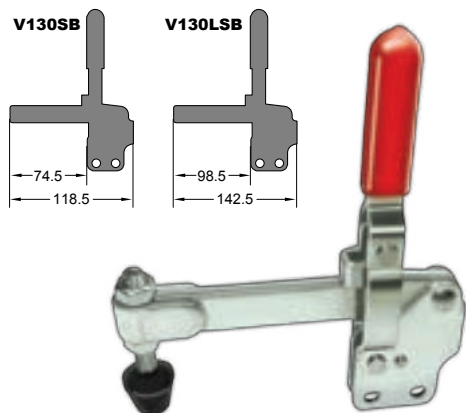

**Holding Capacity : 227kg MAX**  
**Weight : 369g, 394g**

**Handle Moves ... 60°**  
**Arm Moves ... 100°**

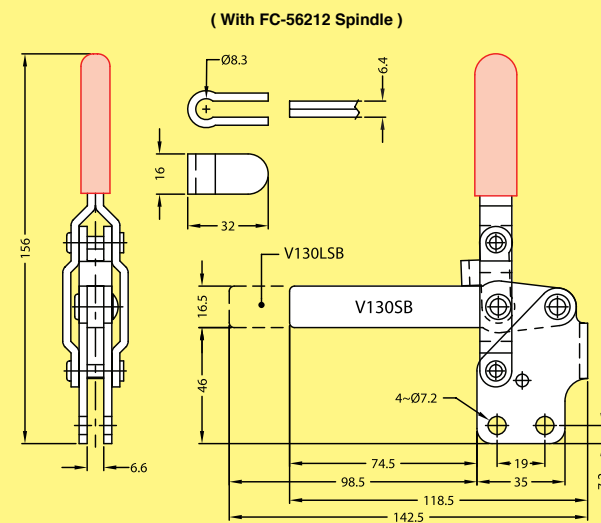

unit : mm

**VERTICAL HANDLE TOGGLE CLAMP**



**Model : V120, V120B**

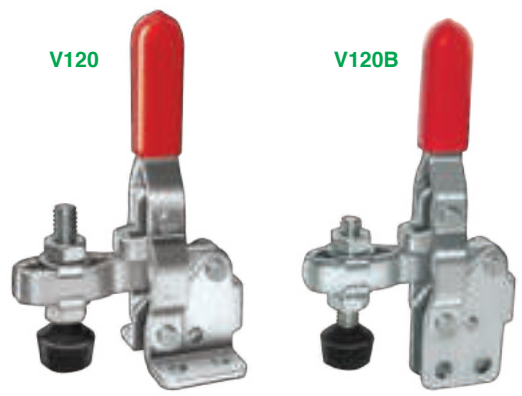

**Holding Capacity : 91kg MAX**  
**Weight : 160g, 160g**

**Handle Moves ... 60°**  
**Arm Moves ... 100°**

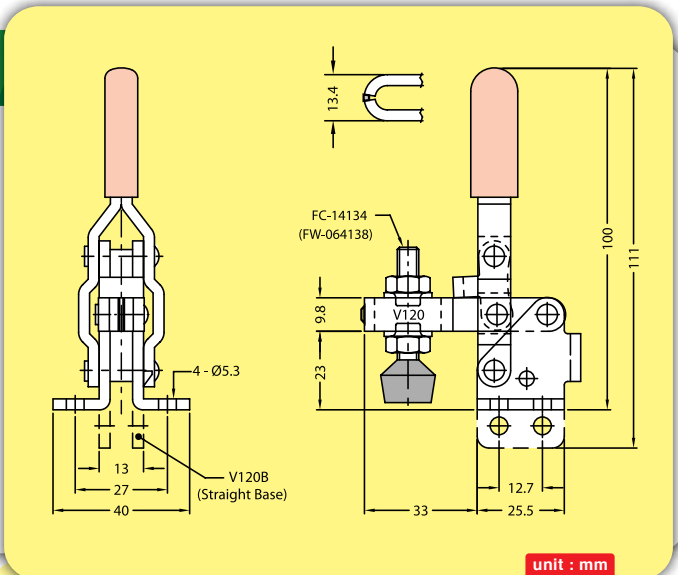

unit : mm

**Model : V142, V142B**

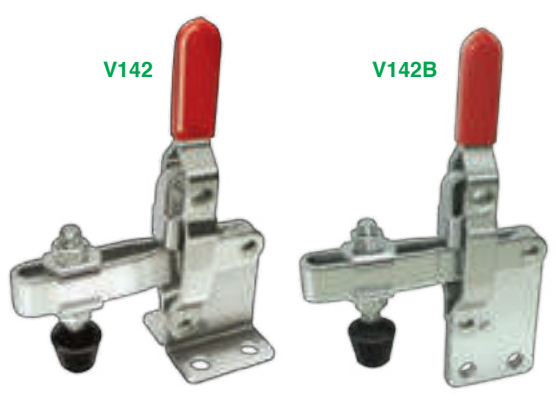

**Holding Capacity : 200kg MAX**  
**Weight : 370g, 370g**

**Handle Moves ... 56°**  
**Arm Moves ... 100°**

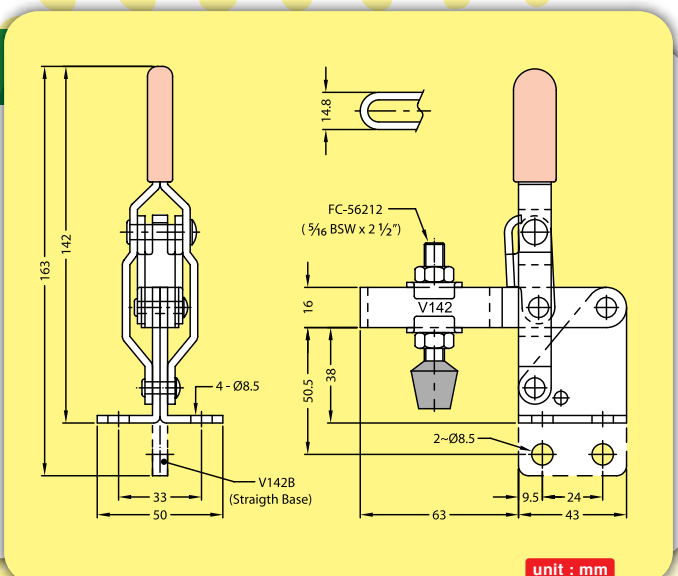

unit : mm

**Model : V208, V208B**

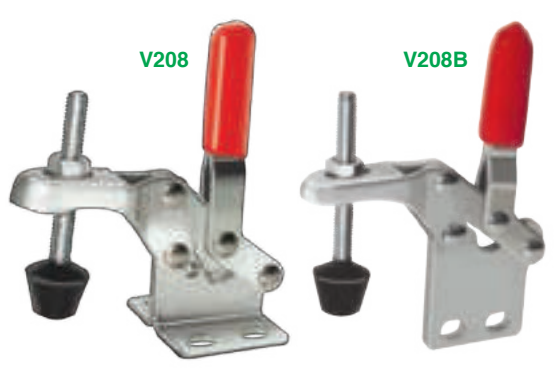

**Holding Capacity : 30kg MAX**  
**Weight : 48g, 48g**

**Handle Moves ... 100°**  
**Arm Moves ... 80°**

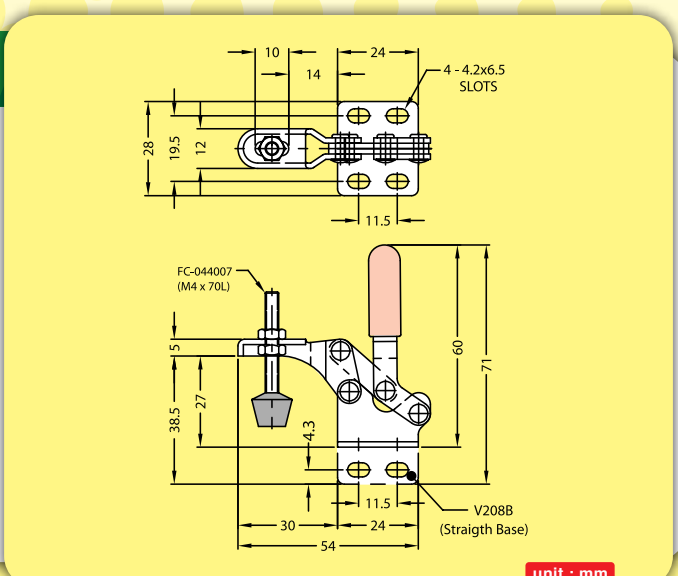

unit : mm



**Model : V145S**

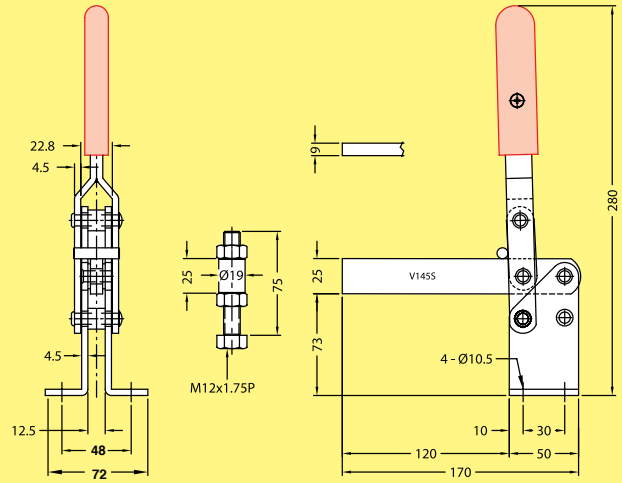

unit : mm

**Holding Capacity : 400kg MAX**  
**Weight : 1235g**

**Handle Moves ... 93°**  
**Arm Moves ... 170°**

**Model : V145SB**

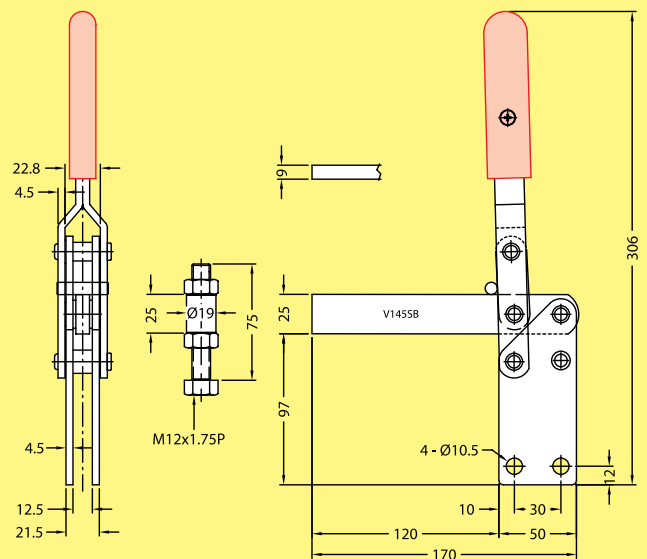

unit : mm

**Holding Capacity : 400kg MAX**  
**Weight : 1235g**

**Handle Moves ... 93°**  
**Arm Moves ... 170°**



**VERTICAL HANDLE**  
• TOGGLE CLAMP •



**Model : V145SB4**

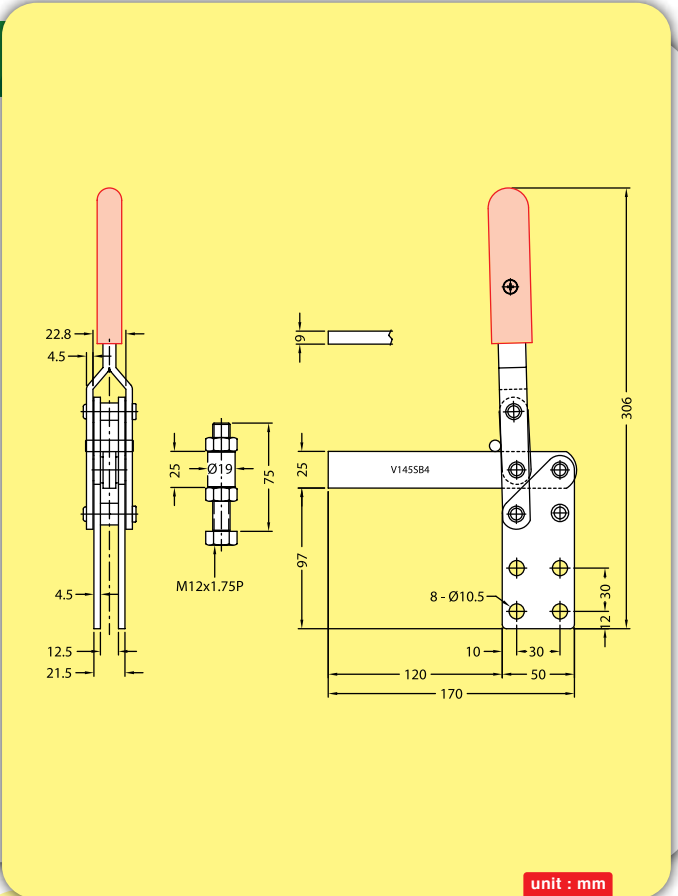

**Holding Capacity : 400kg MAX**  
**Weight :1213g**

**Handle Moves ... 93°**  
**Arm Moves ... 170°**

unit : mm

**Model : V145SBN**

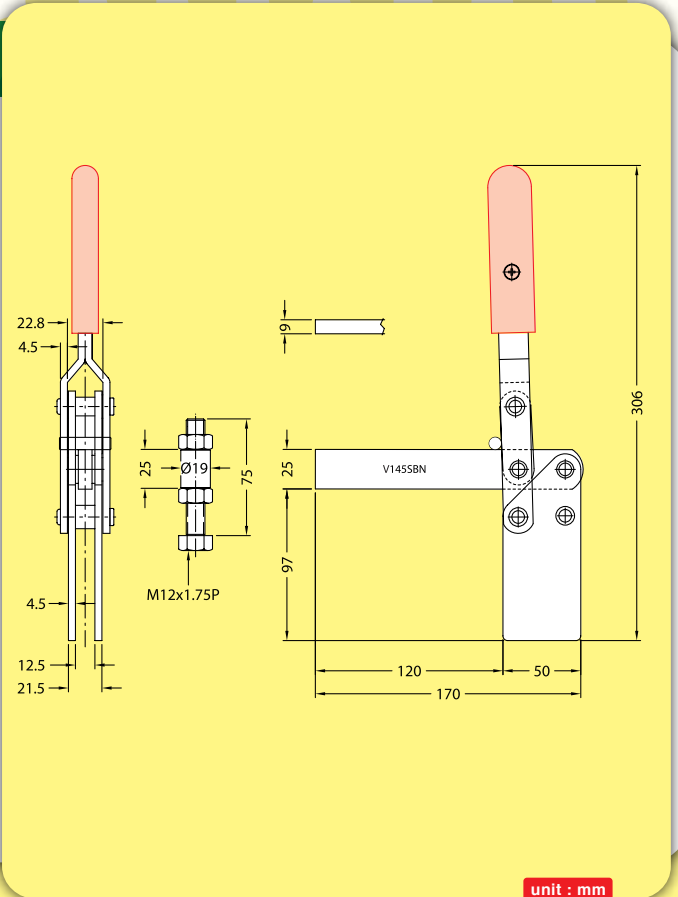

**Holding Capacity : 400kg MAX**  
**Weight :1252g**

**Handle Moves ... 93°**  
**Arm Moves ... 170°**

unit : mm

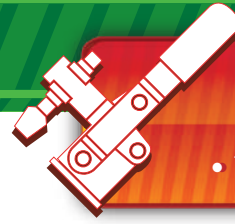

**VERTICAL  
HANDLE  
• TOGGLE CLAMP •**

**Model : V209, V209B**



V209

V209B

**Holding Capacity : 50kg MAX**  
**Weight : 56g**

**Handle Moves ... 100°**  
**Arm Moves ... 8°**

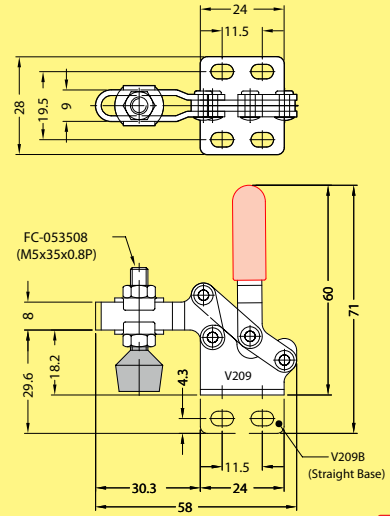

unit : mm

**Model : V210S, V210SB**



V210S

V210SB

**Holding Capacity : 340kg MAX**  
**Weight : 592g**

**Handle Moves ... 58°**  
**Arm Moves ... 105°**

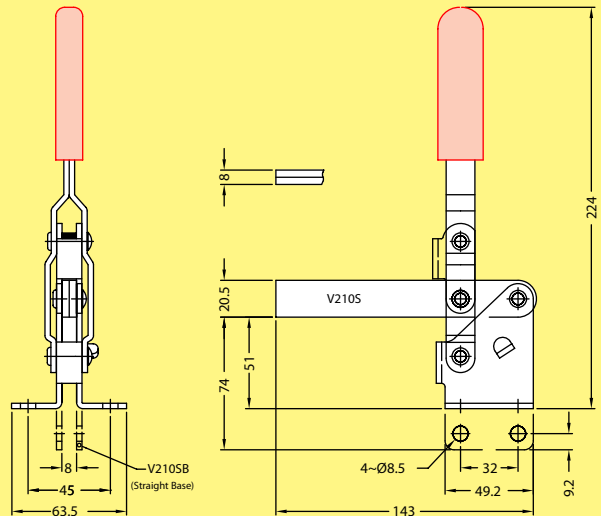

unit : mm

**Usage**



**Usage**



**PUSH / PULL  
TYPE**  
• TOGGLE CLAMP •



**Model : P102**



**Holding Capacity : 200kg MAX**  
**Weight : 381g**

**Handle Moves ... 150°**  
**Travel ... 30mm**

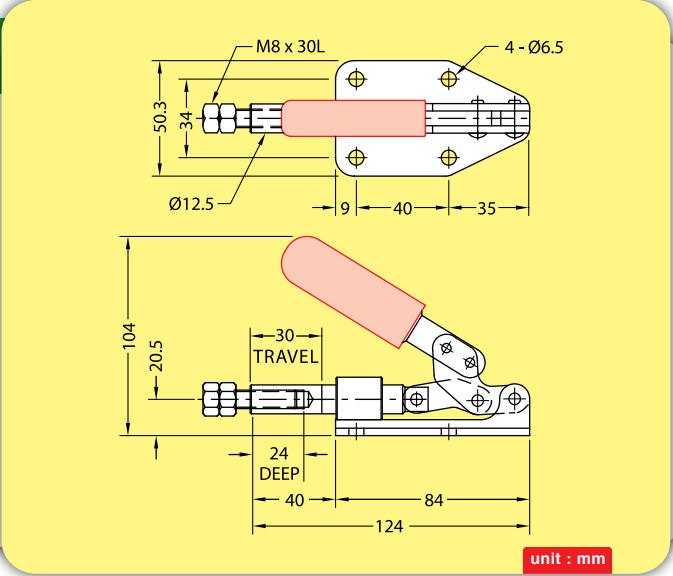

**Model : P115**

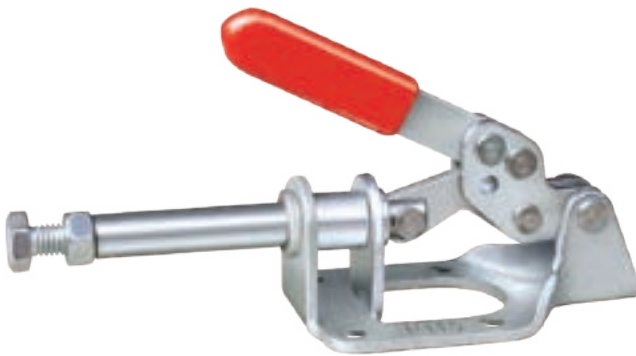

**Holding Capacity : 136kg MAX**  
**Weight : 310g**

**Handle Moves ... 180°**  
**Travel ... 32mm**

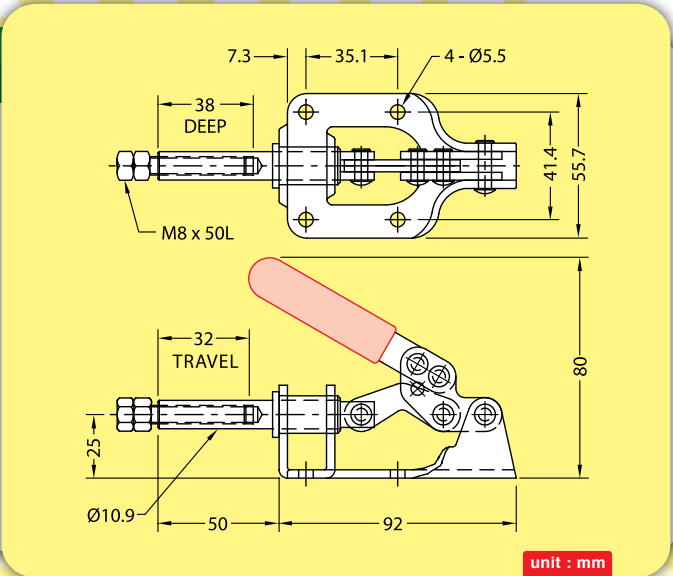

**Model : P125**



**Holding Capacity : 364kg MAX**  
**Weight : 875g**

**Handle Moves ... 180°**  
**Travel ... 41mm**

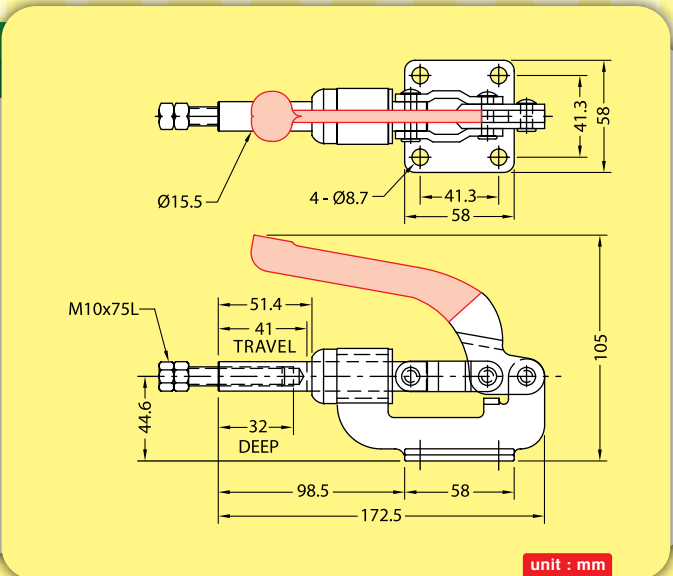



**PUSH / PULL  
TYPE  
• TOGGLE CLAMP •**

### Model : P130



\*Also available in Stainless Steel

**Model : P130SS**

(Stainless steel models are supplied with stainless steel hex. bolt M4 x 20L)

**Holding Capacity : 45kg MAX  
Weight : 44g**

**Handle Moves ... 190°  
Travel ... 17mm**

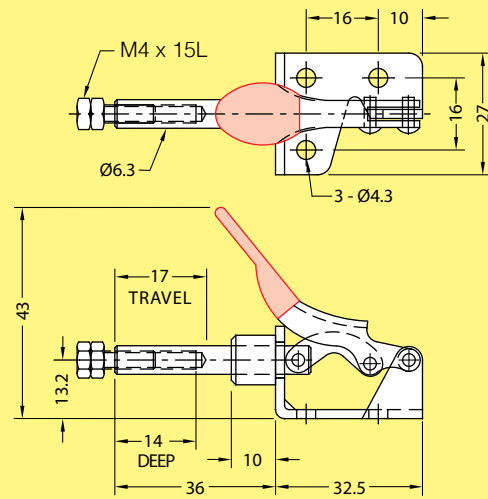

unit : mm

### Model : P150



**Holding Capacity : 200kg MAX  
Weight : 390g**

**Handle Moves ... 190°  
Travel ... 30mm**

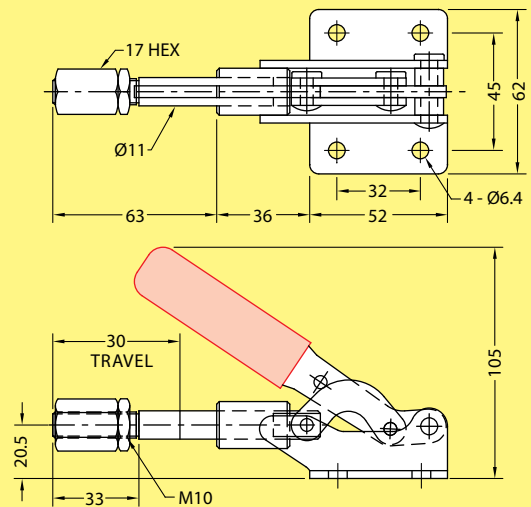

unit : mm

### Model : P152



**Holding Capacity : 454kg MAX  
Weight : 960g**

**Handle Moves ... 190°  
Travel ... 50mm**

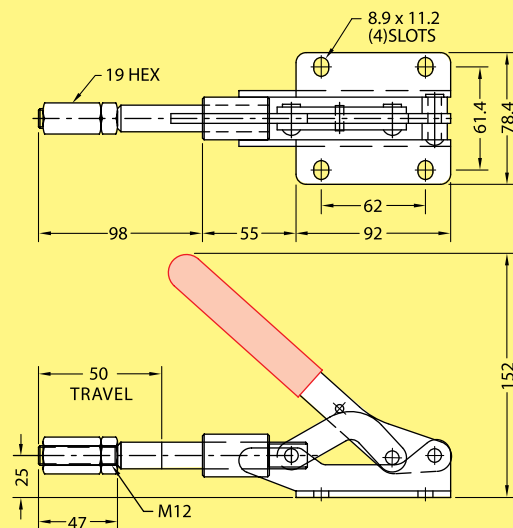

unit : mm

**PUSH / PULL  
TYPE  
• TOGGLE CLAMP •**



**Model : P107**

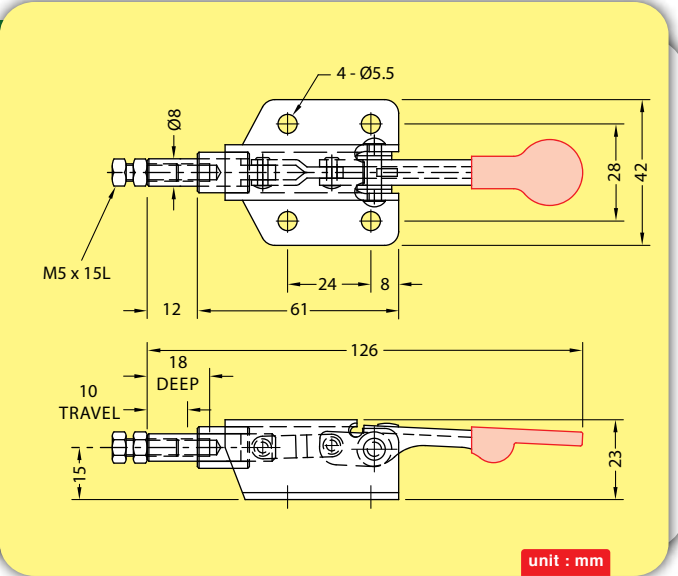

**Holding Capacity : 50kg MAX  
Weight : 101g**

**Handle Moves ... 66°  
Travel ... 10mm**

unit : mm

**Model : P154**

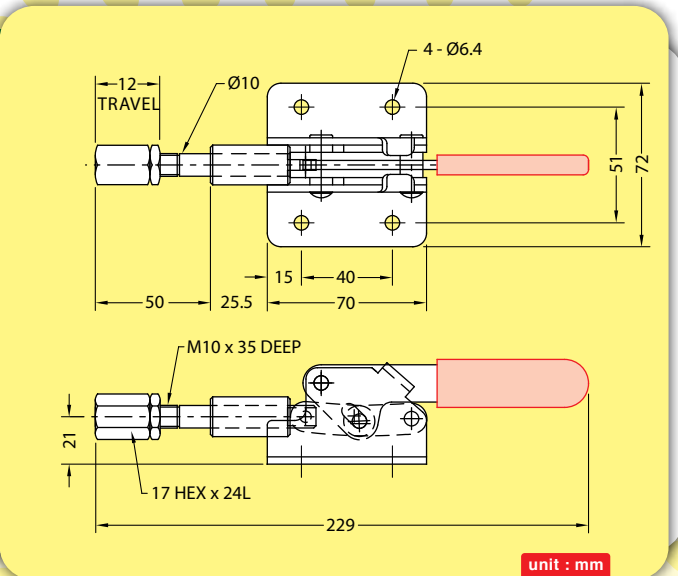

**Holding Capacity : 160kg MAX  
Weight : 496g**

**Handle Moves ... 45°  
Travel ... 15mm**

unit : mm

**Model : P156**

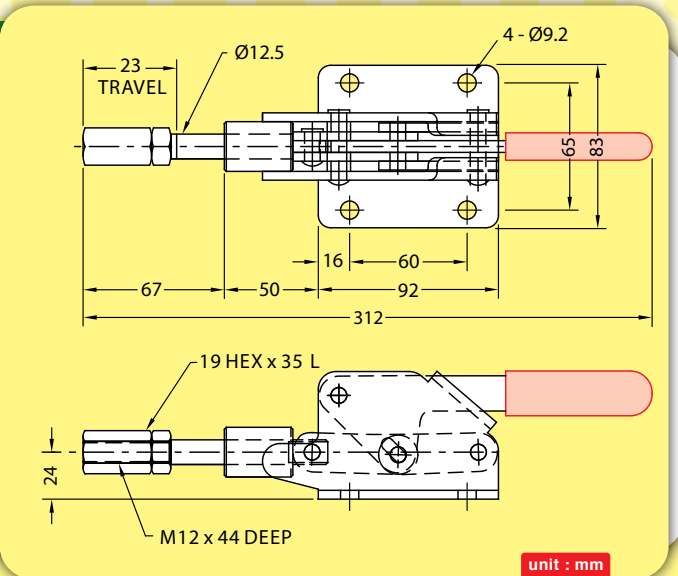

**Holding Capacity : 295kg MAX  
Weight : 1260g**

**Handle Moves ... 45°  
Travel ... 23mm**

unit : mm



**PUSH / PULL  
TYPE**  
• TOGGLE CLAMP •

### Model : P202



**Holding Capacity : 91kg MAX**  
**Weight : 130g**

**Handle Moves ... 180°**  
**Travel ... 19mm**

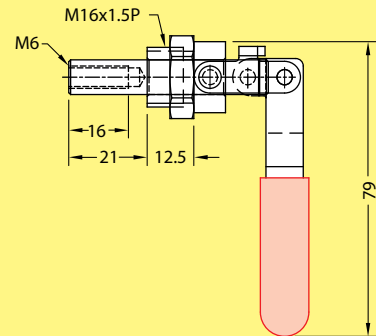
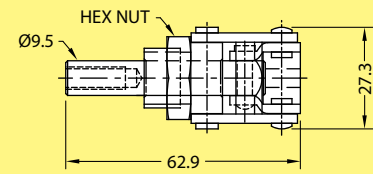

unit : mm

### Model : P204

\*Also available in Stainless Steel  
**Model : P204SS**



**Holding Capacity : 136kg MAX**  
**Weight : 291g**

**Handle Moves ... 180°**  
**Travel ... 38mm**

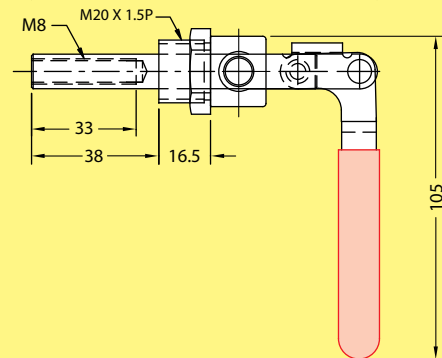
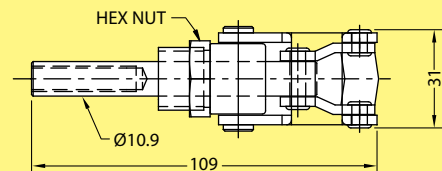

unit : mm

### Model : P206



**Holding Capacity : 136kg MAX**  
**Weight : 238g**

**Handle Moves ... 180°**  
**Travel ... 37.6mm**

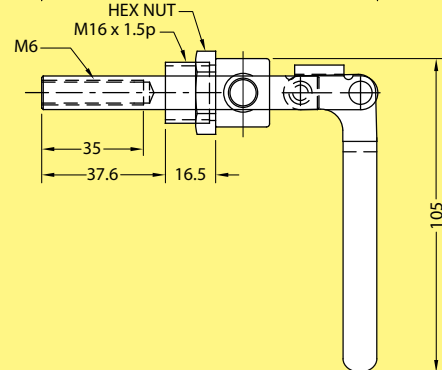
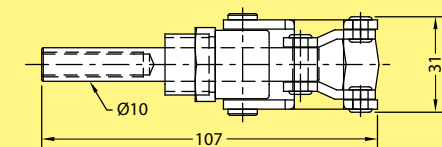

unit : mm

**PUSH / PULL  
TYPE  
• TOGGLE CLAMP •**



**Model : P208**



**Holding Capacity : 318kg MAX  
Weight : 767g**

**Handle Moves ... 180°  
Travel ... 67mm**

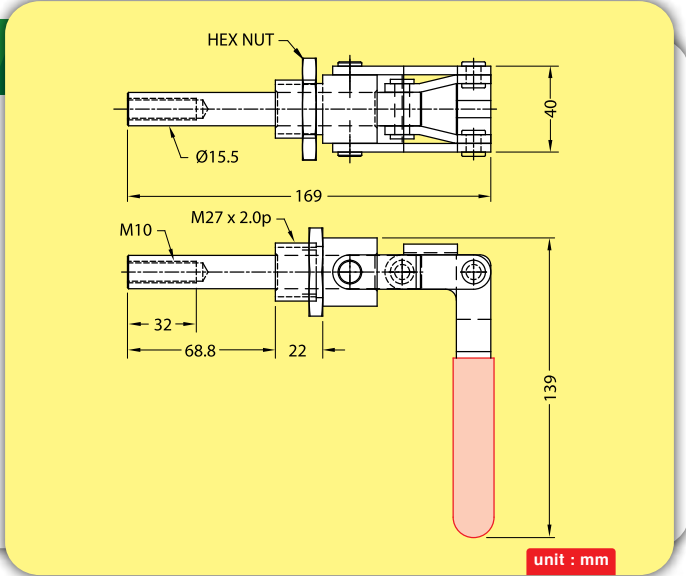

unit : mm

**Model : P340**



**Holding Capacity : 3000kg MAX  
Weight : 3100g**

**Handle Moves ... 180°  
Travel ... 101mm**

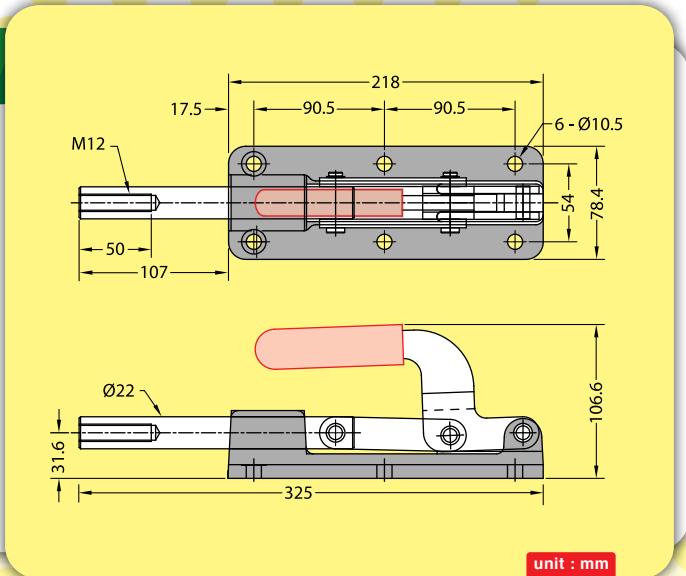

unit : mm

**Model : P105**



**Holding Capacity : 270kg MAX  
Weight : 585g**

**Handle Moves ... 150°  
Travel ... 28mm**

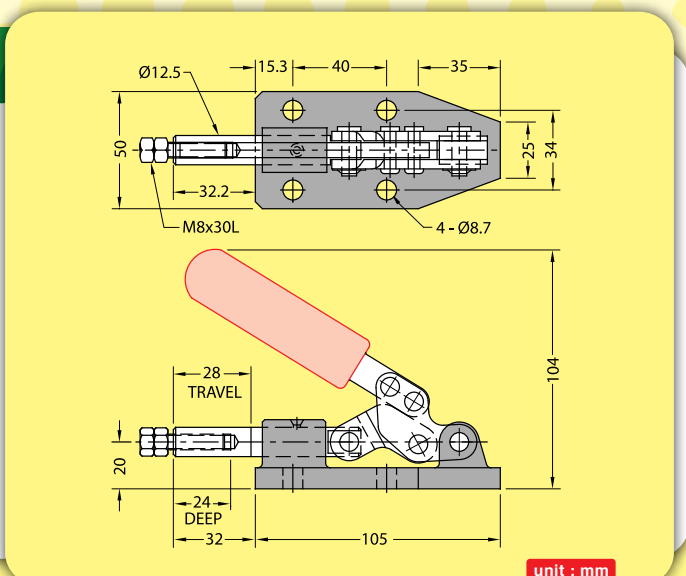

unit : mm



**PUSH / PULL  
TYPE  
• TOGGLE CLAMP •**

**Model : P100**



**Holding Capacity : 227kg MAX  
Weight : 388g**

**Handle Moves ... 180°  
Travel ... 32mm**

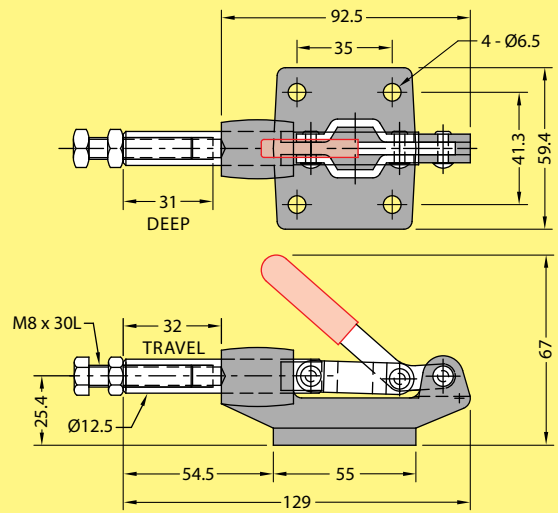

unit : mm

**Model : P109**

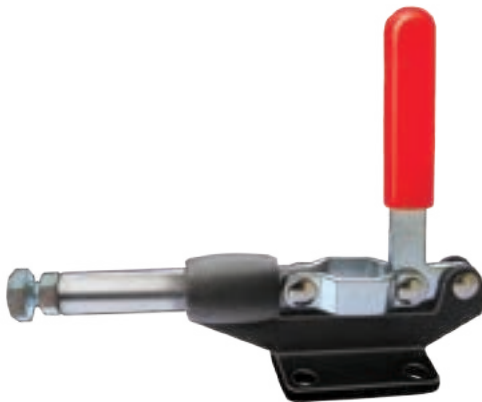

**Holding Capacity : 227kg MAX  
Weight : 377g**

**Handle Moves ... 180°  
Travel ... 32mm**

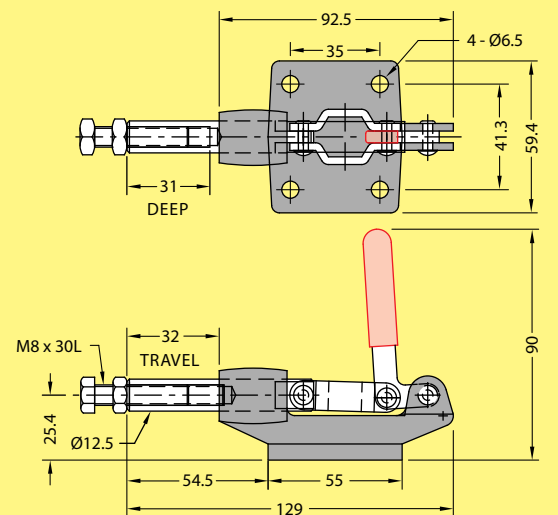

unit : mm

**Model : P200**



**Holding Capacity : 386kg MAX  
Weight : 620g**

**Handle Moves ... 180°  
Travel ... 42mm**

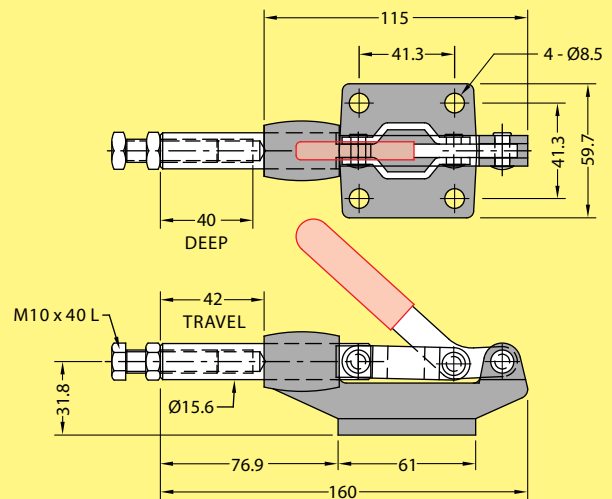

unit : mm



**PUSH / PULL  
TYPE  
• TOGGLE CLAMP •**



**Model : P209**

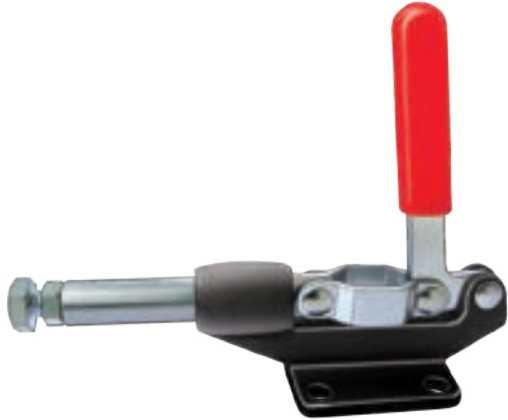

**Holding Capacity : 386kg MAX  
Weight : 625g**

**Handle Moves ... 180°  
Travel ... 42mm**

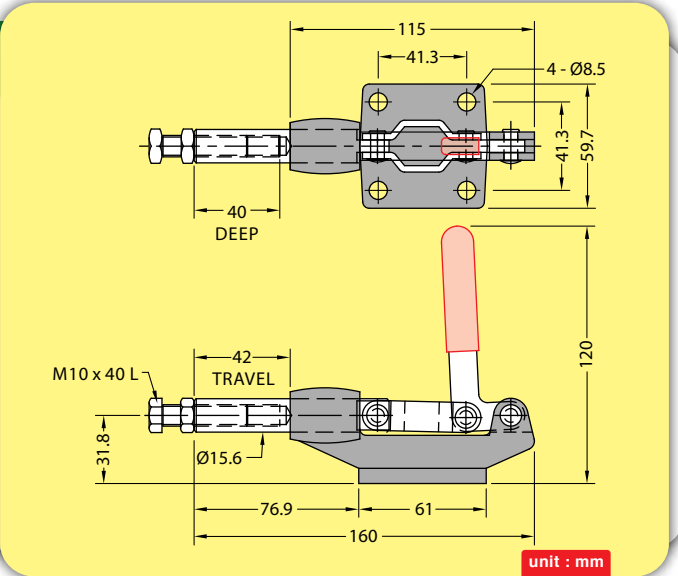

**Model : P300**



**Holding Capacity : 680kg MAX  
Weight : 1542g**

**Handle Moves ... 180°  
Travel ... 60mm**

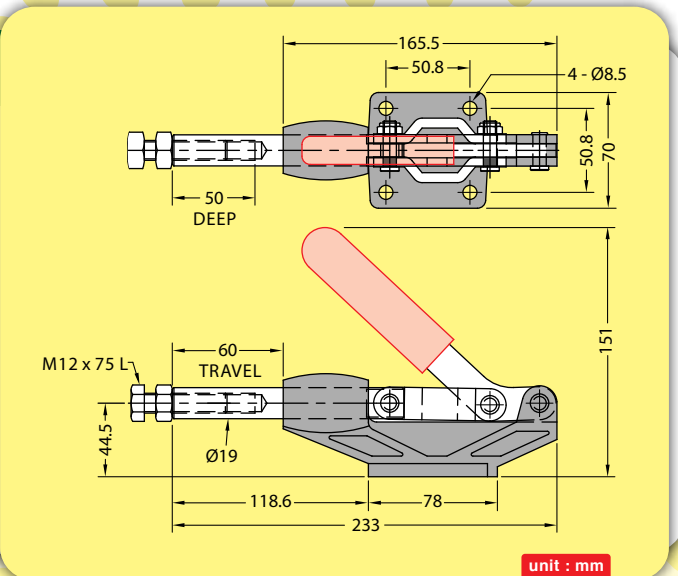

**Model : P309**



**Holding Capacity : 680kg MAX  
Weight : 1547g**

**Handle Moves ... 180°  
Travel ... 60mm**

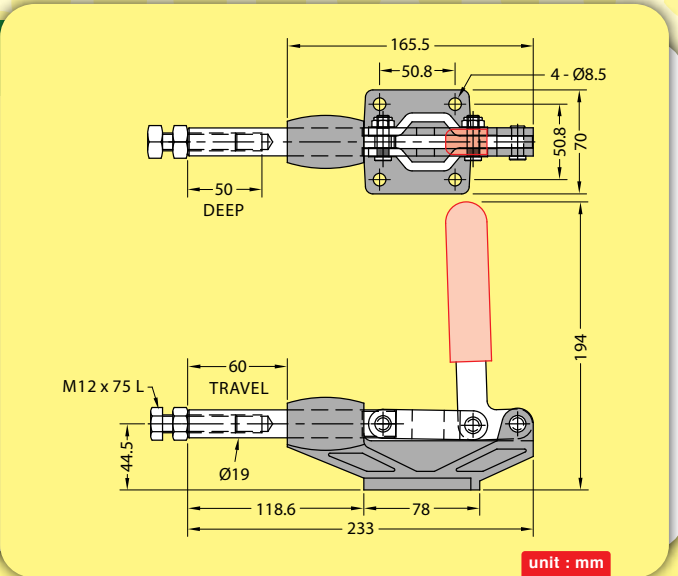



**PUSH / PULL  
TYPE**  
• TOGGLE CLAMP •

## Model : P102S



**Holding Capacity : 200kg MAX**  
**Weight : 376g**

**Handle Moves ... 150°**  
**Travel ... 30mm**

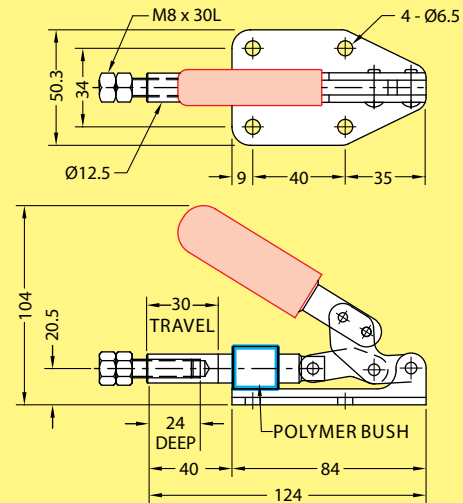

unit : mm



This toggle clamp is similar with P102 but it has longer life if compare with P102 and it is more smooth when doing the push and pull action on it. It is suitable to use in high frequency production because of its wear resistance and accuracy function and it is also suitable to use in clean room. This toggle clamp has very good performance in conducting welding job because it can release the welding carbon dirts automatically if worker forget to applying any oil on it.



**Resistance to dust and dirt**



**Maintenance free, dry running**



**Cost effective**



**High wear resistance**

## Usage



## Usage

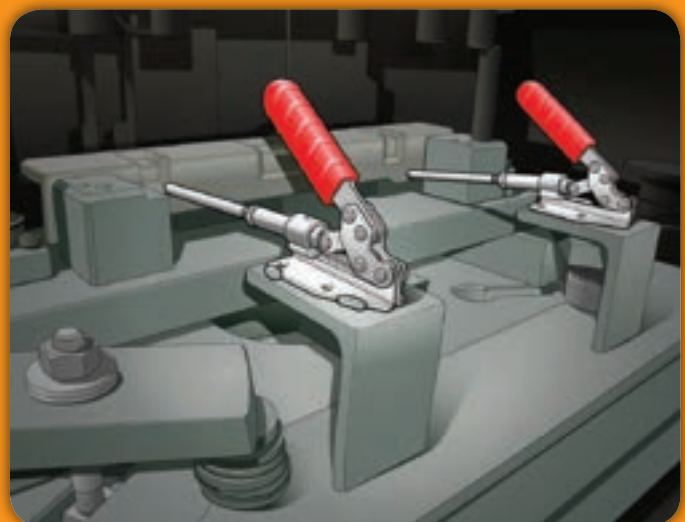

**PUSH / PULL  
TYPE  
• TOGGLE CLAMP •**



**Model : P122**

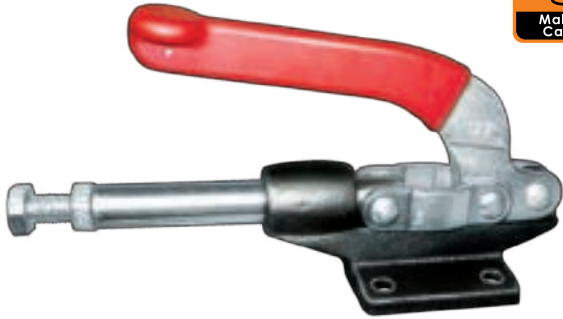

**Holding Capacity : 364kg MAX  
Weight : 809g**

**Handle Moves ... 180°  
Travel ... 41mm**

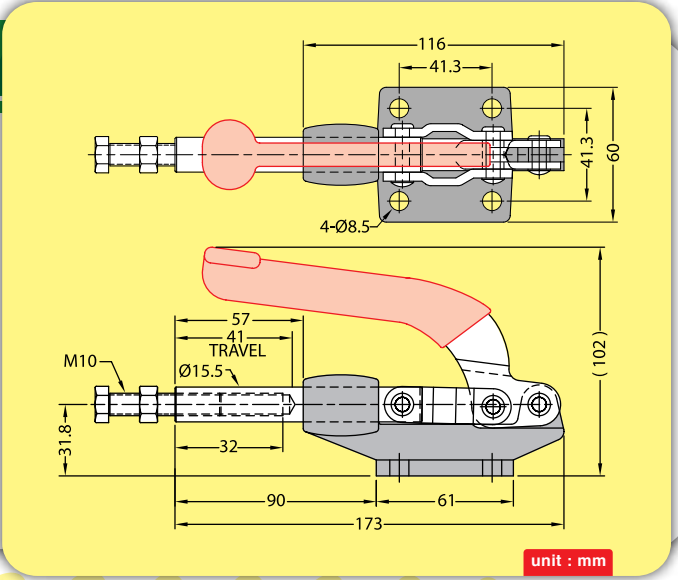

**Model : P320**



**Holding Capacity : 320kg MAX  
Weight : 710g**

**Handle Moves ... 180°  
Travel ... 41mm**

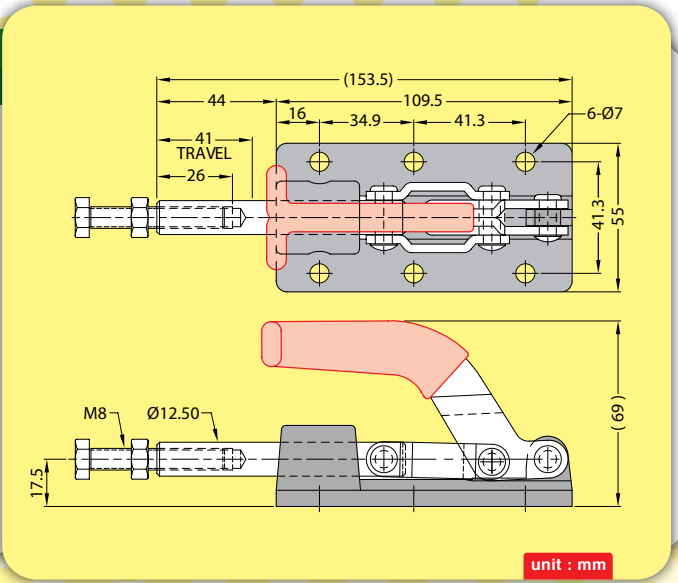

**Model : P330**



**Holding Capacity : 1136kg MAX  
Weight : 978g**

**Handle Moves ... 180°  
Travel ... 51mm**

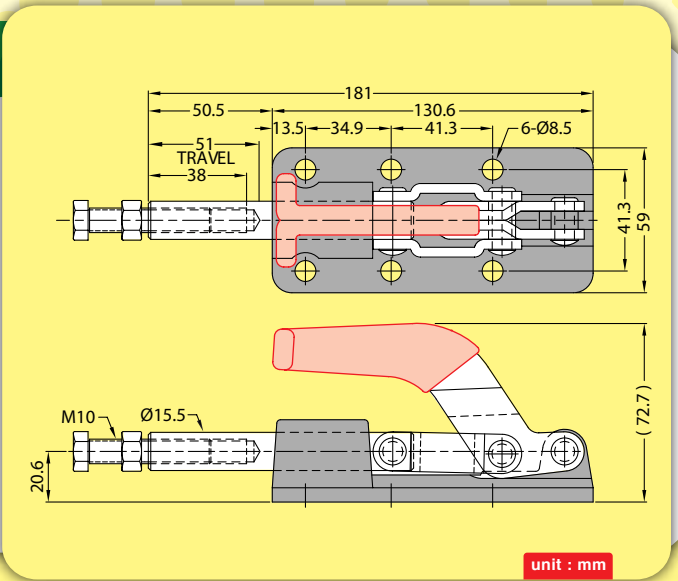



**PUSH / PULL  
TYPE  
• TOGGLE CLAMP •**

### Model : P560



**Holding Capacity : 600kg MAX**  
**Weight : 720g**

**Handle Moves ... 185°**  
**Travel ... 30mm**

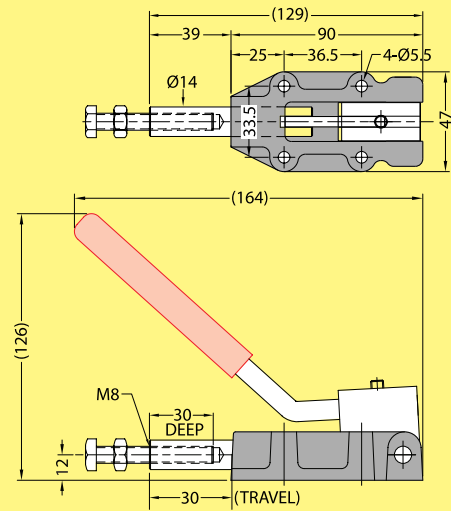

unit : mm

### Model : P570



**Holding Capacity : 1200kg MAX**  
**Weight : 1800g**

**Handle Moves ... 185°**  
**Travel ... 51mm**

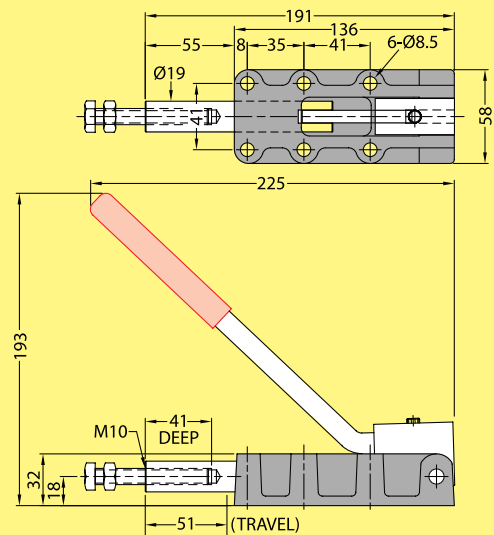

unit : mm

### Model : P580



**Holding Capacity : 2500kg MAX**  
**Weight : 4281g**

**Handle Moves ... 185°**  
**Travel ... 78mm**

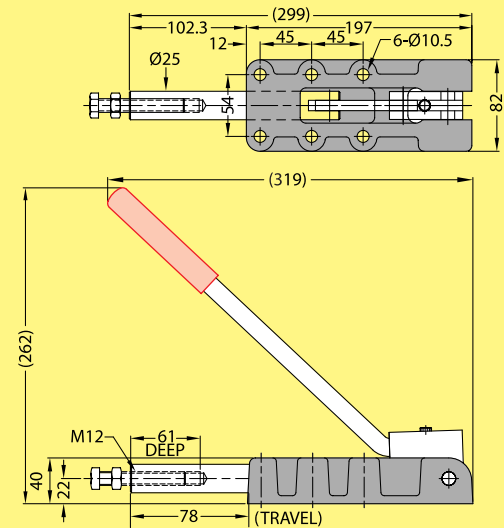

unit : mm

**PUSH / PULL  
TYPE  
• TOGGLE CLAMP •**



**Model : P610**

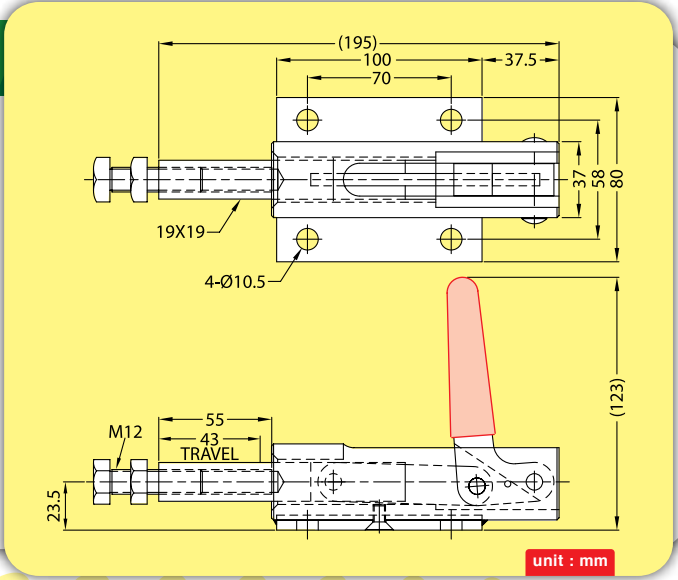
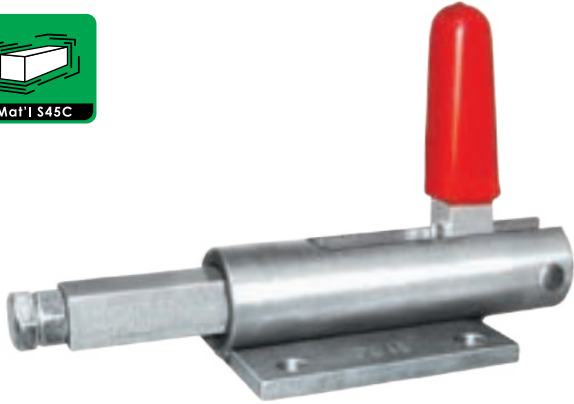

**Holding Capacity : 300kg MAX  
Weight : 1661g**

**Handle Moves ... 115°  
Travel ... 43mm**

unit : mm

**Model : P620**

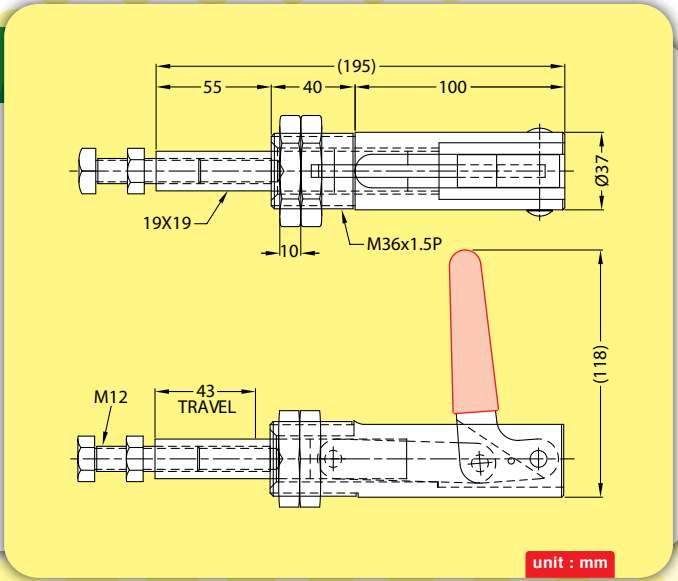
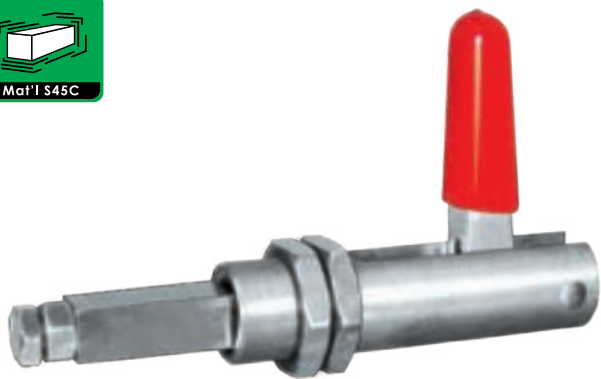

**Holding Capacity : 300kg MAX  
Weight : 1281g**

**Handle Moves ... 115°  
Travel ... 43mm**

unit : mm

**Model : P625**

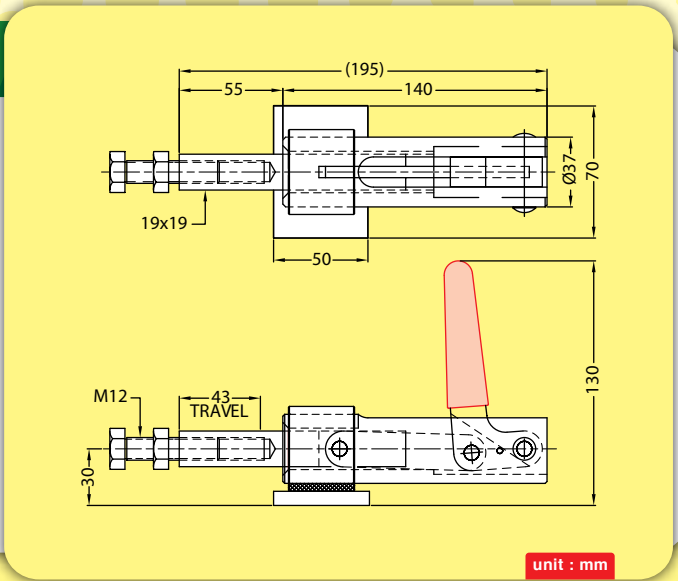
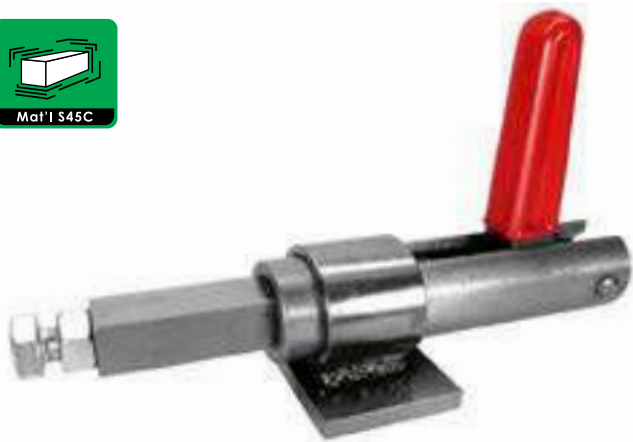

**Holding Capacity : 300kg MAX  
Weight : 1580g**

**Handle Moves ... 115°  
Travel ... 43mm**

unit : mm



**PUSH / PULL  
TYPE  
• TOGGLE CLAMP •**

**Model : P106**

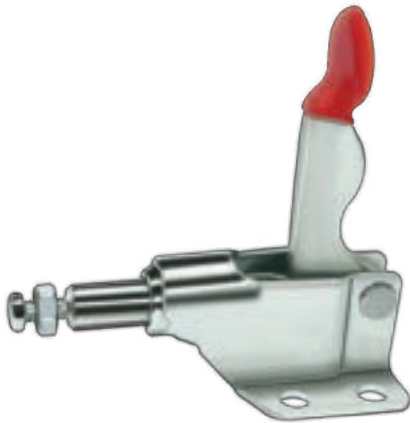

**Holding Capacity : 50 kg MAX  
Weight : 70g**

**Handle Moves ... 93°  
Travel ... 13mm**

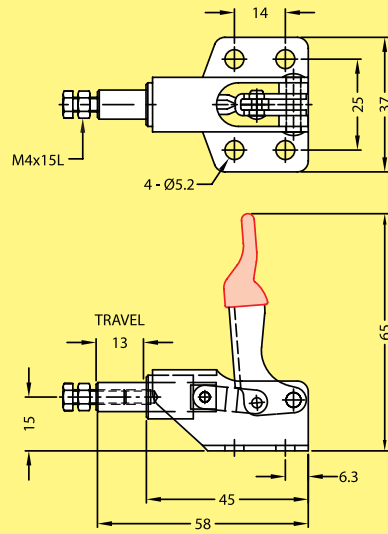

unit : mm

**Model : P118**

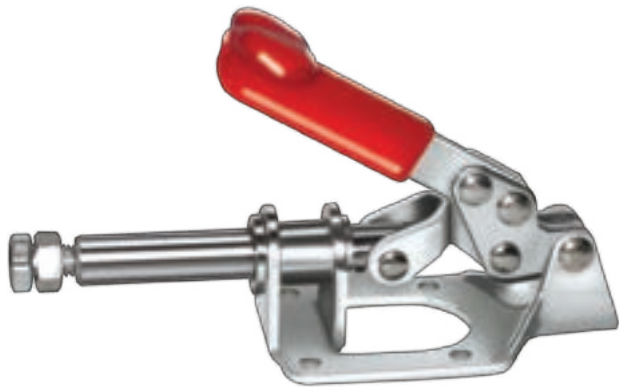

**Holding Capacity : 110 kg MAX  
Weight : 148g**

**Handle Moves ... 150°  
Travel ... 25mm**

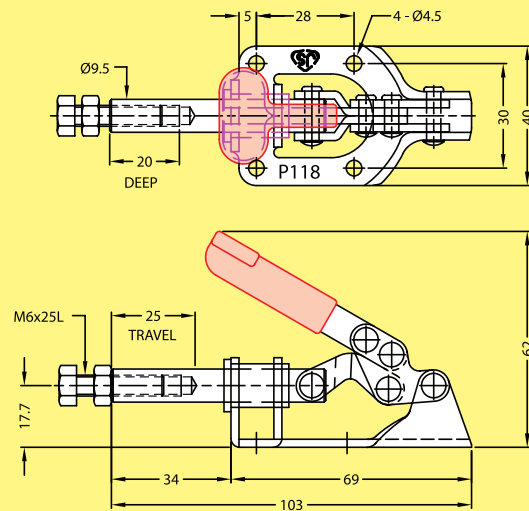

unit : mm

**Model : P170**



**Holding Capacity : 227 kg MAX  
Weight : 411g**

**Handle Moves ... 180°  
Travel ... 32mm**

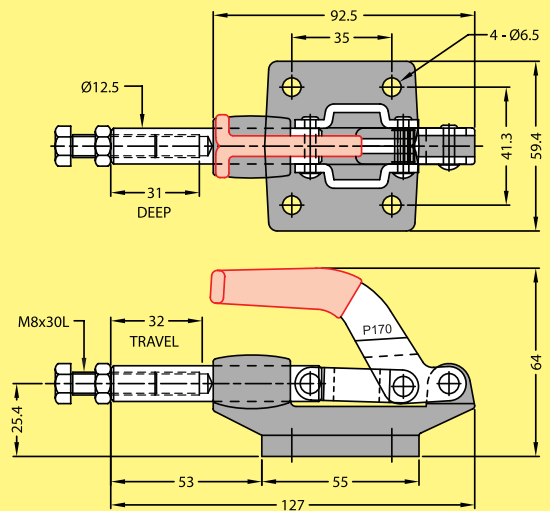

unit : mm

**PUSH / PULL  
TYPE**  
• TOGGLE CLAMP •

**Model : P110LH, P110RH**



**Holding Capacity : 80kg MAX**  
**Weight : 56g**

**Handle Moves ... 180°**  
**Travel ... 16mm**

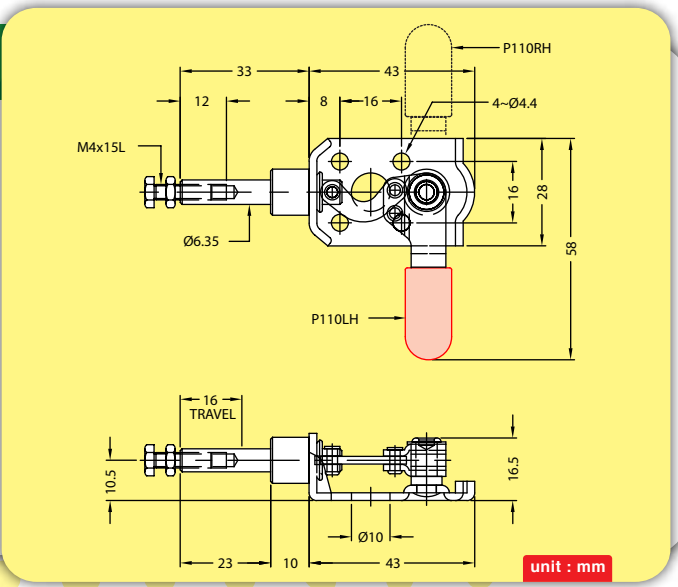

**Model : P120**



**Holding Capacity : 220kg MAX**  
**Weight : 500g**

**Handle Moves ... 180°**  
**Travel ... 43mm**

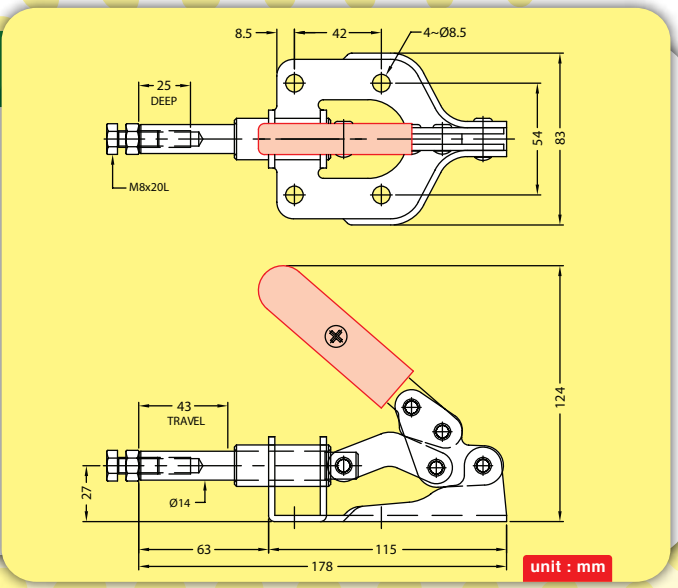

**Model : P600**



**Holding Capacity : 300 kg MAX**  
**Weight : 674g**

**Handle Moves ... 76°**  
**Travel ... 30mm**

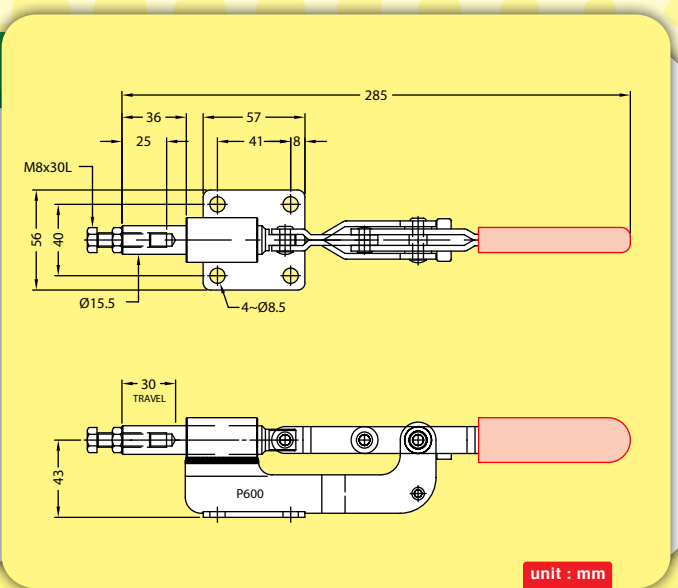



**PUSH / PULL  
TYPE  
• TOGGLE CLAMP •**

### Model : P710



**Holding Capacity : 350kg MAX  
Weight : 670g**

**Handle Moves...90°**

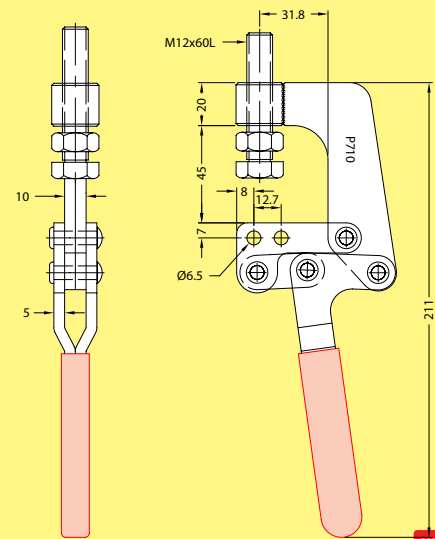

unit : mm

### Model : P720



**Holding Capacity : 350kg MAX  
Weight : 725g**

**Handle Moves...90°**

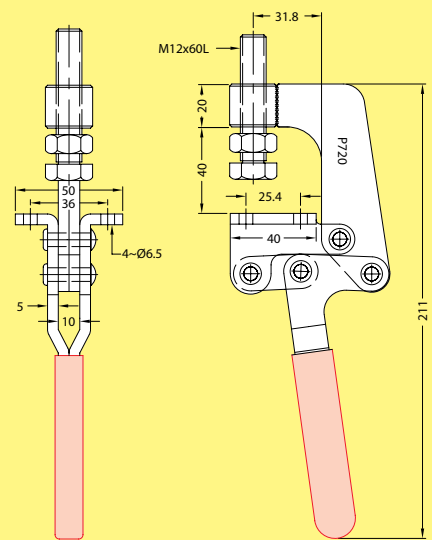

unit : mm

### Model : P630



**Holding Capacity : 1600 kg MAX  
Weight : 4690g**

**Handle Moves ... 180°  
Travel ... 76mm**

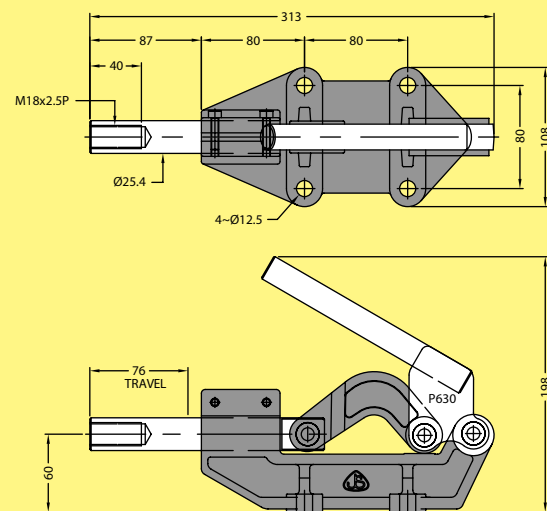

unit : mm



**PUSH / PULL  
TYPE**  
• TOGGLE CLAMP •



**Model : P116**

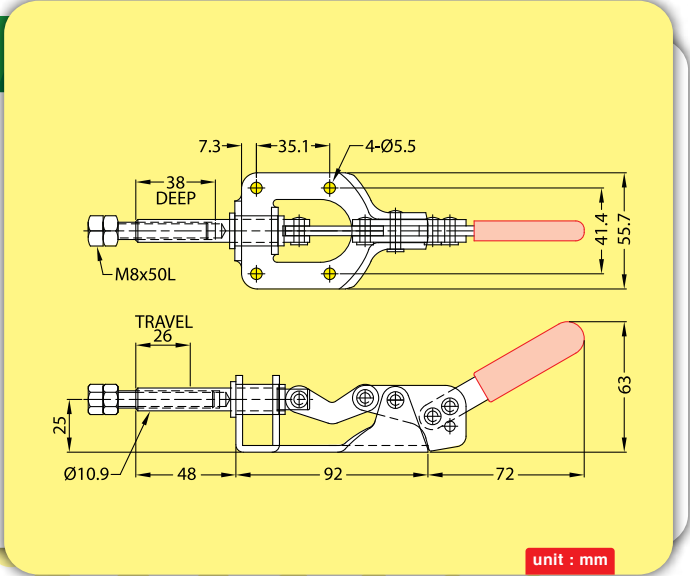
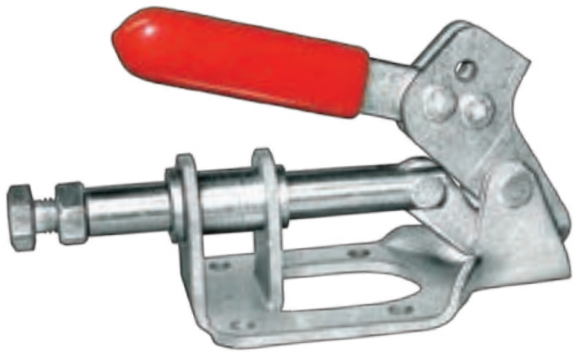

**Holding Capacity : 136kg MAX**  
**Weight : 323g**

**Handle Moves ... 135°**  
**Travel ... 26mm**

unit : mm

**Usage**

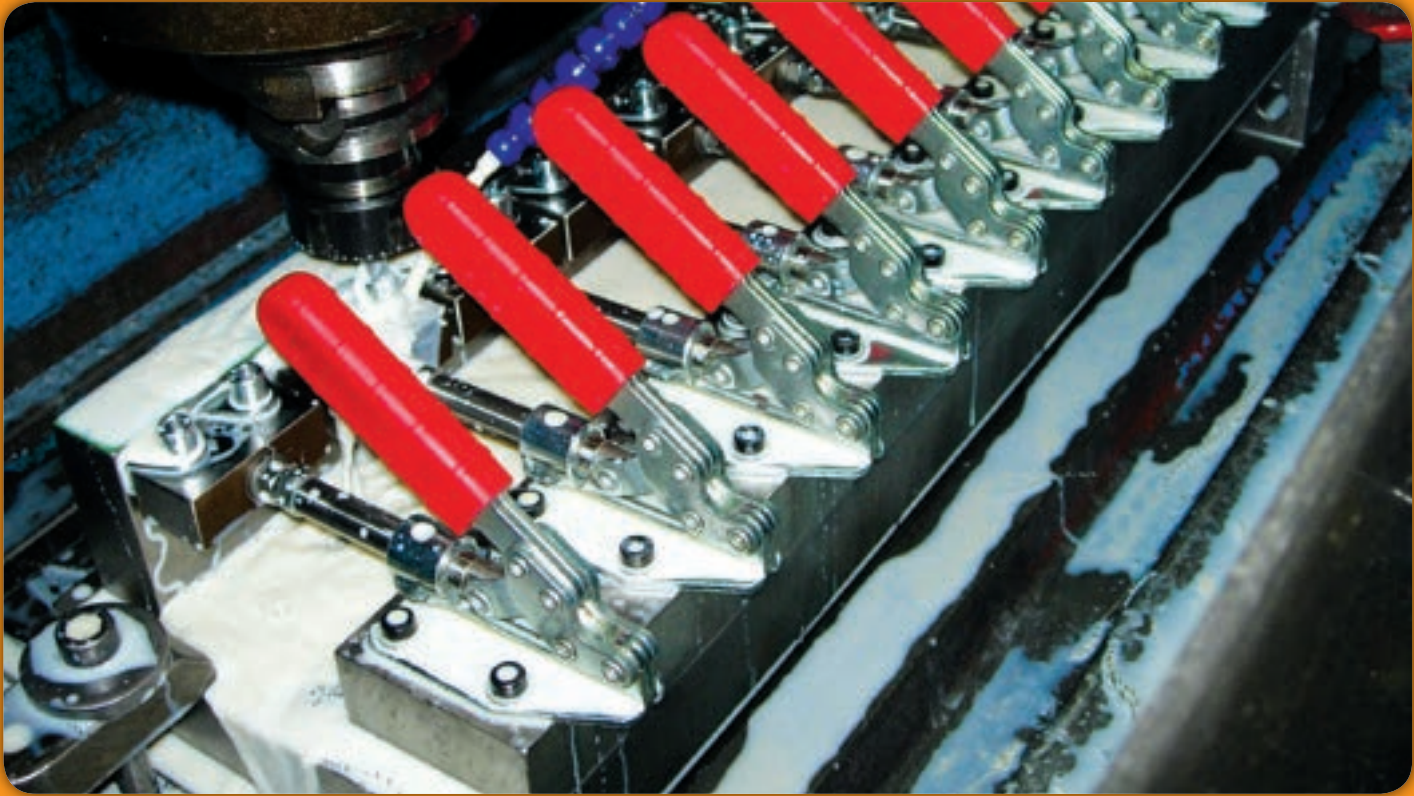



**LATCH TYPE**  
• TOGGLE CLAMP •

### Model : L130

\*Also available in Stainless Steel  
**Model : L130SS**



**Holding Capacity : 164kg MAX**

**Weight : 81g**

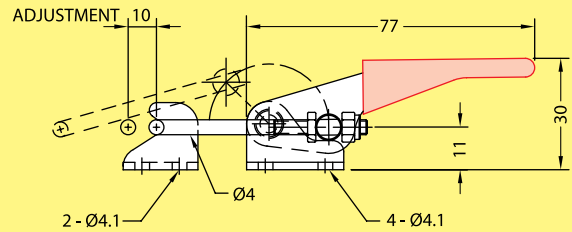
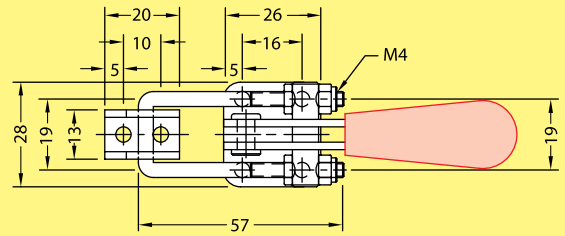

unit : mm

### Model : L1305

\*Also available in Stainless Steel  
**Model : L1305SS**



**Holding Capacity : 225kg MAX**

**Weight : 96g**

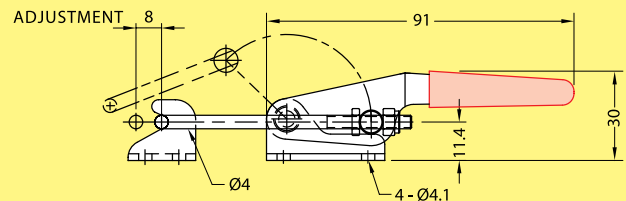
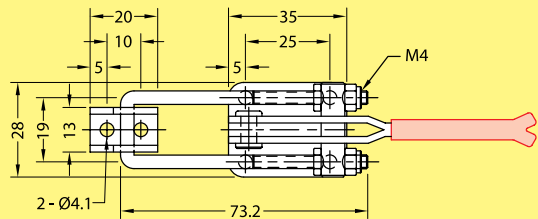

unit : mm

### Model : L131

\*Also available in Stainless Steel  
**Model : L131SS**



**Holding Capacity : 318kg MAX**

**Weight : 234g**

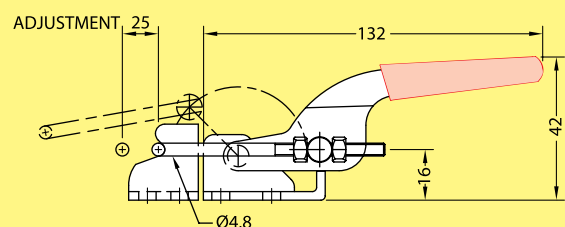
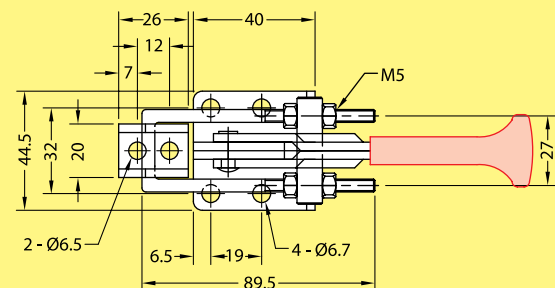

unit : mm

**LATCH TYPE**  
• TOGGLE CLAMP •



**Model : L1315**

\*Also available in Stainless Steel  
**Model : L1315SS**

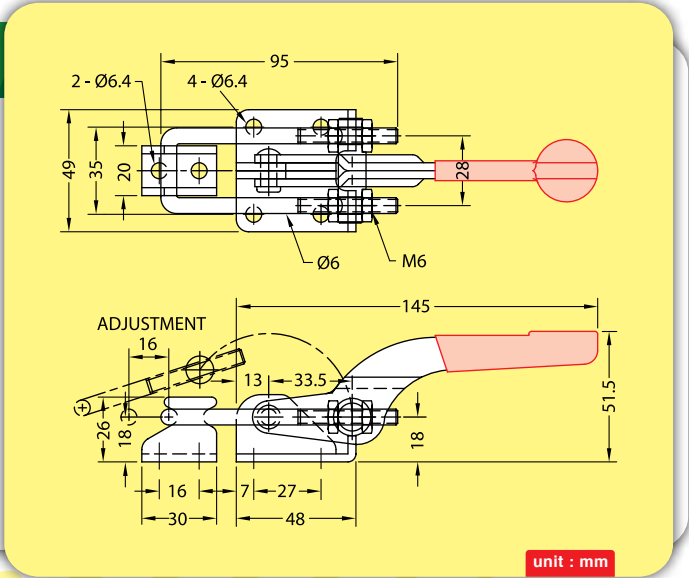

**Holding Capacity : 470kg MAX**

**Weight : 328g**

unit : mm

**Model : L132**

\*Also available in Stainless Steel  
**Model : L132SS**

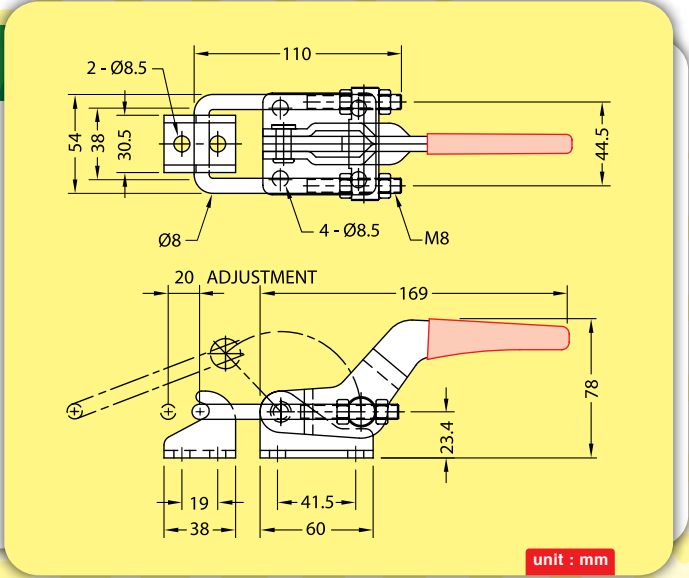

**Holding Capacity : 900kg MAX**

**Weight : 634g**

unit : mm

**Model : L133**

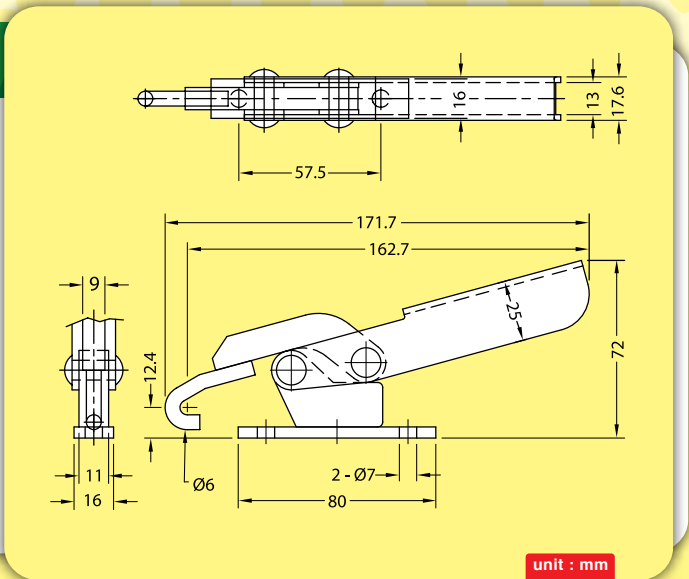

**Holding Capacity : 260kg MAX**

**Weight : 337g**

unit : mm



**LATCH TYPE**  
• TOGGLE CLAMP •

### Model : L134



**Holding Capacity : 180kg MAX**

**Weight : 372g**

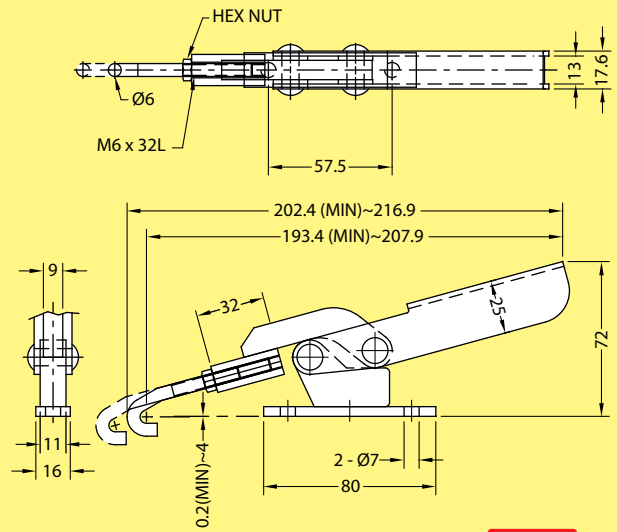

unit : mm

### Model : L352

\*Also available in Stainless Steel  
**Model : L352SS**



**Holding Capacity : 170kg MAX**

**Weight : 254g**

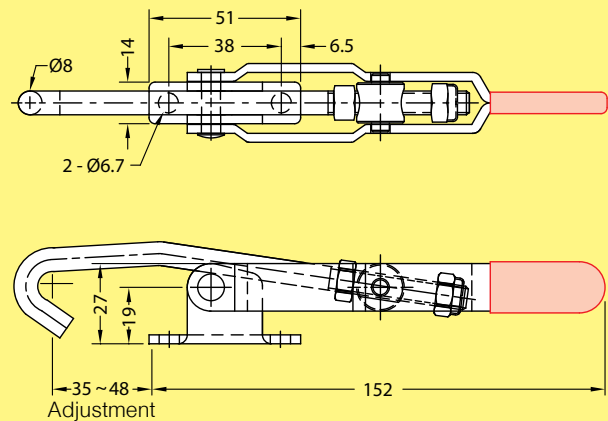

unit : mm

### Model : L354

\*Also available in Stainless Steel  
**Model : L354SS**



**Holding Capacity : 170kg MAX**

**Weight : 262g**

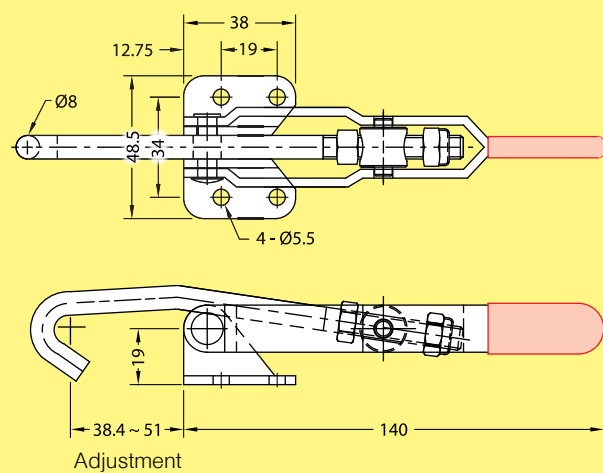

unit : mm

**LATCH TYPE**  
• TOGGLE CLAMP •



**Model : L138**

\*Also available in Stainless Steel  
**Model : L138SS**

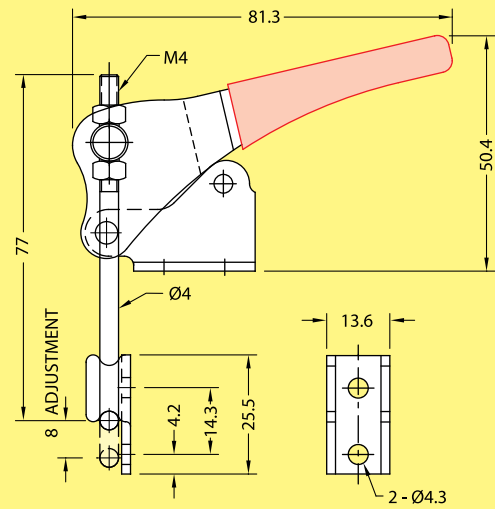
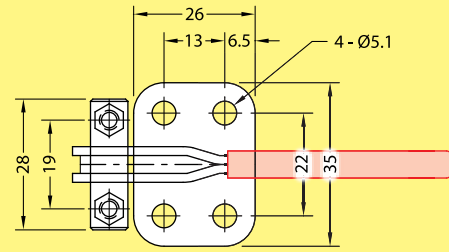

unit : mm

**Holding Capacity : 225kg MAX**

**Weight : 100g**

**Model : L148**

\*Also available in Stainless Steel  
**Model : L148SS**

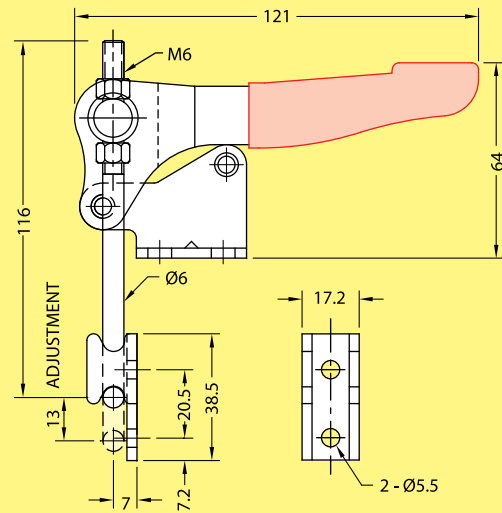
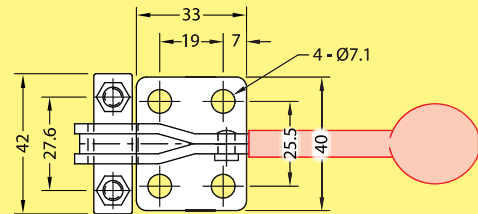

unit : mm

**Holding Capacity : 450kg MAX**

**Weight : 315g**



**LATCH TYPE**  
• TOGGLE CLAMP •

**Model : L158**

\*Also available in Stainless Steel  
**Model : L158SS**

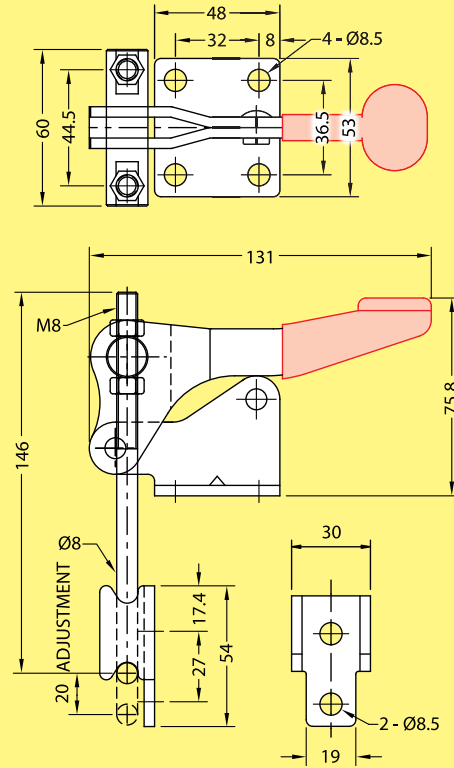

unit : mm

**Holding Capacity : 900kg MAX**

**Weight : 700g**

**Usage**



**Usage**



**Horizontal Handle**

**LATCH TYPE**  
• TOGGLE CLAMP •



**Model : L350**

\*Also available in Stainless Steel  
**Model : L350SS**

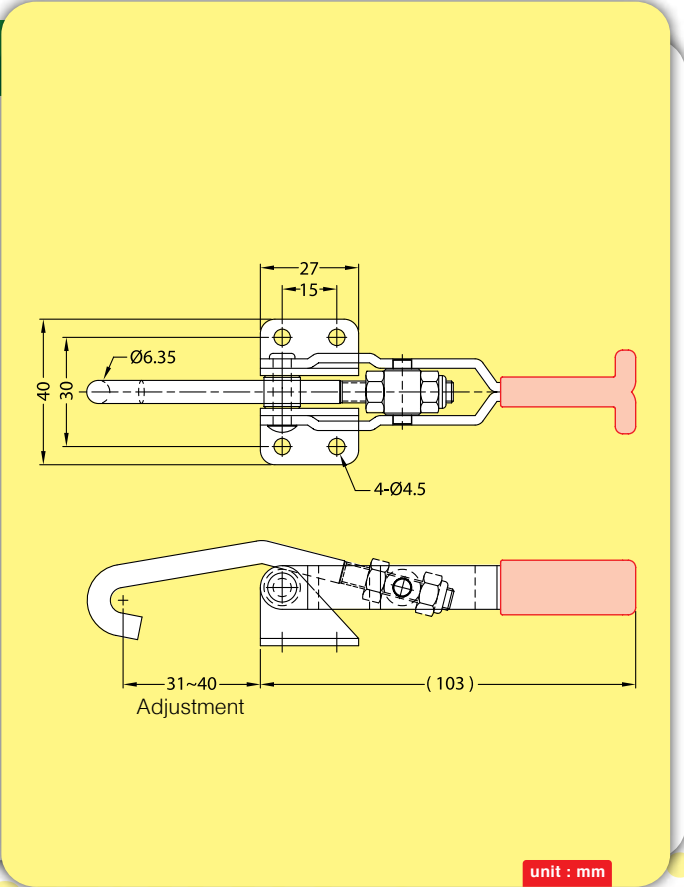

unit : mm

**Holding Capacity : 130kg MAX**

**Weight : 120g**

**Model : L356**

\*Also available in Stainless Steel  
**Model : L356SS**

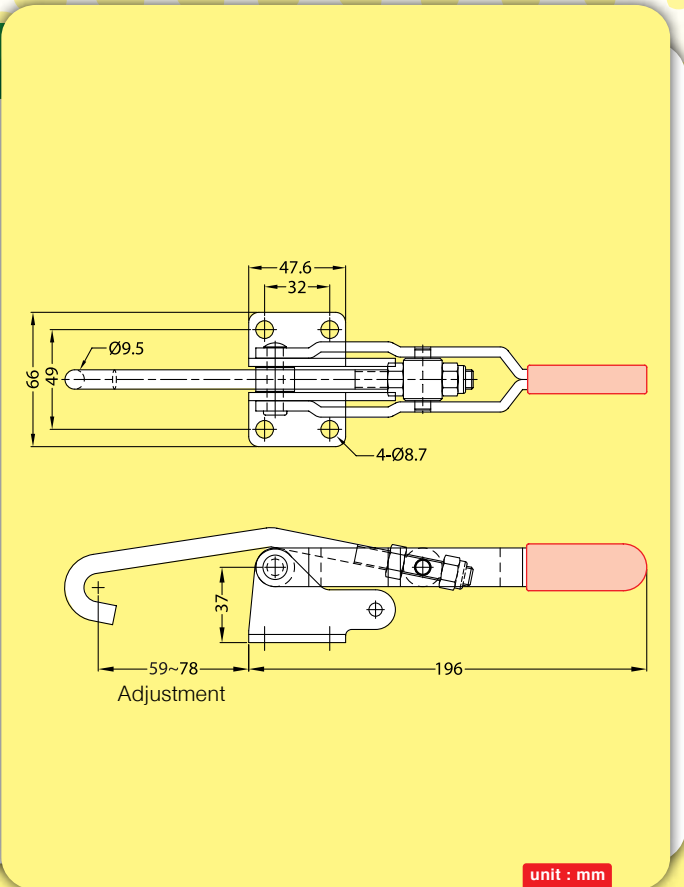

unit : mm

**Holding Capacity : 340kg MAX**

**Weight : 690g**



**Model : L135**



**Holding Capacity : 3400kg MAX**

**Weight : 1955g**

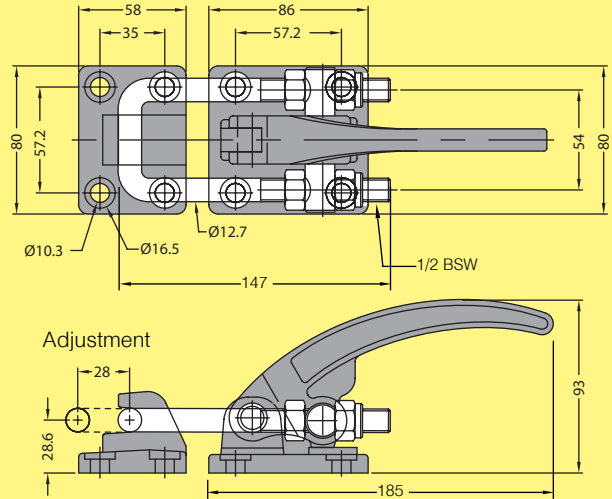

unit : mm

**Model : L360**

\*Also available in Stainless Steel  
**Model : L360SS**



**Holding Capacity : 1700kg MAX**

**Weight : 558g**

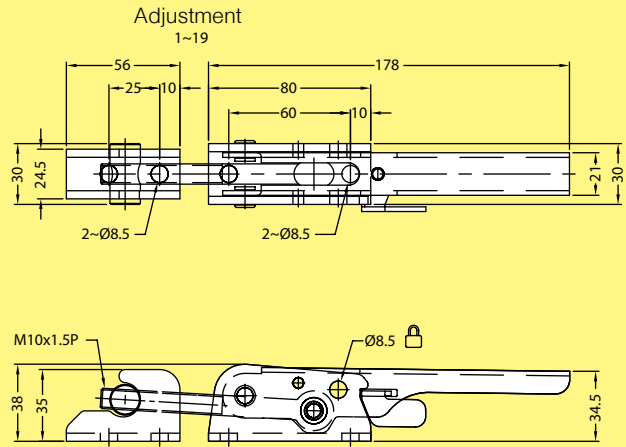

unit : mm

**Model : L365**

\*Also available in Stainless Steel  
**Model : L365SS**



**Holding Capacity : 900kg MAX**

**Weight : 258g**

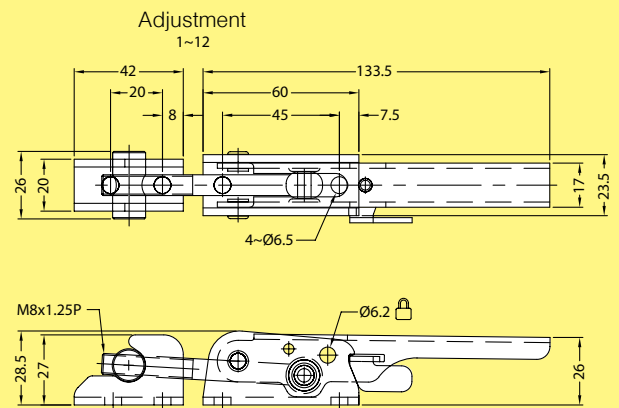

unit : mm



**LATCH TYPE**  
 • TOGGLE CLAMP •



**Model : L137**

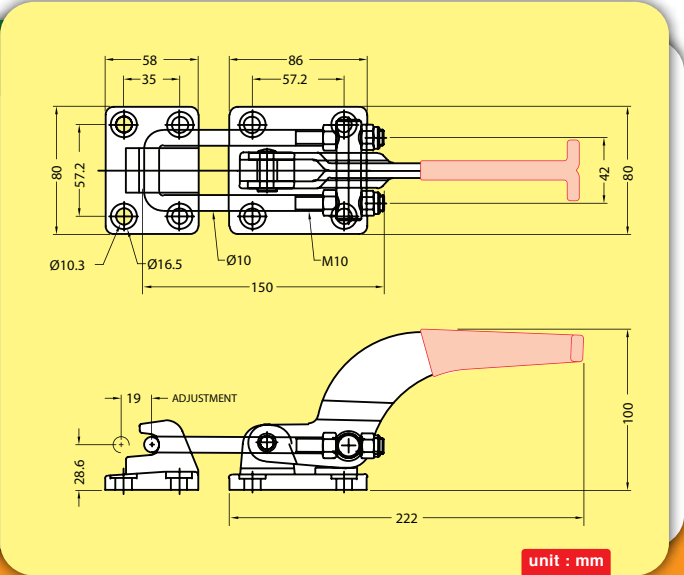

**Holding Capacity : 1800kg MAX**

**Weight : 1775g**





**LATCH TYPE**  
• TOGGLE CLAMP •

**Model : L370**

\*Also available in Stainless Steel  
**Model: L370SS**



**Holding Capacity : 470kg MAX**

**Weight : 298g**

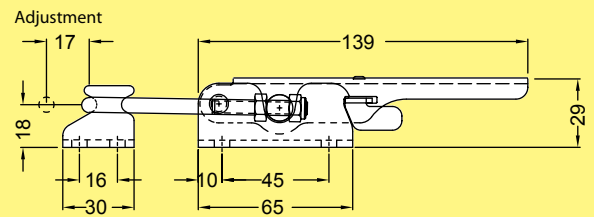
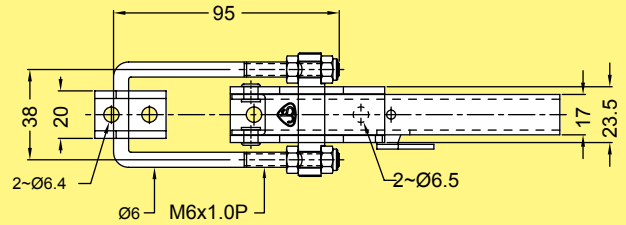

unit : mm

**Model : L375**

\*Also available in Stainless Steel  
**Model: L375SS**



**Holding Capacity : 900kg MAX**

**Weight : 682g**

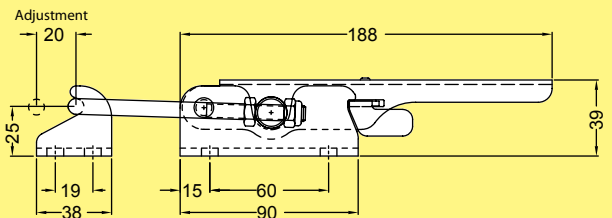
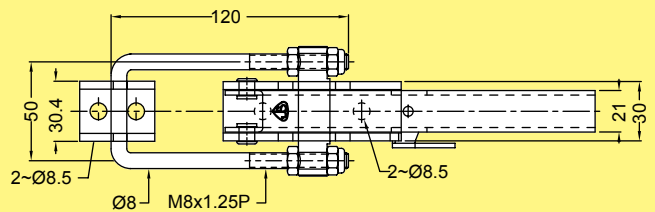

unit : mm

**Usage**



**Usage**



**HEAVY DUTY  
WELDABLE  
• TOGGLE CLAMP •**



**Model : AR801, AR802, AR803**

Model	Handle Moves	Bar Moves
AR801	116°	187°
AR802	120°	190°
AR803	120°	190°

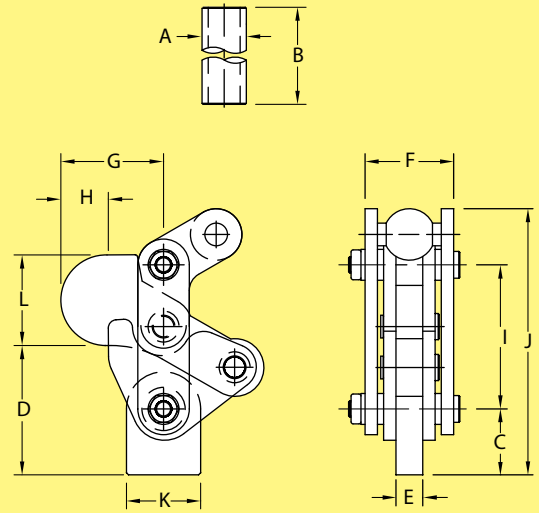
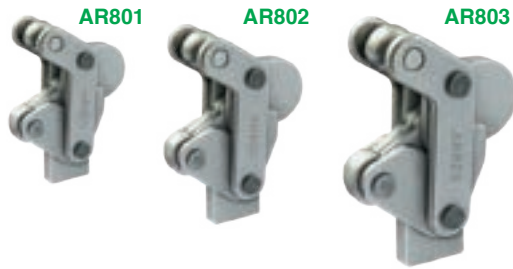

unit : mm

Model	Holding Capacity	A	B	C	D	E	F	G	H	I	J	K	L	Weight
AR801	200kg	Ø13.5	122	23.5	45	8	33	40	17	50	95	26	30	604g
AR802	500kg	Ø21.5	140	32	64	13	45	48	23	70	130	36	44	1455g
AR803	1000kg	Ø21.5	140	36	82	16	57	57	23	92	165	50	55	2820g

**Model : AR801SB**

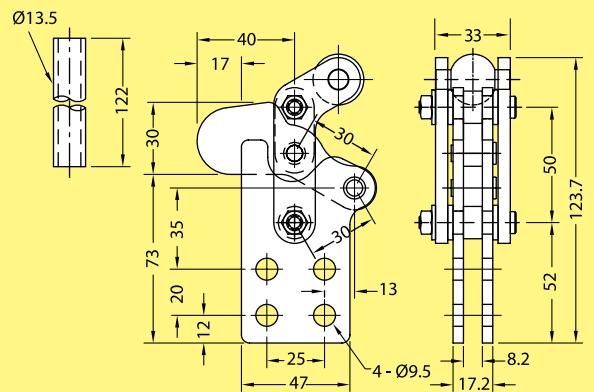
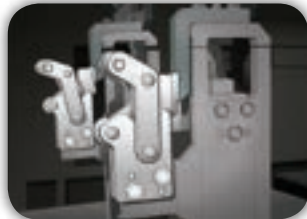

unit : mm

**Holding Capacity : 200kg MAX  
Weight : 683g**

**Handle Moves ... 116°  
Bar Moves ... 187°**

**Model : AR802SB**

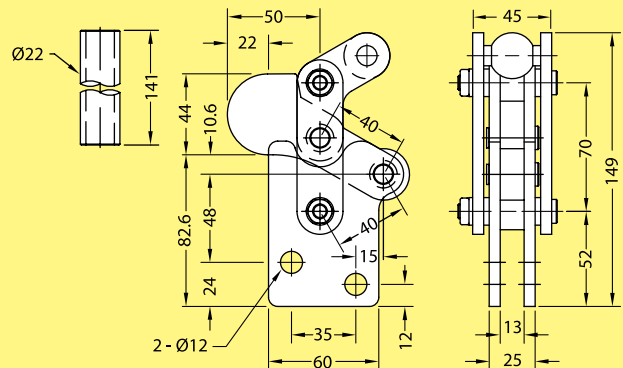

unit : mm

**Holding Capacity : 500kg MAX  
Weight : 1542g**

**Handle Moves ... 120°  
Bar Moves ... 190°**

**AIR POWER**  
• TOGGLE CLAMP •



**Model : V120RA**



**Holding Capacity : 91kg MAX**  
**Weight : 523g**

**Handle Moves ... 60°**  
**Bar Moves ... 100°**

**MAX AIR PRESSURE : 9.9kgf / cm<sup>2</sup>**

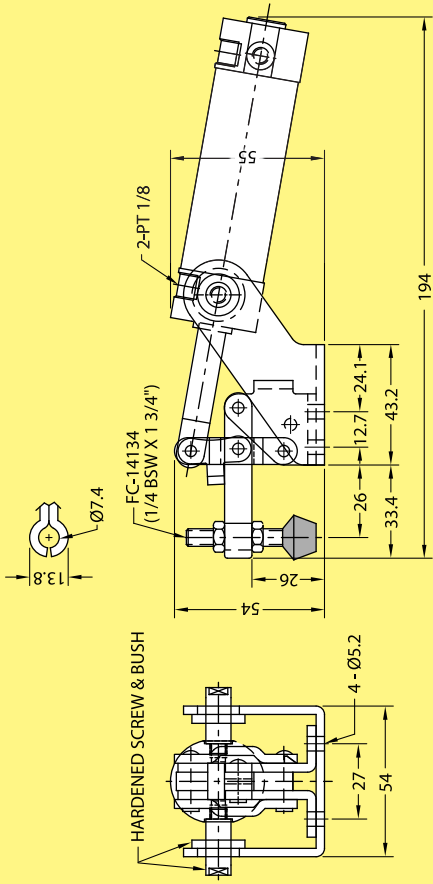

unit : mm

**Model : V130A**



**Holding Capacity : 227kg MAX**  
**Weight : 787g**

**Handle Moves ... 60°**  
**Bar Moves ... 100°**

**MAX AIR PRESSURE : 9.9kgf / cm<sup>2</sup>**

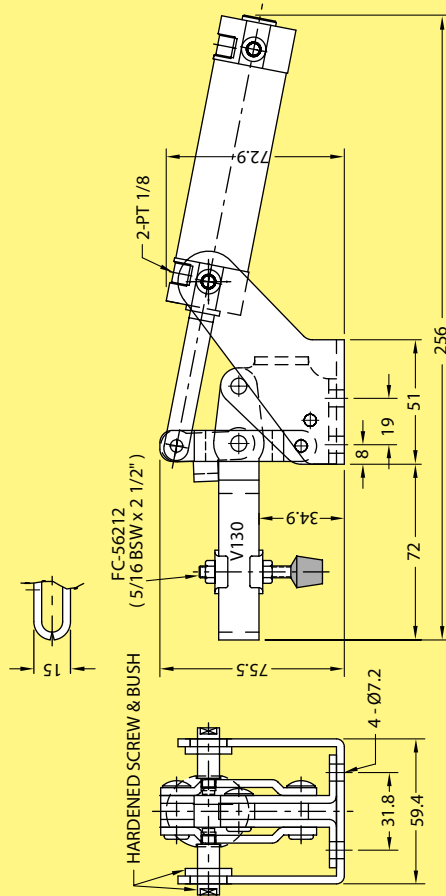

unit : mm

**AIR POWER TOGGLE CLAMP**

**Model : V370SA**



**NEW PRODUCT**



**Holding Capacity : 1000kg MAX**  
**Weight : 6.4 kg**

**Handle Moves : 75°**  
**Bar Moves : 110°**

**MAX AIR PRESSURE : 9.9kgf / cm<sup>2</sup>**

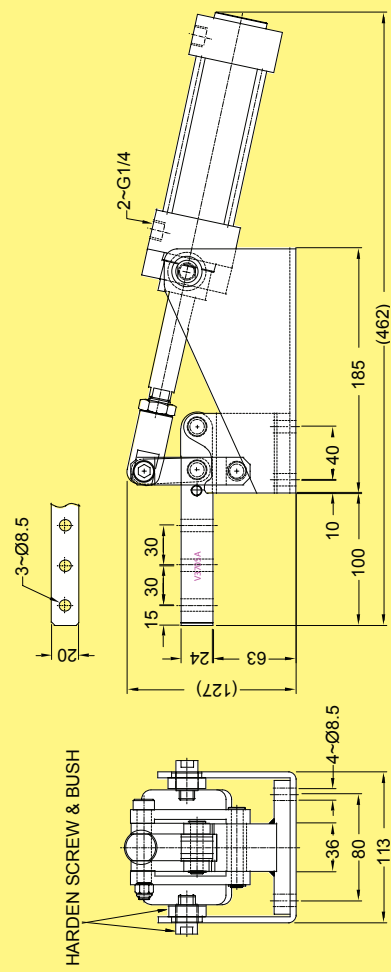

unit : mm

**Model : H360SA**



**NEW PRODUCT**



**Holding Capacity : 1000kg MAX**  
**Weight : 6.4kg**

**Handle Moves : 65°**  
**Bar Moves : 110°**

**MAX AIR PRESSURE : 9.9kgf / cm<sup>2</sup>**

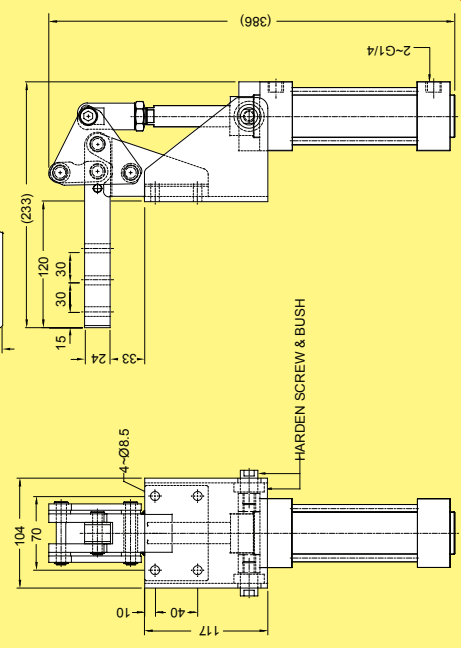

unit : mm

**AIR POWER**  
• TOGGLE CLAMP •



**Model : V210A**



**Holding Capacity : 340kg MAX**  
**Weight : 1765g**

**Handle Moves ... 58°**  
**Bar Moves ... 105°**

**MAX AIR PRESSURE : 9.9kgf / cm<sup>2</sup>**

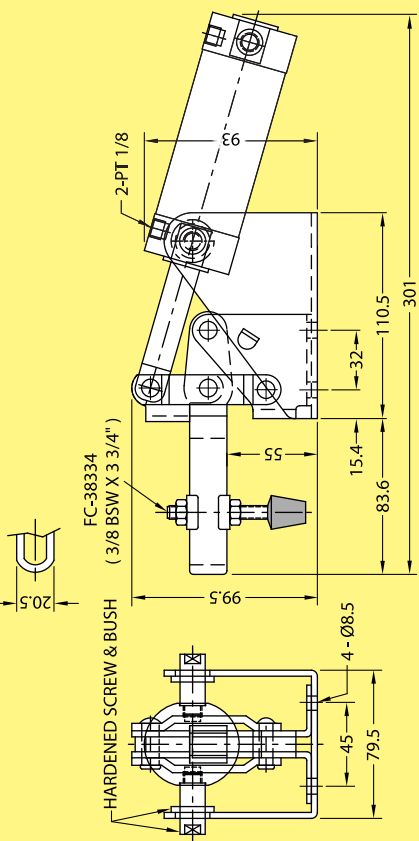

unit : mm

**Model : V247UA**



**Holding Capacity : 450kg MAX**  
**Weight : 3280g**

**Handle Moves ... 58°**  
**Bar Moves ... 100°**

**MAX AIR PRESSURE : 9.9kgf / cm<sup>2</sup>**

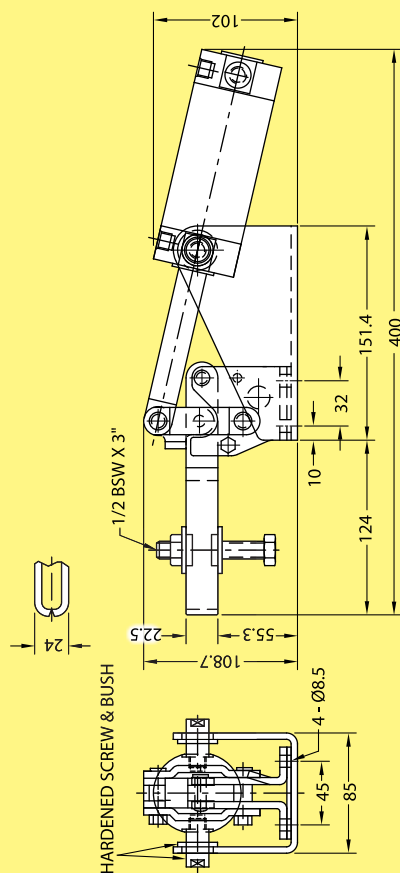

unit : mm

**AIR POWER**  
• TOGGLE CLAMP •

**Model : P330A**



**Holding Capacity : 952kg MAX**  
**Weight : 2312g**

**Handle Moves ... 90°**  
**Travel ... 32mm**

**MAX AIR PRESSURE : 9.9kgf / cm<sup>2</sup>**

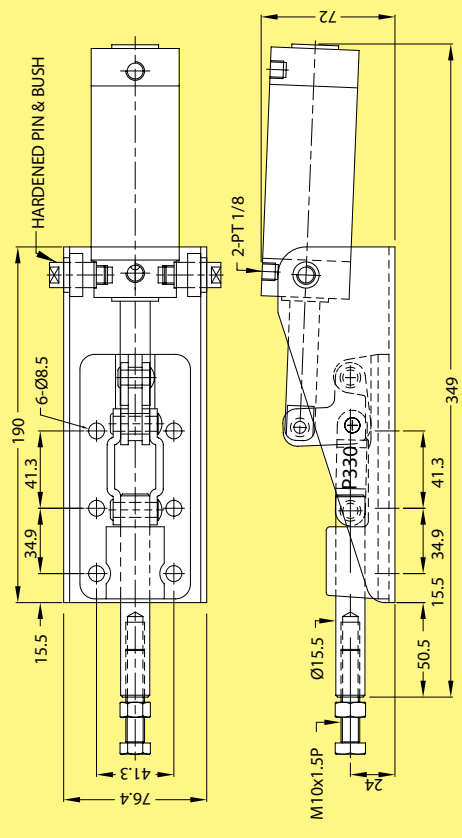

unit : mm

**Usage**



**Usage**

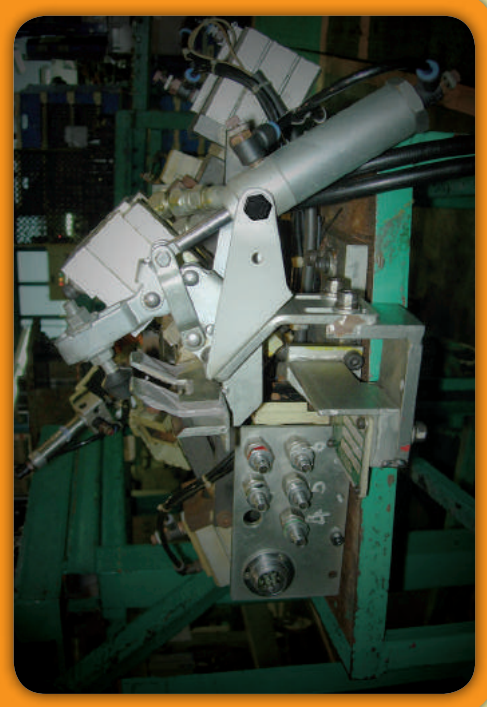

**AIR POWER**  
• TOGGLE CLAMP •

**Model : H228FA**

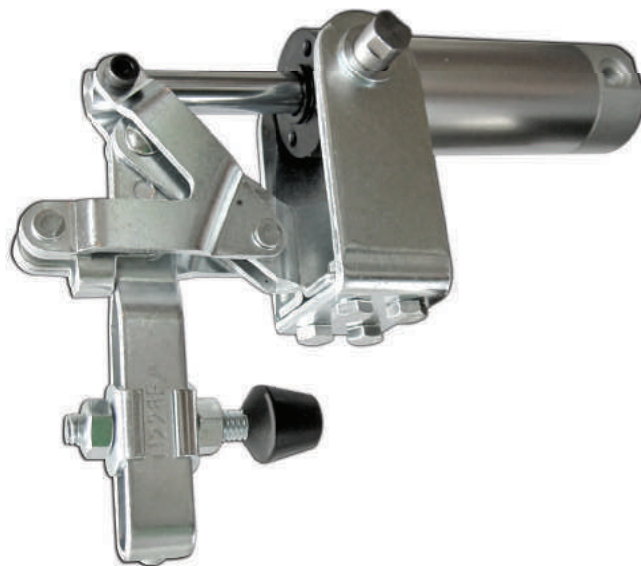

**Holding Capacity : 100kg MAX**  
**Weight : 930g**

**Handle Moves ... 51°**  
**Arm Moves ... 90°**

**MAX AIR PRESSURE : 9.9kgf / cm<sup>2</sup>**

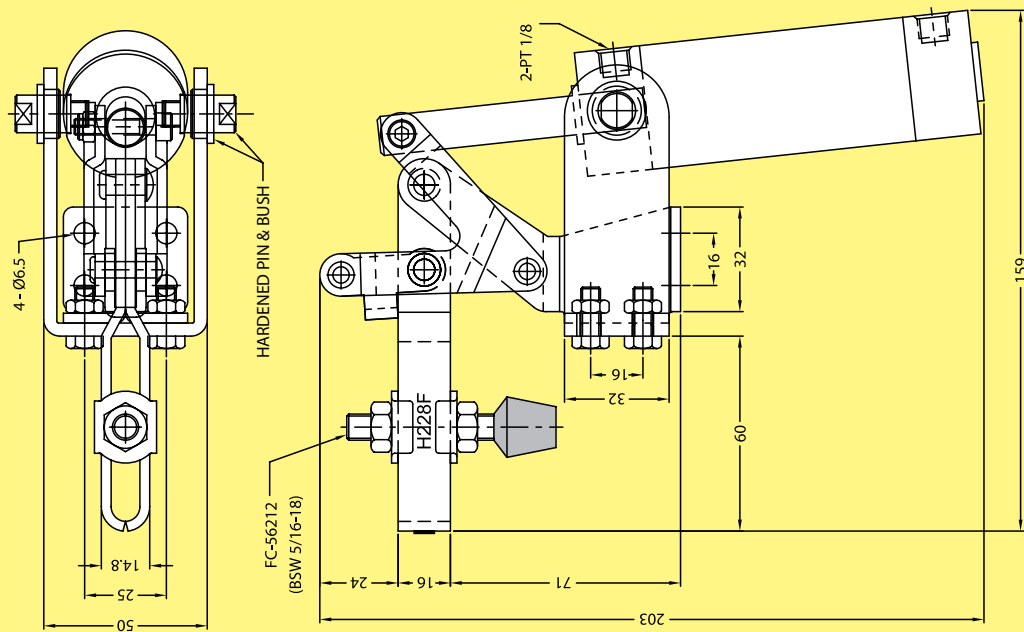

unit : mm



**POWER SCREEN  
TENSIONER &  
ACCESSORIES**  
• TOGGLE CLAMP •

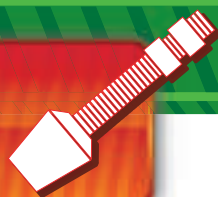

**Power Screen Tensioner**

**Model : PST4050**



<b>Screen Pinching Width</b>	300mm
<b>Air Pressure Supply</b>	4 to 9kg / cm <sup>2</sup>
<b>Cylinder Bore</b>	40mm
<b>Tension Stroke</b>	50mm
<b>Dimension ( mm )</b>	300(W) x 475(L) x 280(H)
<b>Weight</b>	3.9kg

**Rubber Cushion Spindle**

( Complete with 2 Hexagon Nuts )

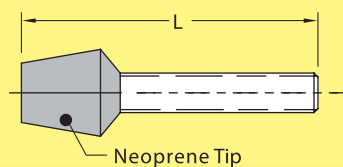

unit : mm

Part No.	Size	L	Weight
FC-042707	M4 x 0.7	27mm	4g
FC-044007	M4 x 0.7	40 mm	6g
FC-053508	M5 x 0.8	35 mm	8.5g
FC-084312	M8 x 1.25	43 mm	28.2g
FC-12400	BSW 1/2 - 12	4"	148g
FC-14134	BSW 1/4 - 20	1 3/4"	18.2g
FC-14200	BSW 1/4 - 20	2"	19.2g
FC-38334	BSW 3/8 - 16	3 3/4"	65g
FC-38412	BSW 3/8 - 16	4 1/2"	73g
FC-56212	BSW 5/16 - 18	2 1/2"	35g
FC-56300	BSW 5/16 - 18	3"	35.8g

**Flanged Washer**

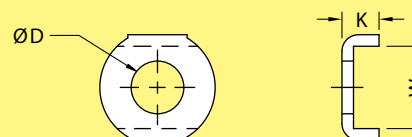

unit : mm

Part No.	ØD x K x W	To Suit Toggle Clamp	W
FW-043084	4.3 x 3.7 x 8.4	H225	1.2g
FW-051090	5.1 x 3.5 x 9	V105, H301, V150, V209, V209B, H430, H430B, H209, H209B	1.7g
FW-064100	6.4 x 4.7 x 10	H313	1.9g
FW-064120	6.4 x 4 x 12	V108, V108F, H235, H235B, H238, H440, H440B	2.2g
FW-064138	6.4 x 4 x 13.8	V120, V120B	2.4g
FW-065150	6.5 x 6.5 x 15	H380, H380B, V141, V141B, V125	6.4g
FW-085150	8.5 x 6.5 x 15	V101, V110L, V110L1, V130, V130B, V130L, V130BL, V142, V142B, V160, H230, H230L, H230F, H230FL, H245, H245B, H450, H450B, H228F, H228FA, V130A	5.8g
FW-085207	8.5 x 6.5 x 20.7	H381, H381B, H381H	10g
FW-105215	10.5 x 7.5 x 21.5	V210, V210B, V170, H300, H300L, H300H, H300HL, H330, H460, H460B, H330L, H381H, H384, H384B, H520L, H550L, V210A	10g
FW-130245	13 x 7.5 x 24.5	V247U, V247UB, V310, V247UA	19.5g



## Swivel Foot Spindle

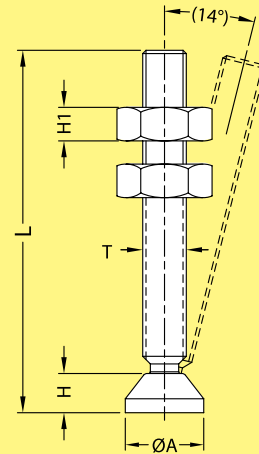

unit : mm

Part No.	L	ØA	H	H1	T	Weight
SF-M0606510RB12	65	12	6.2	5	M6 x 1.0P	19g
SF-M0807512RB15	75	15	7.5	6.2	M8 x 1.25P	37g
SF-M1009515RB18	95	18	9.0	7.7	M10 x 1.5P	74g
SF-M1210017RB20	100	20	10.5	9.8	M12 x 1.75P	109g
SF-M1612020RB28	120	28	13.0	12.2	M16 x 2.0P	238g

Part No.	L	ØA	H	H1	T	Weight
SF-B140212RB12	63	12	6.2	5	1/4 BSW	21g
SF-B516300RB15	76	15	7.5	6.2	5/16 BSW	36g
SF-B380334RB18	95	18	9.0	7.7	3/8 BSW	62g
SF-B120400RB20	100	20	10.5	11	1/2 BSW	126g
SF-B580434RB28	120	28	13.0	13.6	5/8 BSW	235g

## Usage

• Swivel Foot Spindle •

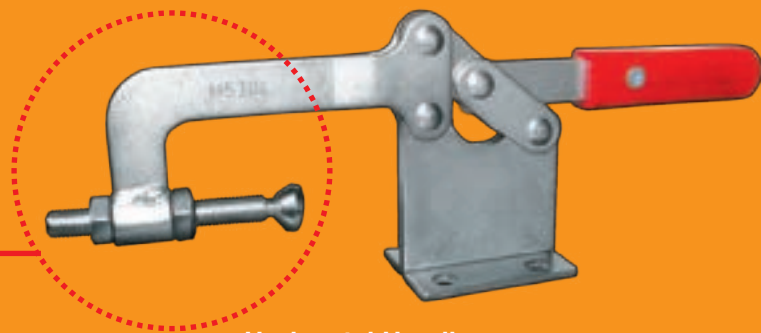
**Horizontal Handle**  
 – Toggle Clamp –

**SQUEEZE ACTION**  
• TOGGLE CLAMP •



**Model : SC2050**



**Holding Capacity : 150kg MAX**  
**Weight : 238g**

**Jaw Opening : 0 - 49 mm**

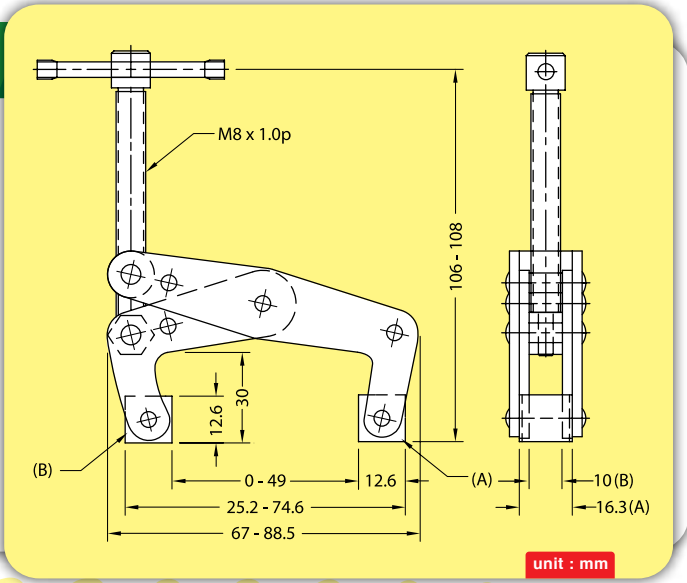

unit : mm

**Model : SC3075**



**Holding Capacity : 300kg MAX**  
**Weight : 660g**

**Jaw Opening : 0 - 79 mm**

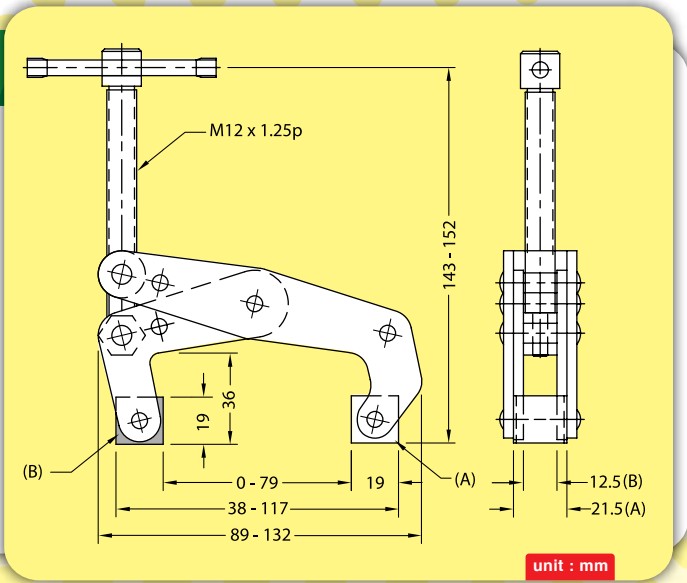

unit : mm

**Usage**



**Usage**





## Horizontal Lifting Clamp

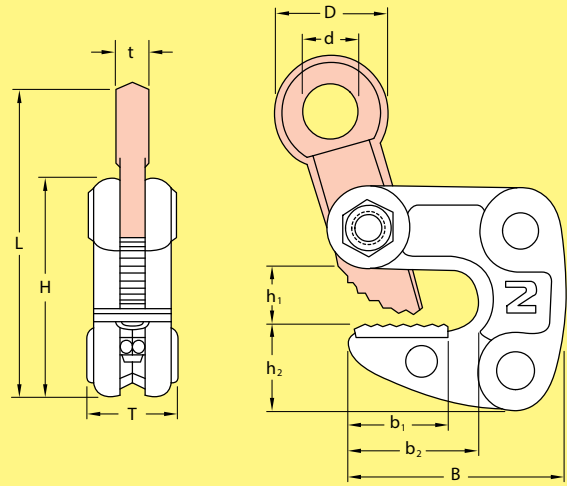

unit : mm

Model	Capacity (tons)	Clamping range (mm)	L	t	T	H	h1	h2	B	b1	b2	D	d	Weight (kg)
1. HLC-1	1	1 ~ 13	173	14	32	104	23.5	39.5	105	66	44	72	46	1.6
2. HLC-2	2	3 ~ 22	233	18	42	130	36	50	137	87	58	96	61	3.9
3. HLC-3	3	12 ~ 35	261	23	52	177	42	67.5	173.5	107	68	80	35	9

## Vertical Lifting Clamp (E-type)

\* Auto Lock / without Special Lock

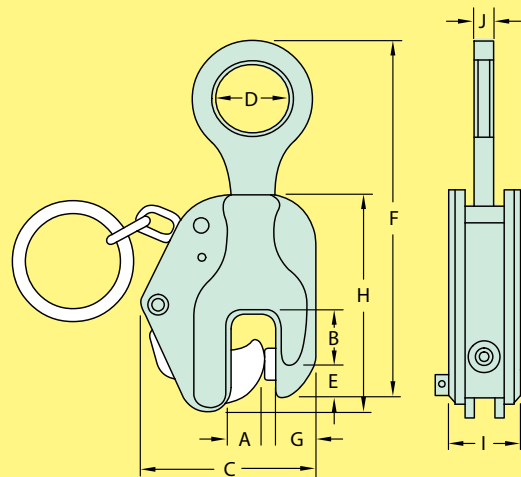

unit : mm

Model	Lifting Cap (tons)	Clamping range (mm)	Jay Opening (mm)	A	B	C	D	E	F	G	H	I	J	Weight (kg)
1. E-0001	1	2	0 - 22	24	36	125	50	24	220-260	30	156	52	14	3.6
2. E-0002	2	4	0 - 30	35	45	155	60	30	250-295	38	190	60	18	6.0
3. E-0003	3	6	0 - 35	40	50	175	60	35	296-360	40	226	68	20	9.2
4. E-0005	5	10	0 - 50	50	58	218	65	45	350-420	60	270	76	22	16.5

### Applications

- At building construction field
- At subway construction (civil engineering construction) sites

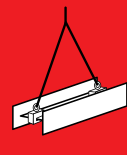
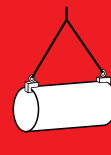
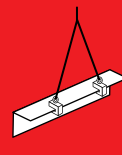
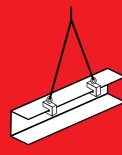
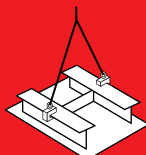
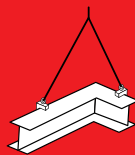

**MOULD CLAMP**  
• TOGGLE CLAMP •



**Mould Clamp : Heel Type**



**Heel Type**

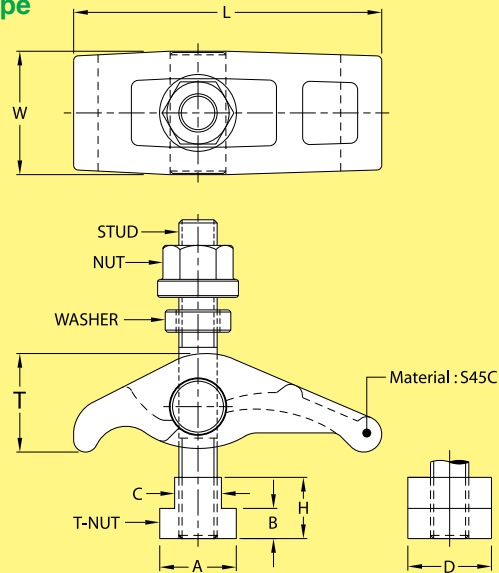

\*Custom Size To Meet Your Requirement unit : mm

Model No.	T	W	L	*A	*B	*C	*D	*H	STUD	WEIGHT
MCH01	43	54	130	28	10	18	30	20	M16 x 150L	1.5kg
MCH02	52	60	152	36	14	22	40	25	M20 x 150L	2.3kg
MCH03	43	54	130	28	10	18	30	20	5/8" x 150L	1.5kg
MCH04	52	60	152	36	14	22	40	25	3/4" x 150L	2.3kg

**Mould Clamp : Step Type**



**Step Type**

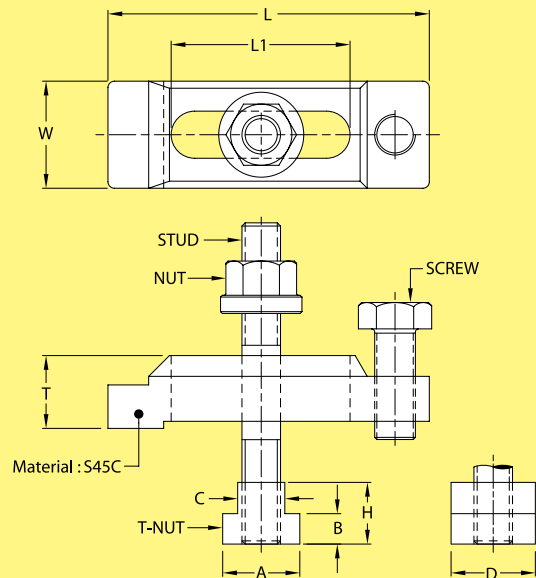

\*Custom Size To Meet Your Requirement unit : mm

Model No.	T	W	L	L1	*A	*B	*C	*D	*H	STUD	SCREW	WEIGHT
MCS01	30	43	130	70	28	10	18	30	20	M16 x 150L	M16 x 40L	1.2kg
MCS02	34	50	150	83	36	14	22	40	25	M20 x 150L	M20 x 50L	1.9kg
MCS03	30	43	130	70	28	10	18	30	20	5/8" x 150L	5/8" x 40L	1.2kg
MCS04	34	50	150	83	36	14	22	40	25	3/4" x 150L	3/4" x 50L	1.9kg



**TOGGLE  
LINK CLAMP**  
• LATCH •

**Model : TL01**

\*Also available in Stainless Steel  
**Model : TL01SS**



**Safe Load : 40kg MAX**

**Weight : 31g**

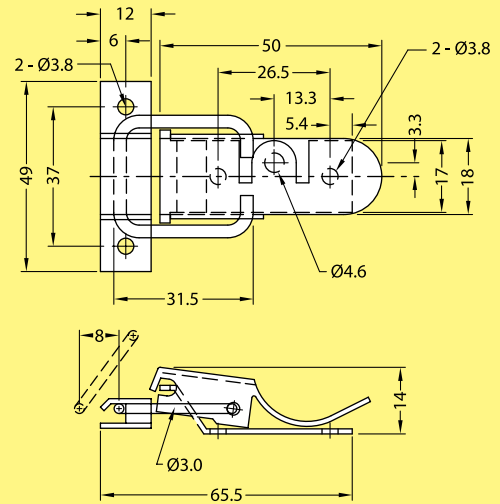

unit : mm

**Model : TL02**

\*Also available in Stainless Steel  
**Model : TL02SS**



**Weight : 73g**

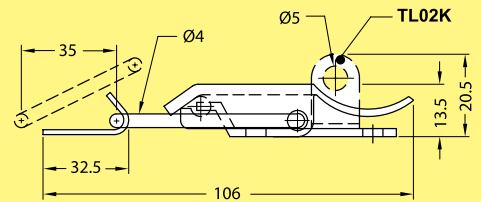
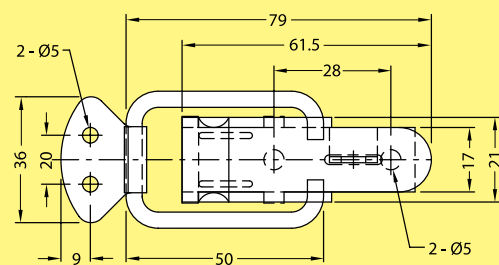

unit : mm

**Model : TL02K**

\*Also available in Stainless Steel  
**Model : TL02KSS**



**Safe Load : 150kg MAX**

**Weight : 76g**

**Model : TL03**

\*Also available in Stainless Steel  
**Model : TL03SS**



**Weight : 21g**

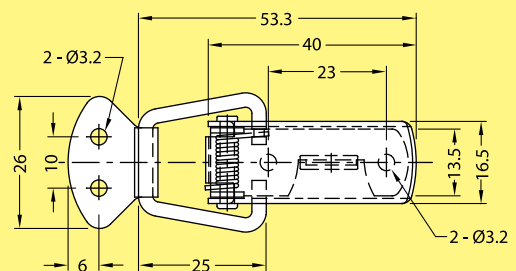

**Model : TL03K**

\*Also available in Stainless Steel  
**Model : TL03KSS**



**Safe Load : 110kg MAX**

**Weight : 21g**

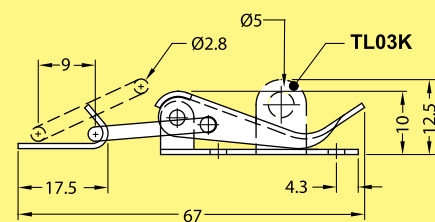

unit : mm

**TOGGLE  
LINK CLAMP**  
• LATCH •



**Model : TL04**

\*Also available in Stainless Steel  
**Model : TL04SS**



**Weight : 41g**

**Model : TL04K**

\*Also available in Stainless Steel  
**Model : TL04KSS**



**Safe Load : 170kg MAX**

**Weight : 41g**

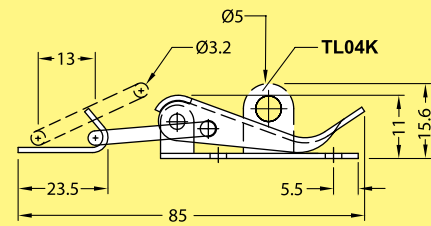
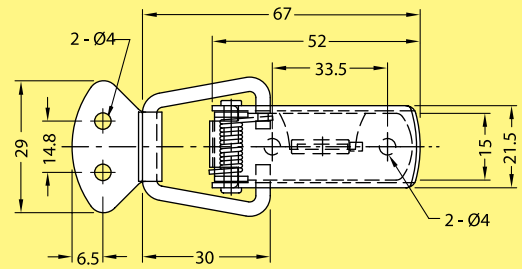

unit : mm

**Model : TL05**

\*Also available in Stainless Steel  
**Model : TL05SS**



**Safe Load : 230kg MAX**

**Weight : 95g**

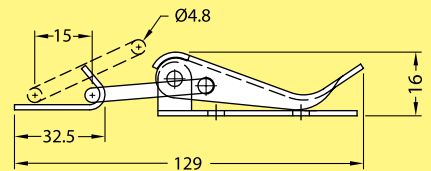
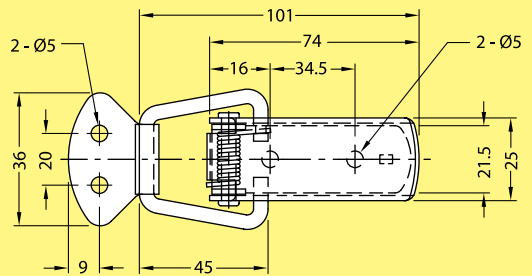

unit : mm

**Model : TL06K**



**Safe Load : 300kg MAX**

**Weight : 200g**

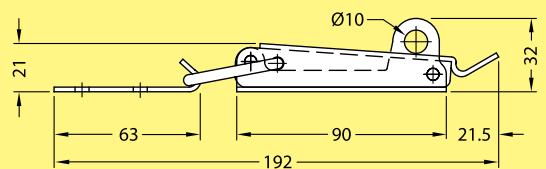
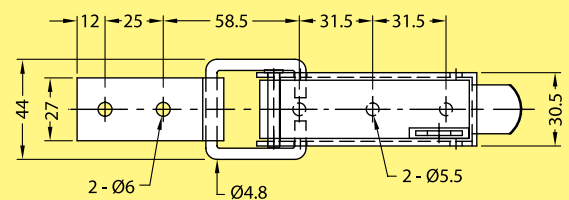

unit : mm



**TOGGLE  
LINK CLAMP**  
• LATCH •

**Model : TL116**

\*Also available in Stainless Steel  
**Model : TL116SS**



**Safe Load : 50kg MAX**

**Weight : 43g**

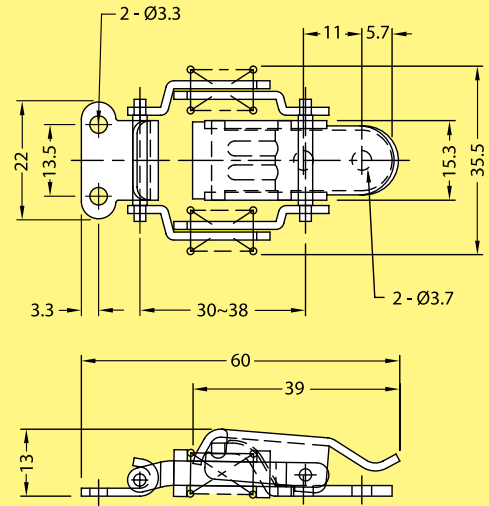

unit : mm

**Model : TL124**

\*Also available in Stainless Steel  
**Model : TL124SS**



**Weight : 78g**

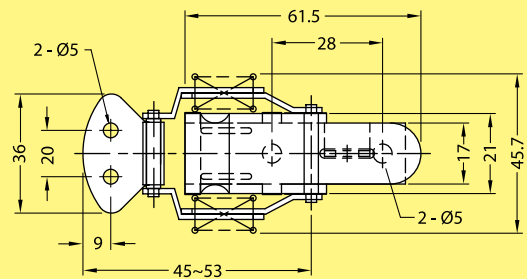

unit : mm

**Model : TL124K**

\*Also available in Stainless Steel  
**Model : TL124KSS**



**Safe Load : 80kg MAX**

**Weight : 81g**

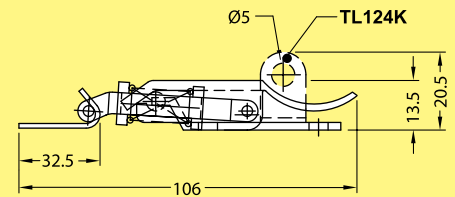

unit : mm

**Model : TL118**

\*Also available in Stainless Steel  
**Model : TL118SS**



**Safe Load : 50kg MAX**

**Weight : 27g**

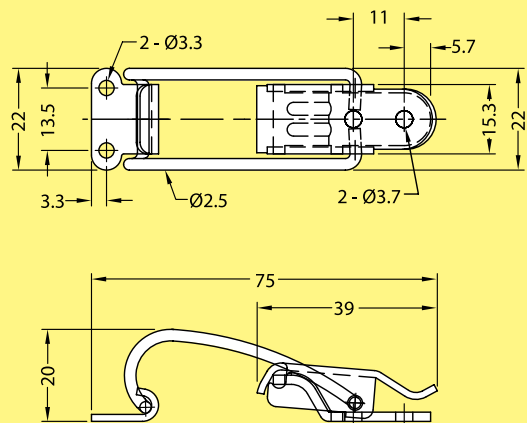

unit : mm



**TOGGLE  
LINK CLAMP**  
• LATCH •



**Model : TL119**



Safe Load : 15kg MAX

Weight : 8g

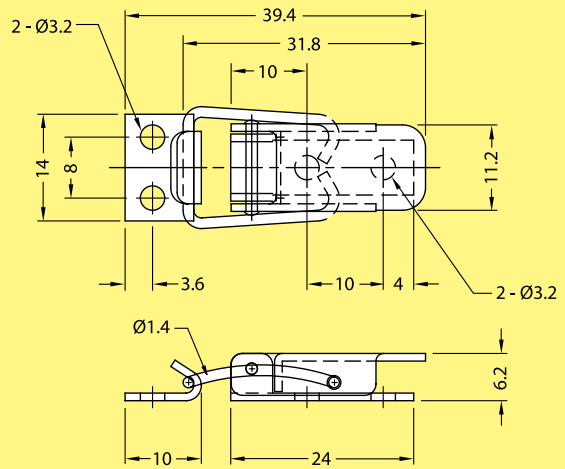

unit : mm

**Model : TL121**



Safe Load : 15kg MAX

Weight : 6g

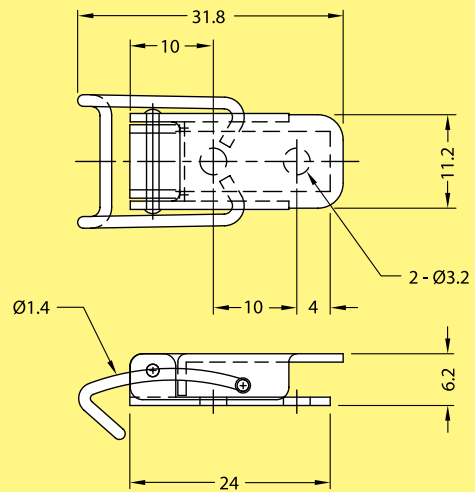

unit : mm

**Model : TL135**

\*Also available in Stainless Steel  
**Model : TL135SS**



Safe Load : 100kg MAX

Weight : 77g

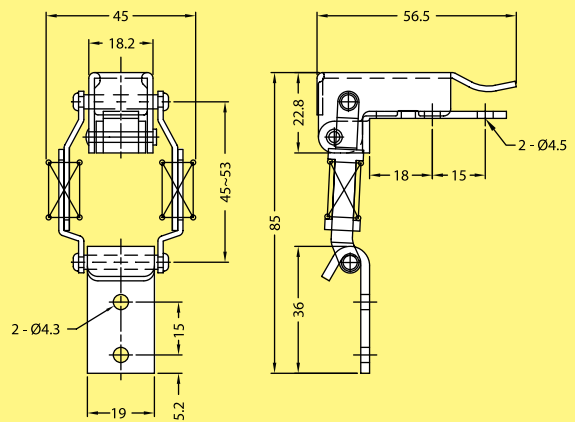

unit : mm



**TOGGLE  
LINK CLAMP**  
• LATCH •

**Model : TL104**

\*Also available in Stainless Steel  
**Model : TL104SS**



**Weight : 23g**

**Model : TL104K**

\*Also available in Stainless Steel  
**Model : TL104KSS**



**Safe Load : 55kg MAX**

**Weight : 22g**

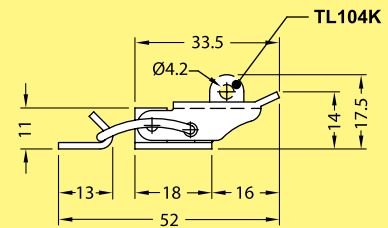
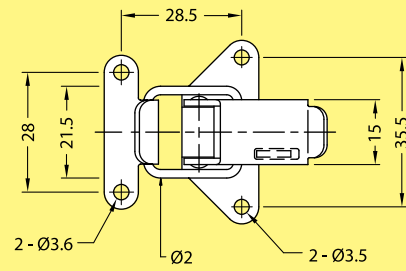

unit : mm

**Model : TL122**

\*Also available in Stainless Steel  
**Model : TL122SS**



**Safe Load : 100kg MAX**

**Weight : 92g**

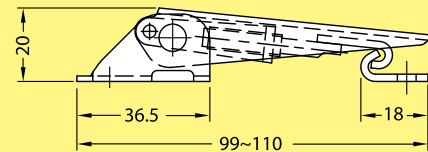
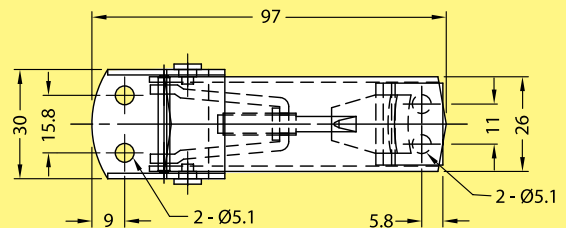

unit : mm

**Model : TL107**



**Safe Load : 100kg MAX**

**Weight : 63g**

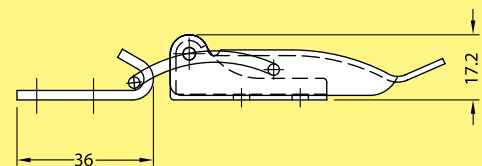
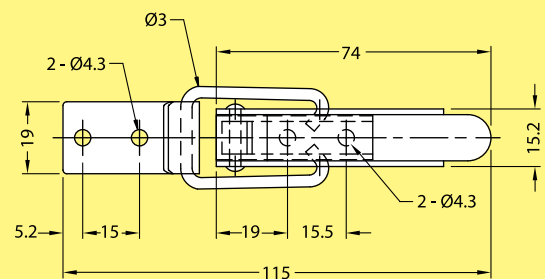

unit : mm

**TOGGLE  
LINK CLAMP**  
• LATCH •



**Model : TL127K**

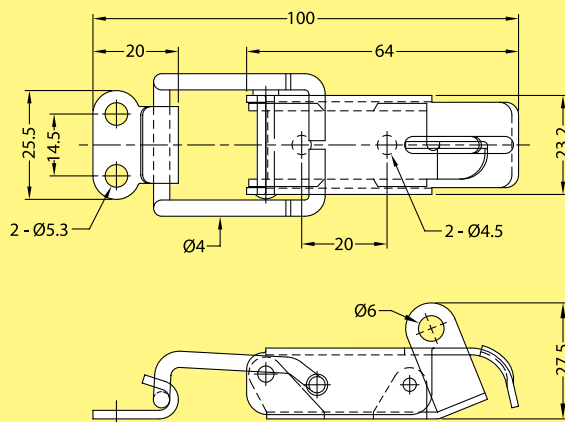

unit : mm

Safe Load : 180kg MAX

Weight : 74g

**Model : TL129**

\*Also available in Stainless Steel  
**Model : TL129SS**

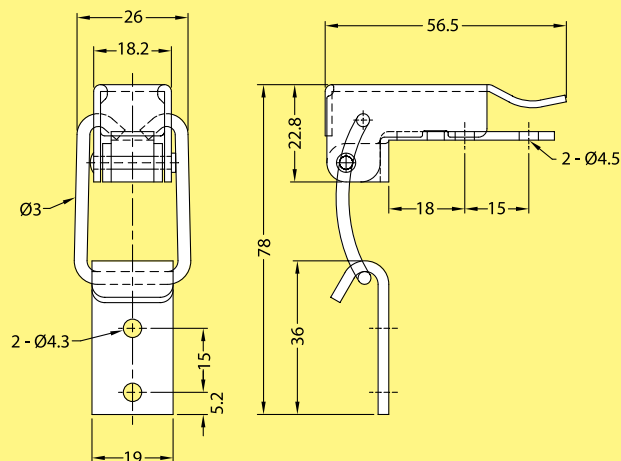

unit : mm

Safe Load : 100kg MAX

Weight : 64g

**Model : TL305**

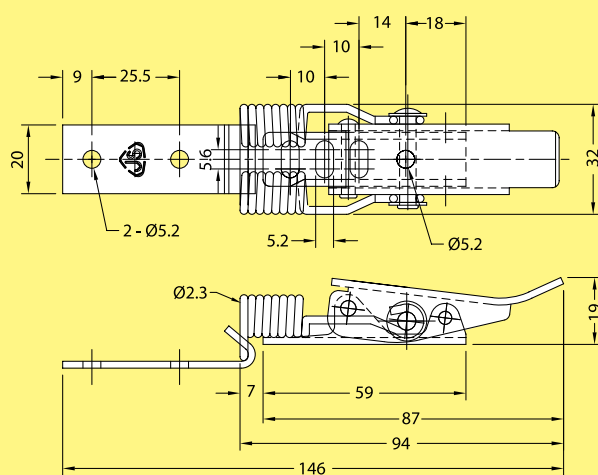

unit : mm

Safe Load : 100kg MAX

Weight : 104g



**TOGGLE  
LINK CLAMP**  
• LATCH •

**Model : TL105**

\*Also available in Stainless Steel  
**Model : TL105SS**

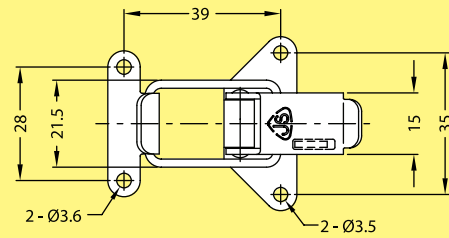

**Model : TL105K**

\*Also available in Stainless Steel  
**Model : TL105KSS**

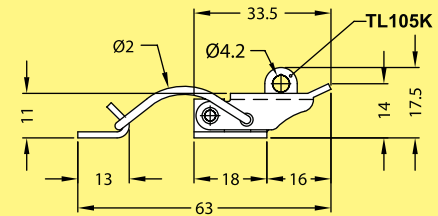

**Safe Load : 50kg MAX**

**Weight : 22.5g, 23g**

unit : mm

**Model : TL112**

\*Also available in Stainless Steel  
**Model : TL112SS**

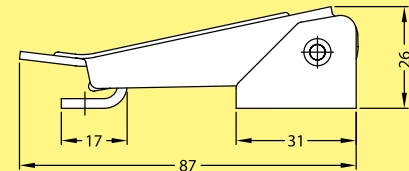
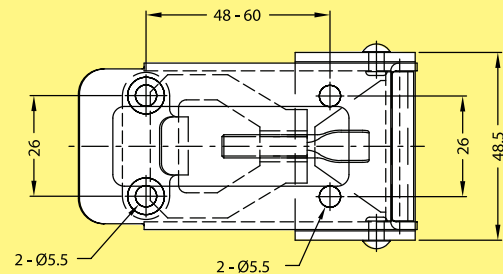

**Safe Load : 200kg MAX**

**Weight : 171g**

unit : mm

**Model : TL123**

\*Also available in Stainless Steel  
**Model : TL123SS**

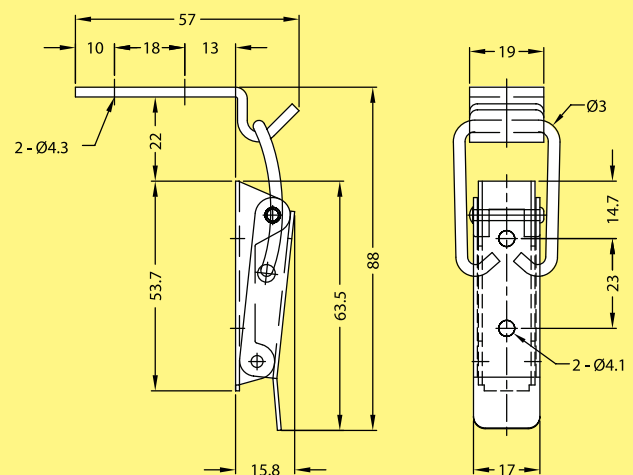

**Safe Load : 100kg MAX**

**Weight : 55g**

unit : mm

**TOGGLE  
LINK CLAMP**  
• LATCH •



**Model : TL307**

\*Also available in Stainless Steel  
**Model : TL307SS**



**Safe Load : 40kg MAX**

**Weight : 61g**

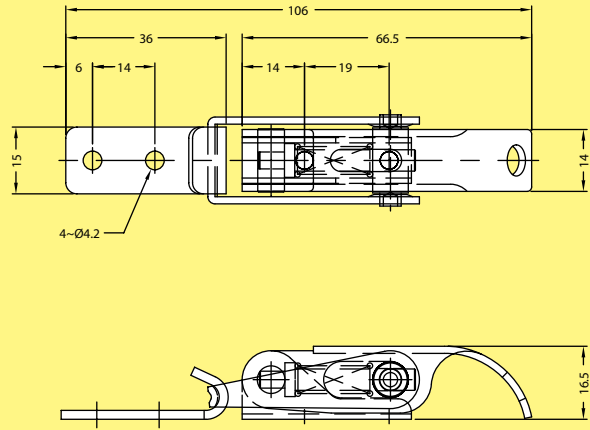

unit : mm

**Model : TL204**

\*Also available in Stainless Steel  
**Model : TL204SS**



**Safe Load : 60kg MAX**

**Weight : 38g**

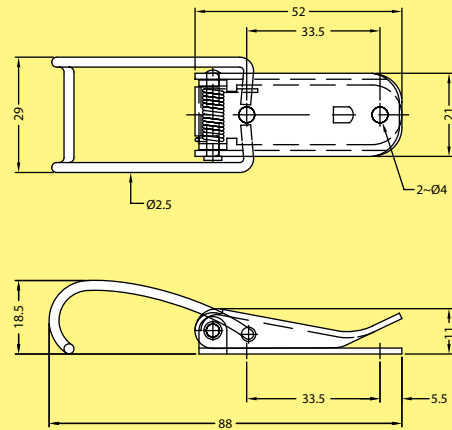

unit : mm

**Model : TL304**

\*Also available in Stainless Steel  
**Model : TL304SS**



**Model : TL304K**

\*Also available in Stainless Steel  
**Model : TL304KSS**



**Safe Load : 50kg MAX**

**Weight : 45g**

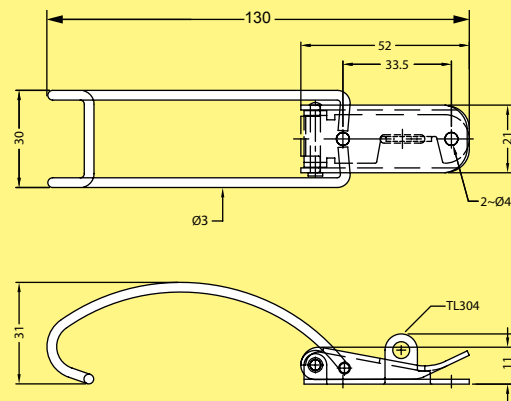

unit : mm



**Model : TL126**

\*Also available in Stainless Steel  
**Model : TL126SS**

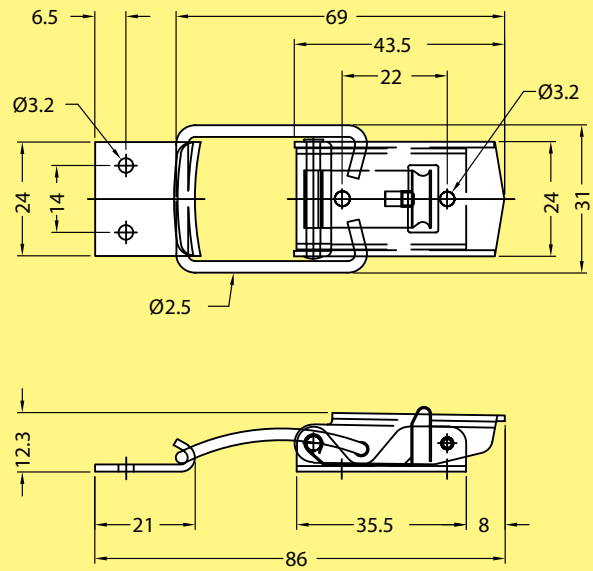

unit : mm

Safe Load : 60kg MAX

Weight : 37g



# UNIVERSAL RACK CLAMP



## Model : URC 6020

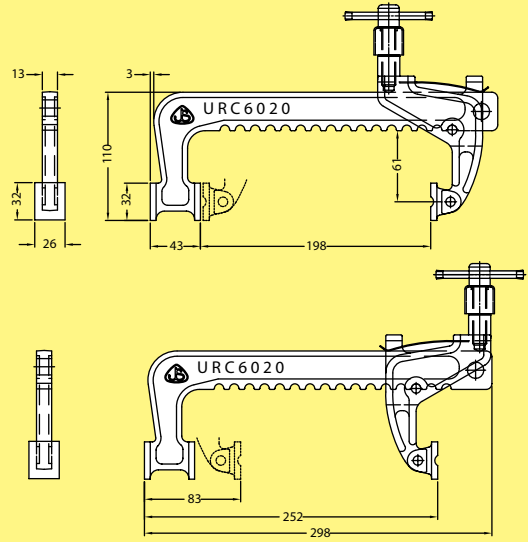

unit : mm

**Holding Capacity : 400kg MAX**  
**Weight : 1530g**

## Model : URC 6030

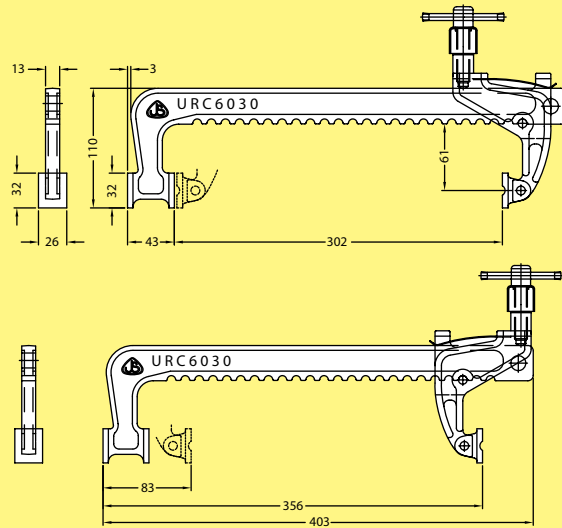

unit : mm

**Holding Capacity : 400kg MAX**  
**Weight : 1765g**





**C-CLAMP**

**C - CLAMP**

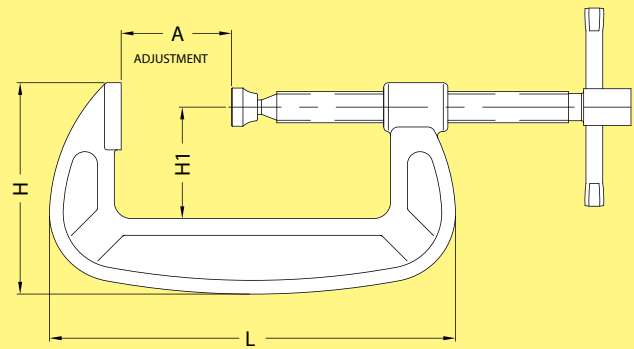

unit : mm

Model No.	H	H1	L	A	HOLDING CAPACITY	WEIGHT
C100	105	54	192	0.0~100	3000kg	1.4kg
C150	137	74	264	0.0~150	3600kg	3.1kg
C200	177	98	325	0.0~200	6000kg	4.5kg





# HEAVY DUTY CABINET



Model	Section	Column	Row	Drawer Unit	Dimension (mm)			Nett Weight (kg)	Holding Capacity (kg)
					W	D	H		
1. A3-2440	2	4	10	40	477	215	650	14.5	240
2. A3-2440R	2	4	10	40	477	215	650	14.5	240
3. A3-3460	3	4	15	60	477	215	950	21	360
4. A3-3460R	3	4	15	60	477	215	950	21	360

Ordering model (example): **A3 - 2440R**  
A3 Drawer      Section      Column      Oil Resistant      Drawer Unit

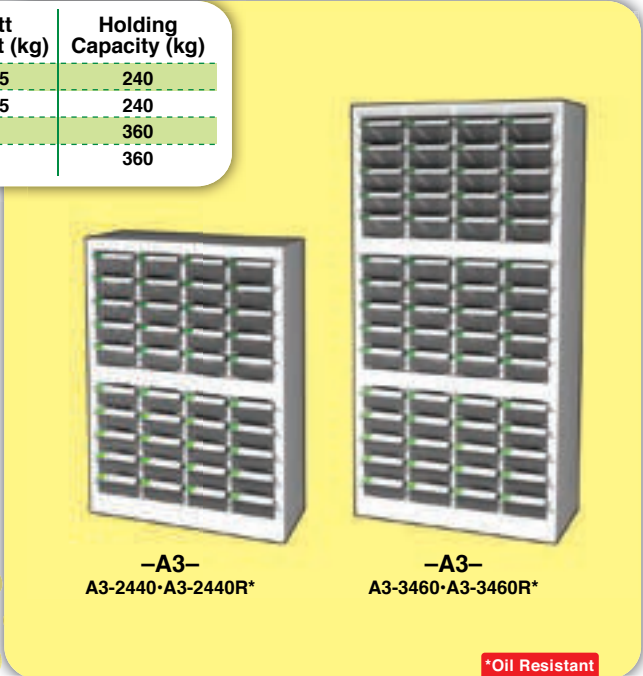

\*Oil Resistant

**JS SMALL PARTS CABINETS** provide convenient storage and orderly organized for all sort of small parts, Crystal-clear polystyrene drawers to permit quick visual inspection and picking of contents. Each smooth slide-gliding drawer has pull handle, two cross dividers to permit user to create any sizes required and label holder for marking purposes. Label cards and transparent protected covers are included. Drawer stoppers prevent accidental removal and spilling of contents. Cabinets are welded steel frame finished in rust-resistant epoxy powder coating of attractive mistgray. Cabinets can be arranged in row or stacked up on top of each other. For replacement of drawers, drawer track / support specify model No.

Model	Column	Row	Drawer Unit	Dimension (mm)			Nett Weight (kg)	Holding Capacity (kg)
				W	D	H		
1. F4-318T	3	6	18	477	235	401	9	216
2. F4-318R	3	6	18	477	235	401	9	216
3. F4-345T	3	15	45	477	235	950	23	540
4. F4-345R	3	15	45	477	235	950	23	540
5. F6-312T	3	4	12	477	235	401	9	216
6. F6-312R	3	4	12	477	235	401	9	216
7. F6-330T	3	10	30	477	235	950	23	540
8. F6-330R	3	10	30	477	235	950	23	540
9. G4-318T	3	6	18	558	315	403	14	216
10. G4-345T	3	15	45	558	315	950	30	540
11. G6-312T	3	4	12	558	315	403	14	216
12. G6-330T	3	10	30	558	315	950	30	540



Ordering model (example): **F4 - 318T**  
F4 Drawer      Column      Transparent      Drawer Unit

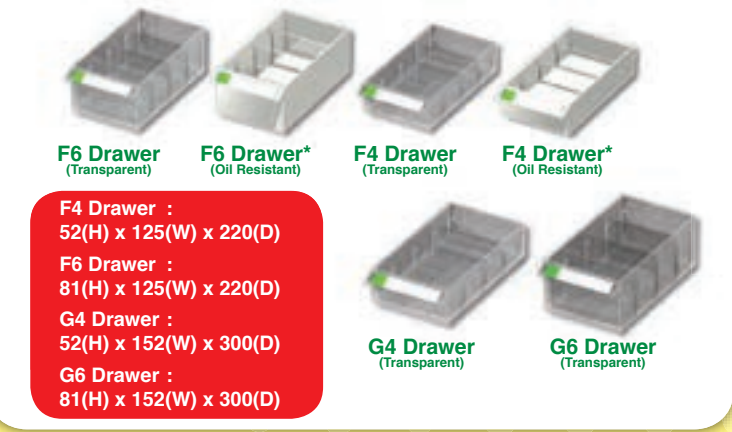

**F4 Drawer :**  
52(H) x 125(W) x 220(D)  
**F6 Drawer :**  
81(H) x 125(W) x 220(D)  
**G4 Drawer :**  
52(H) x 152(W) x 300(D)  
**G6 Drawer :**  
81(H) x 152(W) x 300(D)

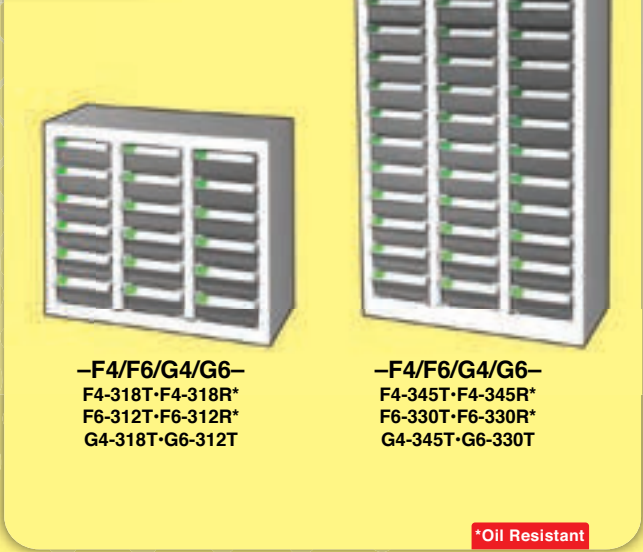

\*Oil Resistant



**REVOLVING  
PLATE**

**Model : RP160MDSH**

**\*Medium Duty**



This Revolving Plate is confirmed to the testing standard of functioning up to 15,000 rotation with 120kg center load.

**Weight : 1300g**

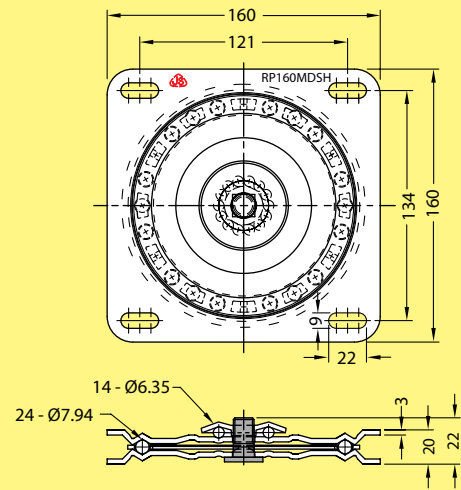

unit : mm

**Model : RP16023**

**\*Medium Duty**



This Revolving Plate is confirmed to the testing standard of functioning up to 15,000 rotation with 120kg center load.

**Weight : 1095g**

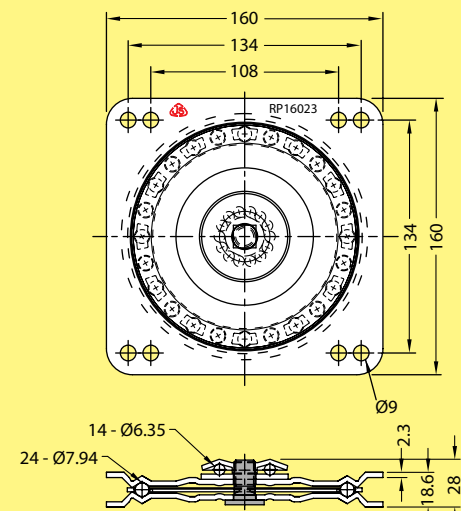

unit : mm

**Model : RP160MD**

**\*Medium Duty**



This Revolving Plate is confirmed to the testing standard of functioning up to 15,000 rotation with 120kg center load.

**Weight : 1370g**

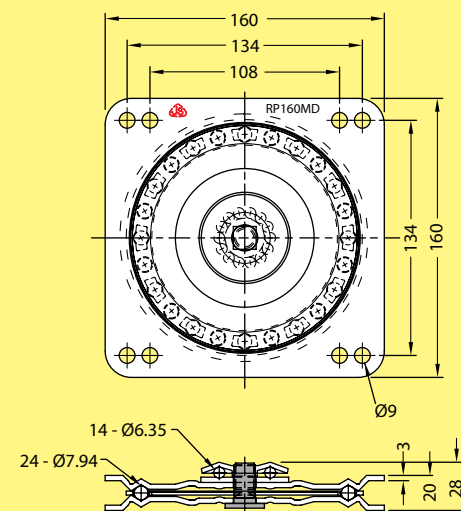

unit : mm

# REVOLVING PLATE



## Model : RP25023F

This **Revolving Plate** is confirmed to the testing standard of functioning up to **15,000** rotation with **210kg** center load.



Weight : 2434g

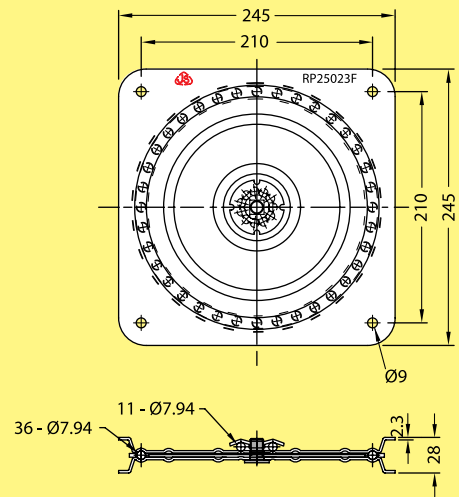

unit : mm



Revolving Plate

## Kung Fu Exercise Twister

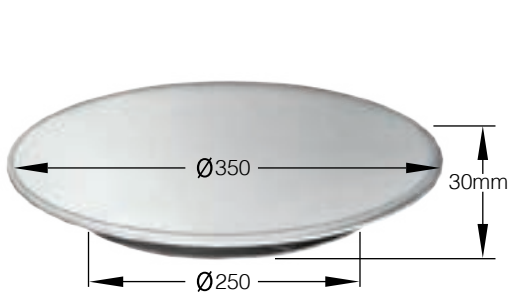

## Round Rack Footing



Model	A	B	C	H	T	Weight
1. RF25T150RD	150	126	65	29	2.5	249g
2. RF30T150RD	150	126	65	29	3.0	448g
3. RF40T170RD	167	135	76	39	4.0	831g
4. RF30T190RD	190	135	110	27	3.0	780g

Mat'l : M.S

Coating : NIL

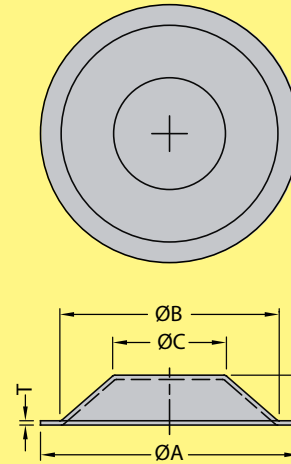

unit : mm

## Square Rack Footing

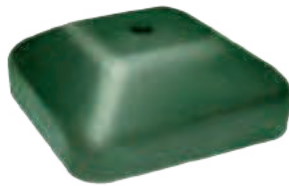

SQB-TYPE

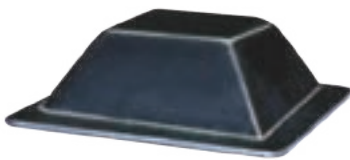

SQA-TYPE



### SQB-TYPE

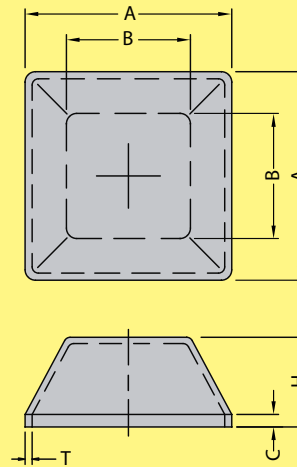

unit : mm

### SQA-TYPE

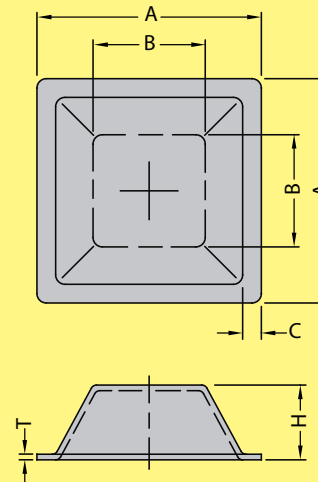

unit : mm

Model	A	B	C	H	T	Weight
1. RF30120SQA40	120	60	10	40	3.0	437g
2. RF40120SQA40	120	60	10	40	4.0	584g
3. RF40120SQB50	120	55	30	50	4.0	743g
4. RF40125SQA50	125	72	10	50	4.0	731g
5. RF45130SQA45	130	87	10	45	4.5	854g
6. RF40100SQB50	100	72	10	50	4.0	587g
7. RF40114SQA48	114	72	4	48	4.0	587g
8. RF30100SQA35	100	41	10	35	3.0	320g
9. RF30085SQB35	85	41	3	35	3.0	253g

Mat'l : M.S

Coating : NIL

## USAGE

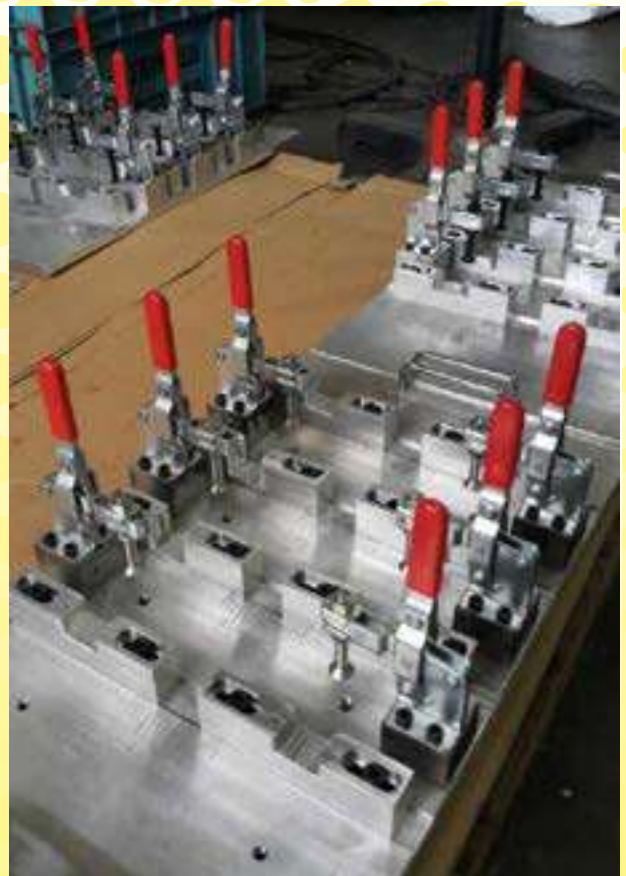



## MACHINE MOUNT & LEVEL ADJUSTER

### Machine Mount

#### JS High Performance Rubber

- Tensile strength 25 MPa
- Elongation at break max 900%
- Max temperature dry atmosphere 120°C
- Cold resistance -40°C
- Resistance to permanent set
- Abrasion resistance
- Tear resistance
- Rebound
- Resistance to oil and gasoline
- Resistance to hydrolysis, dilute alkali
- Resistance to gas permeability



Model	ØA	Adjustable Height (mm)	Bolt Thread Length (mm)	H1	H2	Capacity	Weight
1. MM-100-70	100	38 - 56	M12 x 120	31	44	1200kg	0.85kg
2. MM-140-70	140	45 - 65	M18 x 120	38	48	3000kg	2.00kg
3. MM-190-70	190	55 - 77	M24 x 180	41	60	4000kg	4.60kg
4. MM-250-70	250	74 - 109	M30 x 150	63	77	5000kg	10.5kg

#### Machine Mount

- (1) Screw Bolt
- (2) Locking Nut
- (3) Washer
- (4) Machine
- (5) Nitrile Rubber Pad
- (6) Support Housing
- (7) Bearing Plate

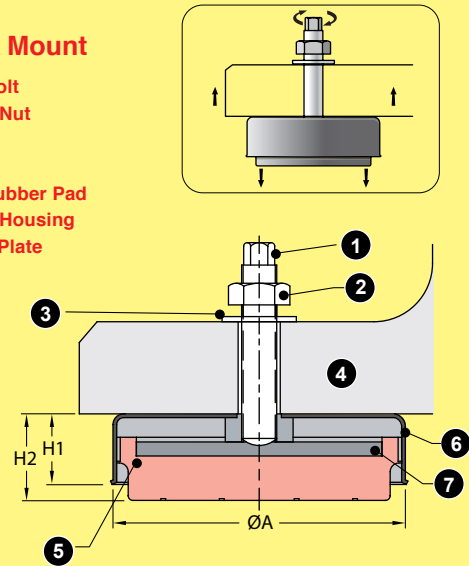

unit : mm

### Level Adjuster

#### Model : LA-1 (M8 or M10 x 33L)

\*Also available in Stainless Steel



Static Load : 90kg MAX

Weight : 27g/38.5g

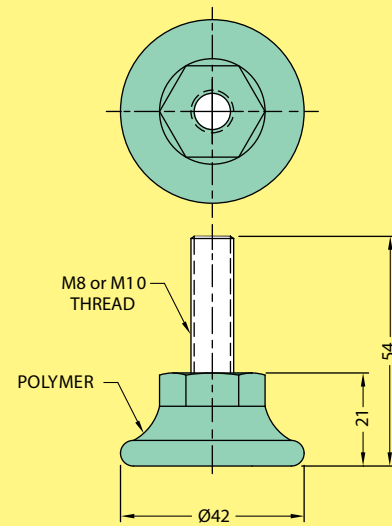

unit : mm

### Level Adjuster

\*Also available in Stainless Steel

**SPECIAL SIZES ORDER ARE WELCOME**



Model	MO	ØDO	L1	L2	L3	Weight	Static Load (kg)
1. LA-3	M8 or M10	Ø40	13	50	70	80g	350kg
2. LA-3	M12	Ø40	13	70	90	107g	350kg
3. LA-4	M16	Ø60	18	70	100	320g	500kg
4. LAR-4	M16	Ø60	18	70	105	320g	500kg
5. LA-5	M20	Ø80	26	83	126	551g	700kg
6. LAR-5	M16 or M20	Ø80	26	83	126	551g	700kg

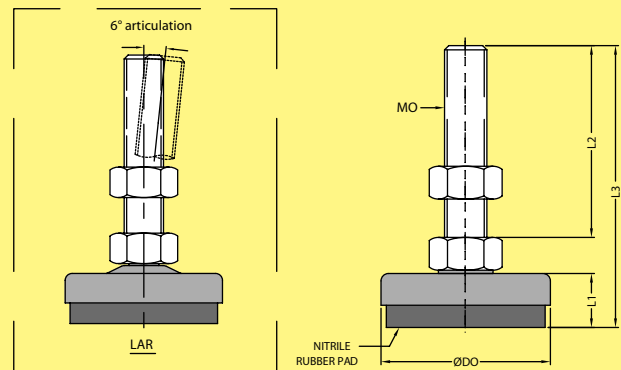

unit : mm

# HEAVY DUTY SQUARE MACHINE MOUNT



**JSCLAMP**  
HIGH QUALITY TOGGLE CLAMP

## Square Machine Mount

### JS High Performance Rubber

- Tensile strength 25 MPa
- Elongation at break max 900%
- Max temperature dry atmosphere 120°C
- Cold resistance -40°C
- Resistance to permanent set
- Abrasion resistance
- Tear resistance
- Rebound
- Resistance to oil and gasoline
- Resistance to hydrolysis, dilute alkali
- Resistance to gas permeability

#### Application:

For any machines subject to very highly dynamic disturbing force, such as punches, plastic injection, presses, shears, etc.

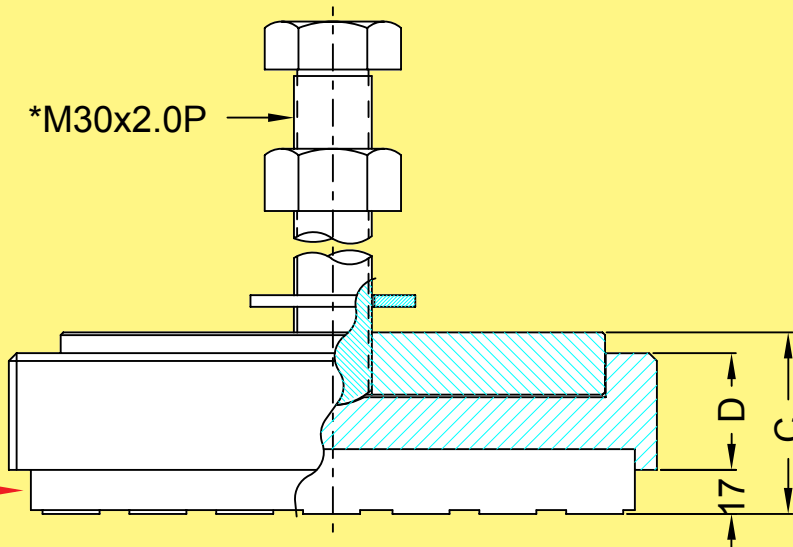

unit : mm

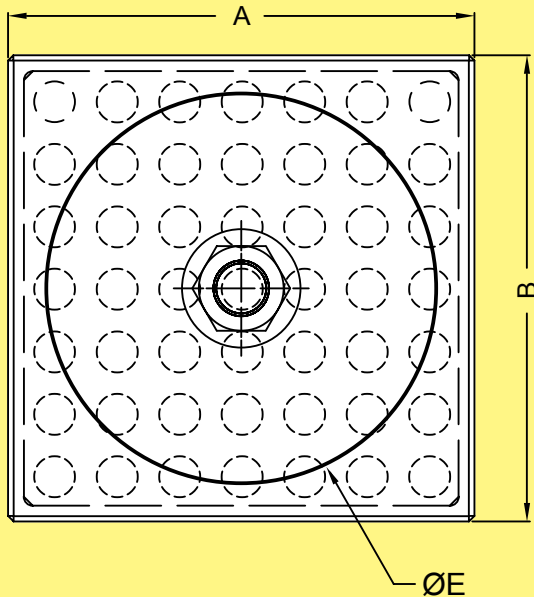

Model	A	B	C	D	ØE	Static Load
1. SMM-250250	250	250	70~85	45	210	8000kg
2. SMM-320320	320	320	75~90	50	280	14000kg
3. SMM-420420	420	420	80~100	60	360	25000kg

\*SPECIAL SIZES ORDER ARE WELCOME

unit : mm

## Anti-Slip Rubber Mats

### JS High Performance Rubber

#### FEATURES :

- Provides comfort and enhances overall health of people who stand at work
- Natural rubber formula provides drainage & anti-slip safety features
- 100% high grade grease resistant rubber
- Chemical, lubricant & solvent resistant
- Easily for clean-up and removal
- Cold resistance -70°C

#### APPLICATION:

Use in wet or dry work station, kitchen, machine shops, assembly lines, labs, sport & Gym center, packaging plants. It also will prevent your products from slipping during handling and transportation.



**ASRM-500500H**  
(For wet greasy work environments)



**ASRM-500500B**  
(For dry work environments)



### Usage: Work Shops



### Usage: Transportation



Model	Weight	Static Load
1. ASRM-500500H	5.2 kg	8 Ton
2. ASRM-500500B	6.4 kg	10 Ton

### Anti-Slip Rubber Mats

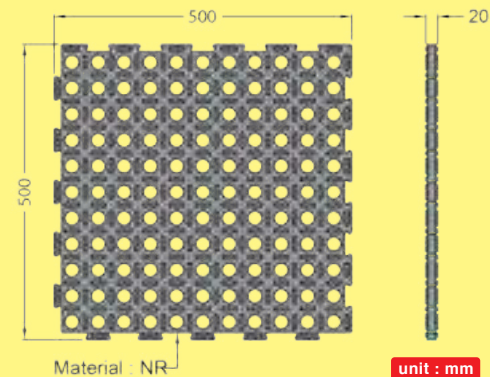



# HEAVY INDUSTRY ANTI-VIBRATION FLOOR MATS



## Anti-Vibration Floor Mats

### JS High Performance Rubber

- Tensile strength 25 MPa
- Elongation at break max 900%
- Max temperature dry atmosphere 120°C
- Cold resistance -40° C
- Resistance to permanent set
- Abrasion resistance
- Tear resistance
- Rebound
- Resistance to oil and gasoline
- Resistance to hydrolysis, dilute alkali
- Resistance to gas permeability

#### Application:

For any machines subject to very highly dynamic disturbing force, such as punches, plastic injection, presses, shears, lathe, milling, food industry machine, sport & Gym center, etc.

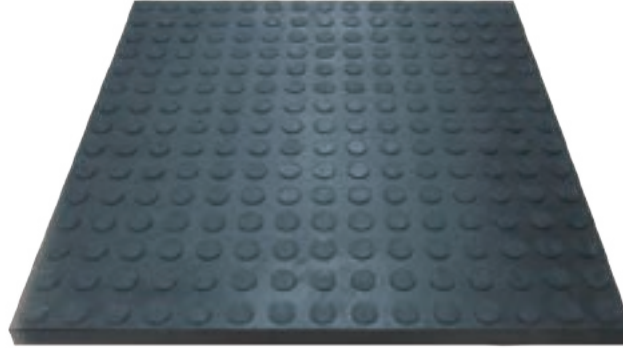

## Usage: All Kinds of Machines (Reduces noise & absorbs impact)

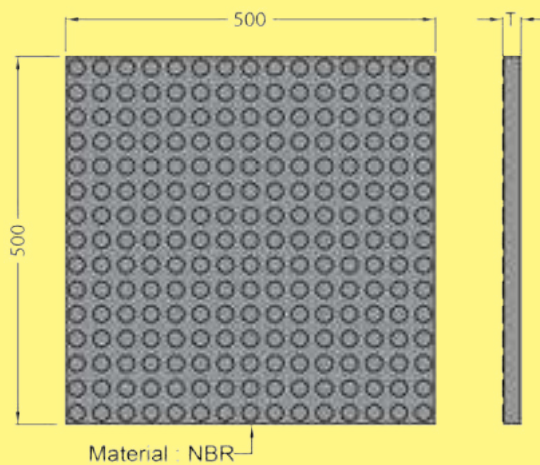

Model	T	Weight	Static Load
1. AVFM-500500T15	15	6.3 kg	20 Ton
2. AVFM-500500T20	20	8.6 kg	30 Ton
3. AVFM-500500T25	25	10.4 kg	40 Ton

**LEVELING MOUNT  
& LEVELING MOUNT  
(LONG BASE)**

Model	MO	ØDO	L1	L2	Weight	Static Load (kg)
1. LM-45B3860	3/8 BSW	Ø45	14	60	77g	350
2. LM-45M860	M8 x 1.25			60	65g	
3. LM-45M1060	M10 x 1.5			60	87g	
4. LM-45M1260	M12 x 1.75			60	110g	
5. LM-60M880	M8 x 1.25	Ø60	16	80	105g	700
6. LM-60M8100				100	110g	
7. LM-60M8120				120	115g	
8. LM-60M1080	M10 x 1.5	Ø60	16	80	127g	700
9. LM-60M10100				100	138g	
10. LM-60M10120				120	147g	
11. LM-60M1280	M12 x 1.75	Ø60	16	80	140g	700
12. LM-60M12100				100	169g	
13. LM-60M12120				120	185g	
14. LM-75B1275	1/2 BSW	Ø75	20	75	184g	1000
15. LM-75B12100				100	203g	
16. LM-75B12150				150	241g	
17. LM-75B5875	5/8 BSW	Ø75	20	75	258g	1000
18. LM-75B58100				100	288g	
19. LM-75B58150				150	347g	
20. LM-75M1275	M12 x 1.75	Ø75	20	75	167g	1000
21. LM-75M12100				100	185g	
22. LM-75M12150				150	223g	
23. LM-75M1675	M16 x 2.0	Ø100	25	75	238g	1500
24. LM-75M16100				100	270g	
25. LM-75M16150				150	337g	
26. LM-100B5875	5/8 BSW	Ø100	25	75	335g	1500
27. LM-100B58100				100	360g	
28. LM-100B58150				150	426g	
29. LM-100M1675	M16 x 2.0	Ø100	25	75	316g	1500
30. LM-100M16100				100	350g	
31. LM-100M16150				150	417g	

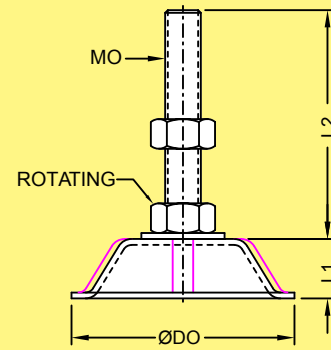
**Leveling Mount**

unit : mm

Also available in Stainless Steel

Mat'l : Mild Steel

Coating : Blue Zinc

\*Static load has been tested and verified by lab.

Model	MO	ØD	A	B	C	L1	L2	Weight	Static Load
1. LML-60M880	M8 x 1.25	Ø9	60	92	50	16	80	129 g	700 kg
2. LML-60M8100							100	136 g	
3. LML-60M8120							120	142 g	
4. LML-60M1080	M10 x 1.5	Ø9	60	92	50	16	80	156 g	700 kg
5. LML-60M10100							100	163 g	
6. LML-60M10120							120	176 g	
7. LML-60M1280	M12 x 1.75	Ø9	60	92	50	16	80	182 g	700 kg
8. LML-60M12100							100	194 g	
9. LML-60M12120							120	207 g	
10. LML-75B1275	1/2 BSW	Ø14	75	110	58	20	75	203 g	1000 kg
11. LML-75B12100							100	222 g	
12. LML-75B12150							150	254 g	
13. LML-75B5875	5/8 BSW	Ø14	75	110	58	20	75	258 g	1000 kg
14. LML-75B58100							100	308 g	
15. LML-75B58150							150	347 g	
16. LML-75M1275	M12 x 1.75	Ø14	75	110	58	20	75	186 g	1000 kg
17. LML-75M12100							100	202 g	
18. LML-75M12150							150	239 g	
19. LML-75M1675	M16 x 2.0	Ø14	75	110	58	20	75	258 g	1000 kg
20. LML-75M16100							100	292 g	
21. LML-75M16150							150	356 g	

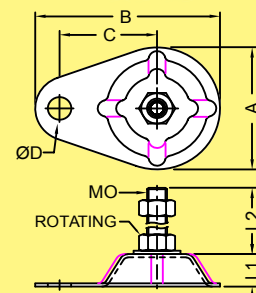
**Leveling Mount (Long Base)**

unit : mm

Also available in Stainless Steel

Mat'l : Mild Steel

Coating : Blue Zinc

# LEVELING FEET



Model	MO	ØD	C	ØP	H	L	L1	Weight (g)	Static Load (kg)
1. LF-60M1045	M10	Ø66	-	-	29	45	89	102	700
2. LF-60M1070						70	114	114	
3. LF-60M10100						100	144	129	
4. LF-60M1245	M12	Ø66	-	-	29	45	89	124	700
5. LF-60M1270						70	114	143	
6. LF-60M12100						100	144	164	
7. LF-80M1660	M16	Ø86	63	Ø8.5	30	60	108	259	1000
8. LF-80M16100						100	148	316	
9. LF-80M16140						140	188	367	
10. LF-80M16160	M16	Ø86	63	Ø8.5	30	160	208	392	1000
11. LF-100M1660						60	115	330	
12. LF-100M16100						100	155	375	
13. LF-100M16140	M16	Ø86	63	Ø8.5	30	140	195	427	1200
14. LF-100M16160						160	215	464	
15. LF-100M20100						100	155	525	
16. LF-100M20140	M20	Ø107	78	Ø10.4	38	140	195	610	1200
17. LF-100M20160						160	215	658	
18. LF-100M20200						200	255	740	

Also available in Stainless Steel

JS Leveling Feet can be used to level electronic racks, machine tools, benches, etc. The polyamide offer good impact resistance, high strength & good resistance to many organic acids, alkaline, chemical, salt, etc.

## Leveling Feet

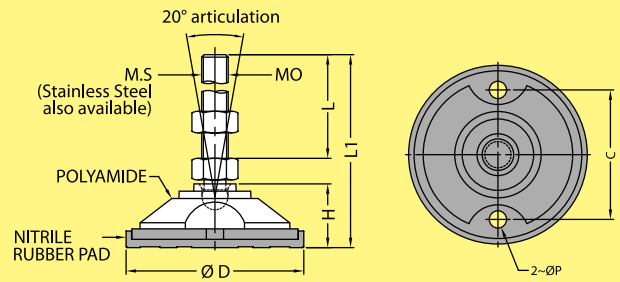
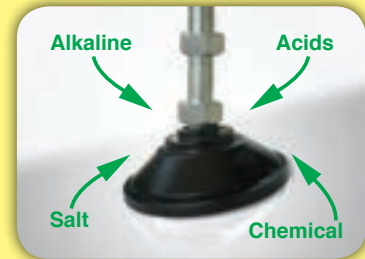

unit : mm

## Usage



## Leveling Element

### JS High Performance Rubber

- Tensile strength 25 MPa
- Elongation at break max 900 %
- Max temperature dry atmosphere 120 °C
- Cold resistance -40°C
- Resistance to permanent set
- Abrasion resistance
- Tear resistance
- Rebound
- Resistance to oil and gasoline
- Resistance to hydrolysis, dilute alkali
- Resistance to gas permeability

#### Application:

Cost-effective leveling element design & adequate vibration for packaging, chemical & pharmaceutical test equipment, measuring machines, pumps, generator, compressors, etc.

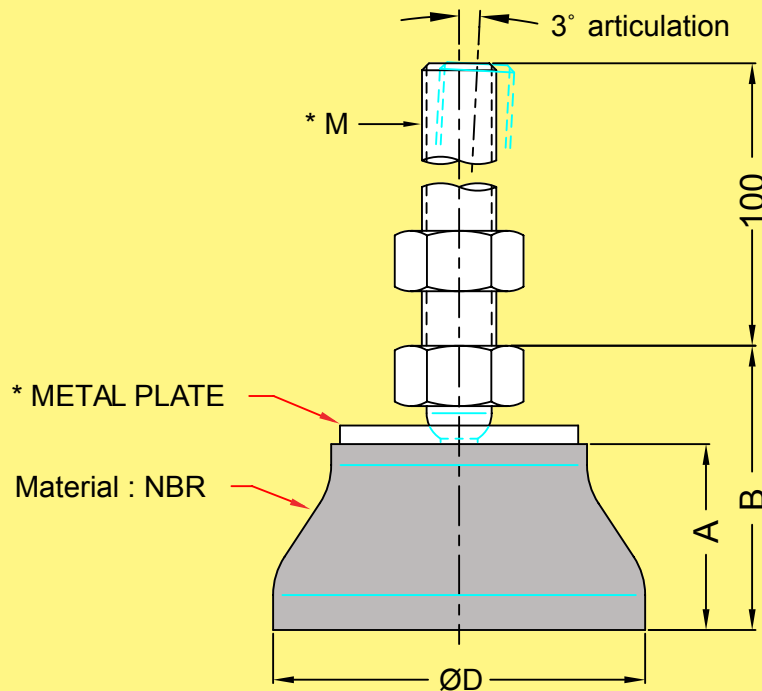

unit : mm

Model	ØD	M	A	B	Weight	Static Load
1. LERBR-60M16100	60	M16	33	51	348 g	400 kg
2. LERBR-60M20100		M20		54	484 g	
3. LERBR-80M16100	80	M16	40	61	511 g	700 kg
4. LERBR-80M20100		M20		63	649 g	
5. LERBR-100M16100	100	M16	49	70	772 g	1000 kg
6. LERBR-100M20100		M20		72	902 g	

\*SPECIAL SIZES ORDER ARE WELCOME (\*Also available in Stainless Steel)

# LEVELING ELEMENT & RUBBER PAD



## Leveling Element (Heavy Duty)

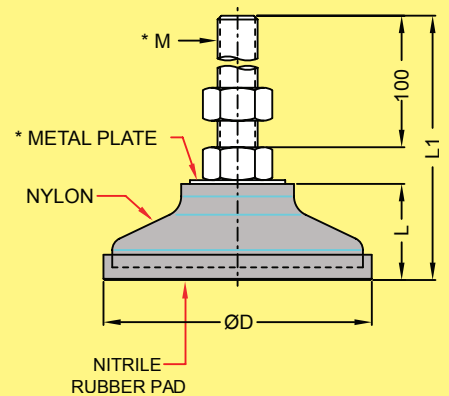
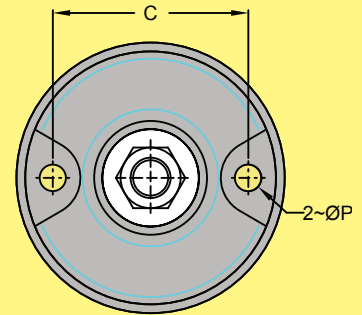

unit : mm

Model	M	ØD	ØP	C	L	L1	Weight	Static Load
1. LE-60M12100	M12						147.5	228 g
2. LE-60M16100	M16	Ø66	--	--	36.5	150.5	154	326 g
3. LE-60M20100	M20						154	461 g
4. LE-80M12100	M12						148.5	270 g
5. LE-80M16100	M16	Ø86	Ø8.5	63	37.5	151.5	155	368 g
6. LE-80M20100	M20						155	503 g
7. LE-100M12100	M12						149.5	332 g
8. LE-100M16100	M16	Ø107	Ø10.5	78	38.5	152.5	156	430 g
9. LE-100M20100	M20						156	565 g

\*SPECIAL SIZES ORDER ARE WELCOME (\*Also available in Stainless Steel)

Model	ØD	ØE	T	C	ØP	Weight
1. RBP - 45	Ø45	Ø51	3.5	--	--	13 g
2. RBP - 60	Ø60	Ø66	3.5	--	--	21 g
3. RBP - 75	Ø75	Ø81	3.5	--	--	33 g
4. RBP - 80	Ø80	Ø86	4.5	65	Ø8.5	48 g
5. RBP - 100	Ø100	Ø107	5.0	79	Ø10.5	77 g



## Rubber Pad

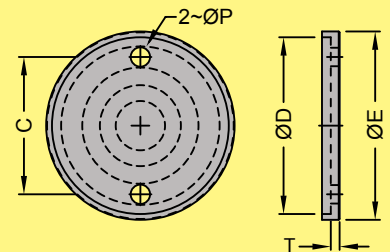

unit : mm

Material: Nitrile Rubber

Model	A	B	T	ØP	Weight
1. RBP-60-LML	60	92	3.5	Ø10	26g
2. RBP-75-LML	75	110	3.5	Ø14	42g



## Rubber Pad

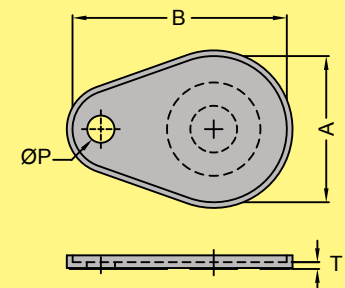

unit : mm

Material: Nitrile Rubber

**USAGE**



# BB DIE SET

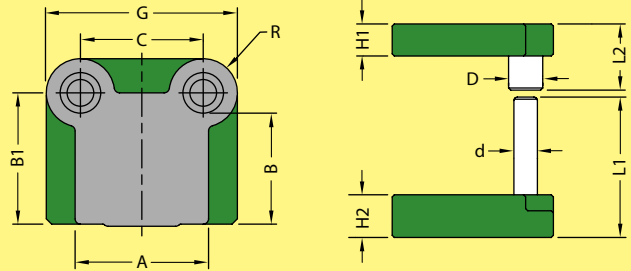

unit : mm

Size	A	B	H1	H2	d	D	L1	L2	C	B1	R	G
1. 80 x 80	80	80	25	35	22	32	130	57	70	100	26	122
2. 80 x 100	80	100	25	35	22	32	130	57	70	120	26	122
3. 100 x 80	100	80	25	35	22	32	130	57	90	100	26	122
4. 100 x 100	100	100	35	40	22	32	140	62	90	120	26	142
5. 100 x 125	100	125	30	40	22	38	140	62	90	148	32	154
6. 100 x 150	100	150	30	40	22	38	140	62	90	173	32	154
7. 125 x 80	125	80	30	40	22	32	140	62	115	100	32	179
8. 125 x 100	125	100	35	40	22	38	140	62	115	123	32	179
9. 125 x 125	125	125	35	40	22	38	140	62	115	148	32	179
10. 150 x 100	150	100	35	40	22	38	140	62	140	123	32	204
11. 150 x 125	150	125	35	40	22	38	140	62	140	148	32	204
12. 150 x 150	150	150	35	40	22	38	150	62	140	173	32	204
13. 150 x 180	150	180	35	40	25	38	150	62	140	208	32	204
14. 180 x 125	180	125	35	45	28	40	160	67	170	153	38	246
15. 180 x 150	180	150	35	45	28	40	160	67	170	178	38	246
16. 180 x 180	180	180	35	45	28	40	160	67	170	208	38	246
17. 210 x 100	210	100	35	45	25	38	150	62	200	123	32	264
18. 210 x 125	210	125	35	45	28	40	160	67	200	153	38	276
19. 210 x 150	210	150	35	45	28	40	160	67	200	178	38	276
20. 210 x 180	210	180	35	45	28	40	160	67	200	208	38	276
21. 210 x 210	210	210	35	45	28	40	160	67	200	238	38	276
22. 250 x 125	250	125	40	50	32	44	160	67	240	153	38	316
23. 250 x 150	250	150	40	50	32	44	160	67	240	178	38	316
24. 250 x 180	250	180	40	50	32	44	160	67	240	208	38	316
25. 250 x 210	250	210	40	50	32	44	160	67	240	238	38	316
26. 250 x 250	250	250	45	55	32	44	180	77	240	278	38	316
27. 300 x 125	300	125	40	55	32	44	180	77	290	153	38	366
28. 300 x 150	300	150	40	55	32	44	180	77	290	178	38	366
29. 300 x 180	300	180	40	55	32	44	180	77	290	208	38	366
30. 300 x 210	300	210	40	55	32	44	180	77	290	238	38	366
31. 300 x 250	300	250	40	55	32	44	180	77	290	278	38	366
32. 300 x 300	300	300	40	55	32	44	180	77	290	328	38	366
33. 350 x 150	350	150	45	55	32	44	180	77	340	178	38	416
34. 350 x 210	350	210	45	55	32	44	180	77	340	238	38	416
35. 350 x 250	350	250	45	55	32	44	180	77	340	278	38	416



## ANTI-VIBRATION MOUNT

### JS High Performance Rubber

- Tensile strength 25 MPa
- Elongation at break max 900%
- Max temperature dry atmosphere 120°C
- Cold resistance -40°C
- Resistance to permanent set
- Abrasion resistance
- Tear resistance
- Rebound
- Resistance to oil and gasoline
- Resistance to hydrolysis, dilute alkali
- Resistance to gas permeability



Ordering model (example):

**TTC D x H**  
Type Diameter Height

The mount can be used effectively whenever anti-vibration are needed. They are suitable for use in both compression and shear application.

Application include mountings on engine, generator, compressor, air conditioner, motor, blower, electrical controller, laboratory equipment and other business industry machinery. The rubber is excellent to rebound, excellent resistance to abrasion, tear, permanent set hydrolysis and dilute alkali.

Model	D	D1	H	L	d	Load (kg)	Weight (g)
01. HHS 30-25	30	-	25	-	M8 x 1.25	40	45
02. HHS 40-28	40	-	28	-	M10 x 1.5	60	80
03. HBS 30-25	30	-	25	-	M8 x 1.25	40	40
04. HBS 40-28	40	-	28	-	M10 x 1.5	60	65
05. HHC 30-25	30	22	25	-	M8 x 1.25	40	40
06. HHC 40-28	40	26	28	-	M10 x 1.5	60	66
07. HHC 60-36	60	36.5	36	-	M10 x 1.5	90	178
08. HHC 60-43	60	36.5	43	-	M10 x 1.5	70	200
09. HHC 60-60	60	52	60	-	M10 x 1.5	150	324
10. HHC 70-56	70	50	56	-	M12 x 1.75	220	558
11. HHC 80-65	80	70	65	-	M12 x 1.75	500	860
12. HHC 90-50	90	80	50	-	M12 x 1.75	800	946
13. HHC 90-77	90	80	77	-	M12 x 1.75	500	1172
14. HHC 108-85	108	95	85	-	M16 x 2.0	800	1745
15. HHC 130-96	130	117	96	-	M16 x 2.0	1400	2734
16. TTS 20-20	20	-	20	18	M6 x 1.0	12	26
17. TTS 30-25	30	-	25	20	M8 x 1.25	40	62
18. TTS 40-28	40	-	28	25	M10 x 1.5	60	114
19. TBS 20-23	20	-	23	12	M6 x 1.0	12	20
20. TBS 30-25	30	-	25	20	M8 x 1.25	40	42
21. TBS 40-28	40	-	28	25	M10 x 1.5	60	84
22. TTC 20-20	20	14	20	18	M6 x 1.0	12	26
23. TTC 30-25	30	22	25	20	M8 x 1.25	40	56
24. TTC 40-28	40	26	28	25	M10 x 1.5	60	104
25. TTC 60-36	60	36.5	36	30	M10 x 1.5	90	212
26. TTC 60-43	60	36.5	43	30	M10 x 1.5	70	236
27. TTC 60-60	60	52	60	30	M10 x 1.5	150	370
28. TTC 70-56	70	50	56	35	M12 x 1.75	220	534
29. TTC 80-65	80	70	65	35	M12 x 1.75	500	805
30. TTC 90-50	90	80	50	45	M16 x 2.0	800	1068
31. TTC 90-77	90	80	77	45	M16 x 2.0	500	1288
32. TTC 108-85	108	95	85	45	M16 x 2.0	800	1896
33. TTC 130-96	130	117	96	45	M16 x 2.0	1400	2892
34. THC 130-96	130	117	96	45	M16 x 2.0	1400	2770

### HHS

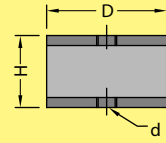

### HBS

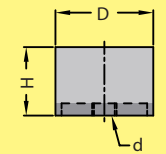

### HHC

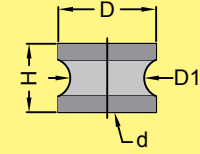

### TTS

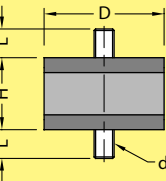

### TBS

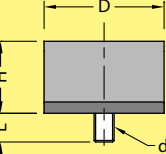

### TTC

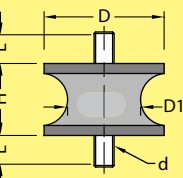

### THC

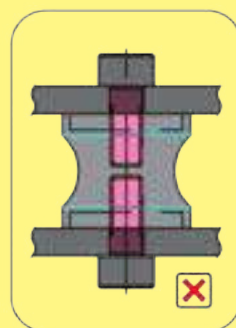
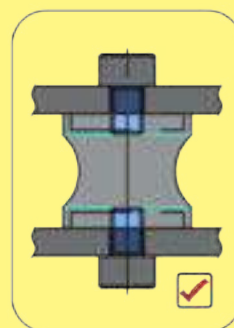
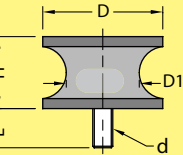

unit : mm



# LONG BASE ANTI-VIBRATION MOUNT



the P560, 570 model the handle is push up to trigger the clamp out

### JS High Performance Rubber

- Tensile strength 25 MPa
- Elongation at break max 900%
- Max temperature dry atmosphere 120°C
- Cold resistance -40° C
- Resistance to permanent set
- Abrasion resistance
- Tear resistance
- Rebound
- Resistance to oil and gasoline
- Resistance to hydrolysis, dilute alkali
- Resistance to gas permeability

#### Application:

Cost-effective leveling element design & adequate vibration for packaging, chemical & pharmaceutical test equipment, measuring machines, pump, generator, compressors, etc.

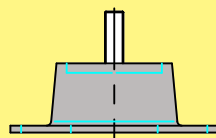

T - Type

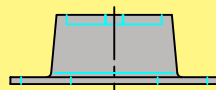

H - Type

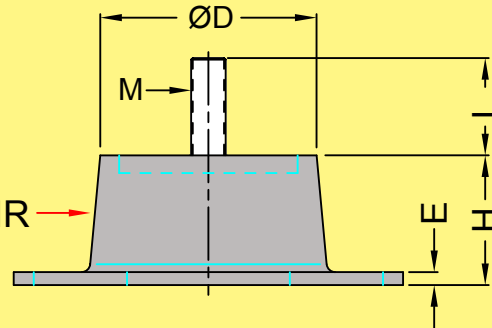
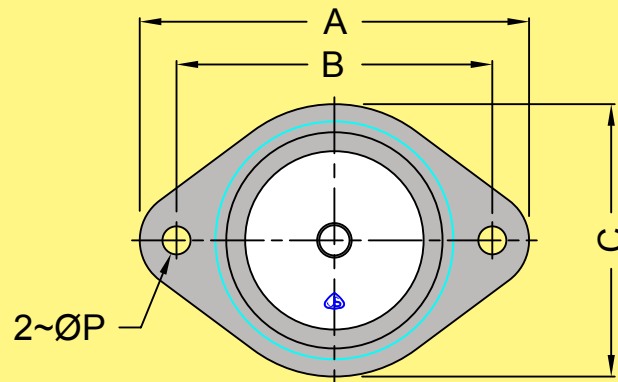

Material : NR

Model	M	ØD	ØP	A	B	C	E	H	L	Weight	Static Load
1. LBAVM-607440M10T								40	30	495 g	80 kg
2. LBAVM-607440M10H	M10	Ø60	Ø11	135	104	85	6		--	476 g	
3. LBAVM-607460M10T								60	30	583 g	160 kg
4. LBAVM-607460M10H									--	560 g	
5. LBAVM-809045M12T								45	35	790 g	400 kg
6. LBAVM-809045M12H	M12	Ø80	Ø13	159	126	104	6		--	813 g	
7. LBAVM-809065M12T								65	35	952 g	500 kg
8. LBAVM-809065M12H									--	960 g	
9. LBAVM-10011060M16T								60	45	1394 g	600 kg
10. LBAVM-10011060M16H	M16	Ø100	Ø13	180	146	126	6		--	1340 g	
11. LBAVM-10011080M16T								80	45	1636 g	800 kg
12. LBAVM-10011080M16H									--	1563 g	

### JS Standard SKD Straight Round Punch

Size		Length (L)								
ØD	ØH	40	50	60	70	80	90	100	120	
1. 1.0	1.6	0	0	0						
2. 1.5	2	0	0	0						
3. 2.0	4	0	0	0	0	0				
4. 2.5	4.5	0	0	0	0	0				
5. 3.0	5	0	0	0	0	0	0	0		
6. 3.5	5.5	0	0	0	0	0				
7. 4.0	7	0	0	0	0	0	0	0		
8. 4.5	7.5	0	0	0	0	0				
9. 5.0	8	0	0	0	0	0	0	0		
10. 5.5	8.5	0	0	0	0	0	0	0		
11. 6.0	9	0	0	0	0	0	0	0		
12. 6.5	9.5	0	0	0	0	0	0	0		
13. 7.0	10	0	0	0	0	0	0	0		
14. 8.0	11	0	0	0	0	0	0	0	0	
15. 9.0	12	0	0	0	0	0	0	0	0	
16. 10	13	0	0	0	0	0	0	0	0	
17. 11	14		0	0	0	0	0	0	0	
18. 12	15		0	0	0	0	0	0		
19. 13	16		0	0	0	0	0	0		
20. 14	17		0	0	0	0	0	0		
21. 15	18		0	0	0	0	0	0		
22. 16	19		0	0	0	0	0	0	0	
23. 18	21		0	0	0	0	0	0	0	
24. 20	23		0	0	0	0	0	0	0	
25. 25	28		0	0	0	0	0	0	0	

Ordering model (example): **SKD - Ø20x70L - 7PCS**

Material    ØD    Length    QTY

Material : SKD - 11 (XW-5)  
 Hardness : HRC 60° - 63°  
 O : Ready Stock

\*Special size orders are welcome



SKD

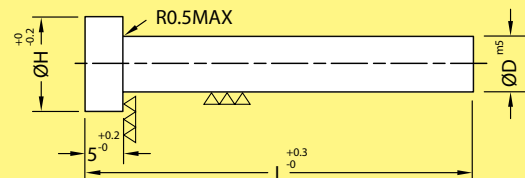

unit : mm

### JS Standard High Speed Straight Round Punch

Size		Length (L)							
ØD	ØH	40	50	60	70	80	90	100	
1. 1.0	1.6	0	0	0					
2. 1.5	2	0	0	0					
3. 2.0	4	0	0	0	0	0			
4. 2.5	4.5	0	0	0	0	0			
5. 3.0	5	0	0	0	0	0	0	0	
6. 3.5	5.5	0	0	0	0	0			
7. 4.0	7	0	0	0	0	0	0	0	
8. 4.5	7.5	0	0	0	0	0			
9. 5.0	8	0	0	0	0	0	0	0	
10. 5.5	8.5	0	0	0	0	0	0	0	
11. 6.0	9	0	0	0	0	0	0	0	
12. 6.5	9.5	0	0	0	0	0	0	0	
13. 7.0	10	0	0	0	0	0	0	0	
14. 8.0	11	0	0	0	0	0	0	0	
15. 9.0	12	0	0	0	0	0	0	0	
16. 10	13	0	0	0	0	0	0	0	
17. 11	14		0	0	0	0	0	0	
18. 12	15		0	0	0	0	0	0	
19. 13	16		0	0	0	0	0	0	
20. 14	17		0	0	0	0	0	0	
21. 15	18		0	0	0	0	0	0	
22. 16	19		0	0	0	0	0	0	
23. 18	21		0	0	0	0	0	0	
24. 20	23		0	0	0	0	0	0	
25. 25	28		0	0	0	0	0	0	

Ordering model (example): **SKH - Ø20x70L - 7PCS**

Material    ØD    Length    QTY

Material : SKH - 51  
 Hardness : HRC 61° - 64°  
 O : Ready Stock

\*Special size orders are welcome



SKH

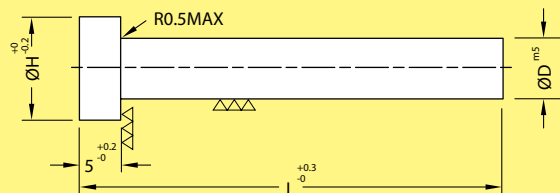

unit : mm

**STAMPING SAFETY  
TOOL & DEAD  
BLOW HAMMER**



**Stamping Safety Tool**

Model : SST-15RT

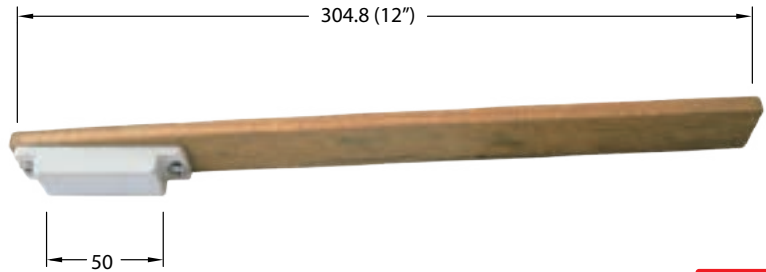

Holding Capacity : 1.5kg | Weight : 85g

unit : mm

**Stamping Safety Tool**

Model : SST-30RT



Holding Capacity : 3kg | Weight : 102g

unit : mm

**Stamping Safety Tool**



Model	Ø D	H	L	HOLDING CAPACITY	WEIGHT
SST - 1	19	19	230	1Kg	134g
SST - 2	19	19	230	2Kg	126g
SST - 3	22	19	228	3Kg	140g
SST - 4	28	26	235	4Kg	208g

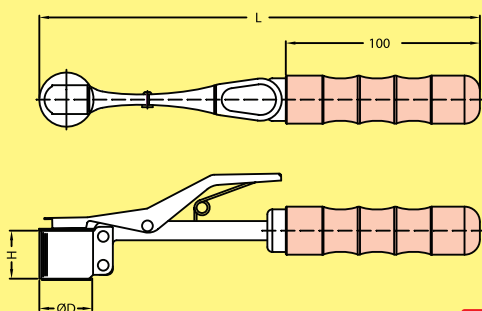

unit : mm

**Dead Blow Hammer**

Model : JSH-3



Weight : 923g



Material: NBR

unit : mm



**Model : MV25T**



Load Capacity: 25 ton each

Weight : 18.5kg

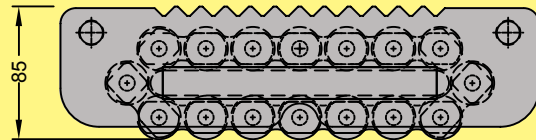
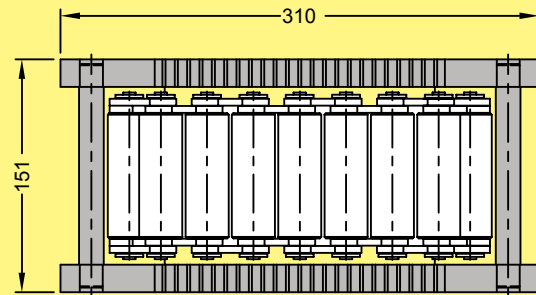

Rental Available

unit : mm

**Model : MVF3263**



Load Capacity: 35 ton each

Weight : 27.6kg

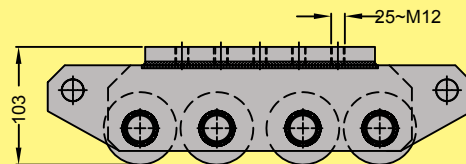
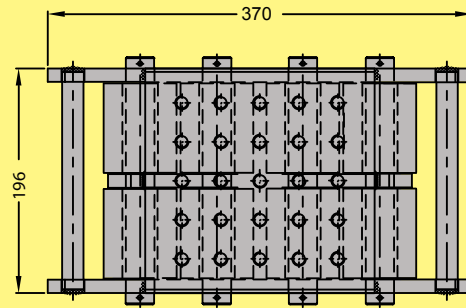

Rental Available

unit : mm

**Model : MVR3263**



Load Capacity: 35 ton each

Weight : 29.8kg

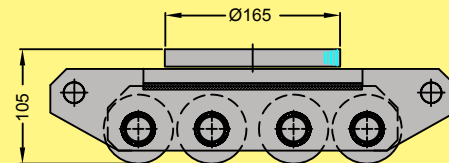
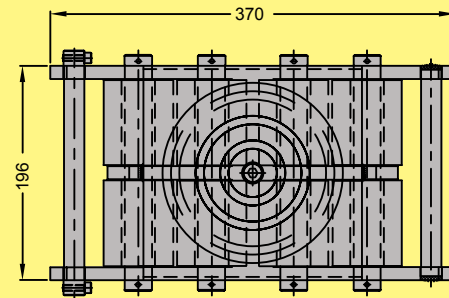

Rental Available

unit : mm

**KUNGFU  
STAINLESS STEEL  
RING**



**Kungfu Stainless Steel Ring**



Weight : 756g  
Mat'l : SUS 304

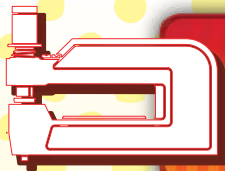
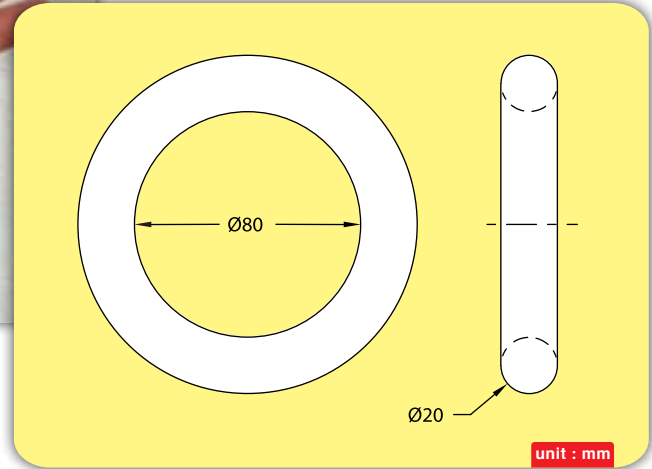

**UNIPUNCH**

**Unipunch**

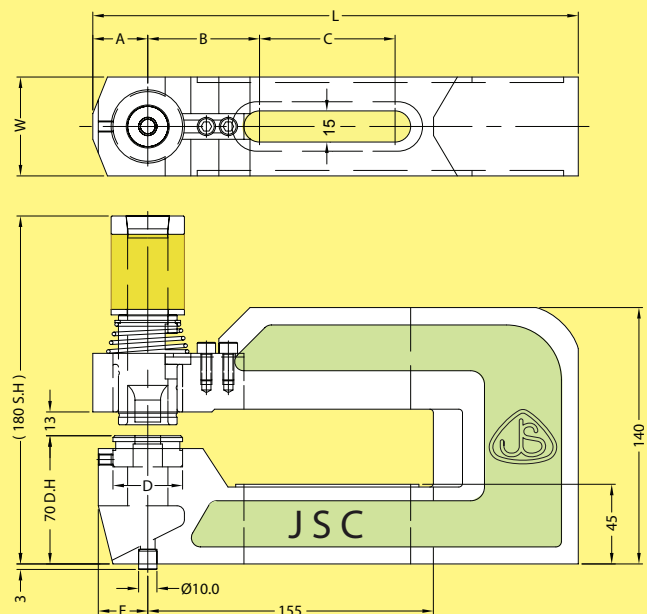

Model	A	B	C	D	E	W	L	PUNCH CAPACITY	MAT'L THICK.	BODY WEIGHT
A-1-150	23	57	76	28	20	48	253	Ø2.5-Ø11.9	6.0 max	7 kg
A-2-150	30	61	74	38	27	54	265	Ø12.0-Ø21.5	6.0 max	9 kg
A-3-150	40	67	69	50	34	68	280	Ø22.0-Ø25.0 Ø26.0-Ø30.0	6.0 max 4.5 max	12 kg
A-4-150	50	75	61	63	45	89	290	Ø31.0-Ø40.0	3.2 max	16 kg
A-5-150	55	71	58	78	50	98	305	Ø41.0-Ø50.0	3.2 max	20 kg



## Pneumatic Rotary Index Table



### Usage

Model	JS-RIT-280-90	JS-RIT-280-60	JS-RIT-280-45	JS-RIT-280-30	JS-RIT-280-15
ROTATE ANGEL	90°	60°	45°	30°	15°
ROTATE DIRECTION	Clock Wise	Clock Wise	Clock Wise	Clock Wise	Clock Wise
MAX. INDEXING LOAD (kg)	45kg	45kg	45kg	45kg	45kg
MAX. LINE PRESSURE (PSI)	20PSI	20PSI	20PSI	20PSI	20PSI
MAX. RECM'D LINE PRESSURE (PSI)	80PSI	80PSI	80PSI	80PSI	80PSI
WEIGHT (kg)	27kg	27kg	27kg	27kg	27kg

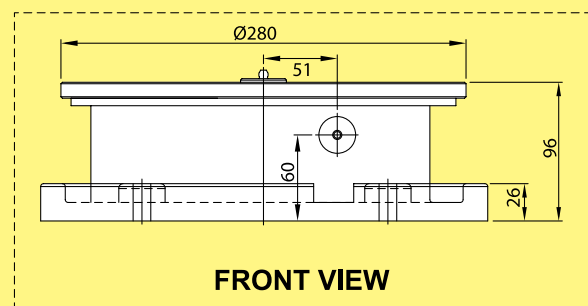
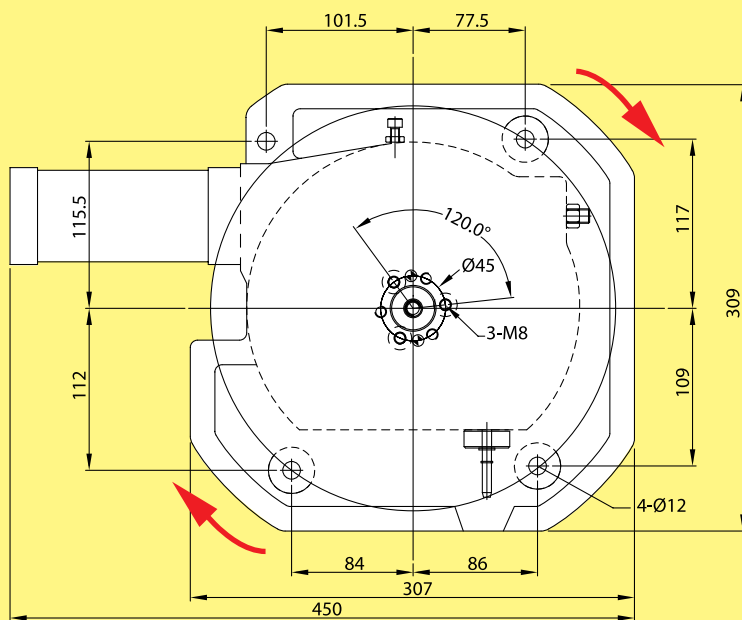

unit : mm

NOTES





## CNC TOOLS TROLLEY

Overall Dimension (mm) : 410D x 615W x 860H

Tray Size (mm) : 365D x 570W x 75H

### CNC Tools Trolley

Model : CT - BT4015

Weight : 22.9kg



### CNC Tools Trolley

Model : CT - BT4030

Weight : 24.7kg



Holding Capacity - 210 kg

## ADAPTOR (BT-40)

Mat'l : NBR

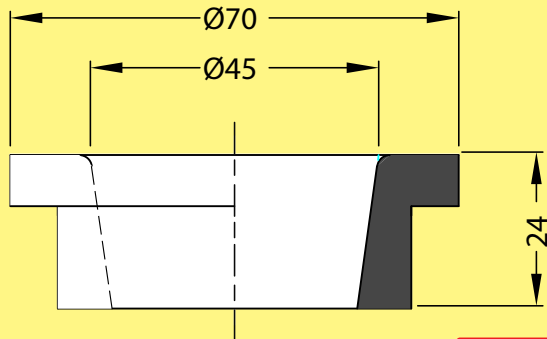

unit : mm



### Installation Instruction:



STEP-1



STEP-2



STEP-3



COMPLETED



TROLLEY



## Heavy Duty 3 Layer Universal Trolley

Overall Dimension (mm) : 410D x 615W x 860H

Tray Size (mm) : 365D x 570W x 75H

Gross Weight : 20.6kg

### Heavy Duty 3 Layer Universal Trolley

Model : UT3-1



Weight : 20.6kg

Holding Capacity - 210kg



Optional : Plywood



Heavy Duty

#### Installation Instruction:



STEP 1



STEP 2



STEP 3



STEP 4



COMPLETED



**HAND KNOB**
**Hand Knob**
**EXTRA  
SOLID**

MODEL	M	ØD	H	H1	L	Weight (g)				
1. HKM-40M620	M6x1.0P	40	23	13	20	22g				
2. HKM-40M630					30	24g				
3. HKM-40M640					40	26g				
4. HKM-40M650					50	28g				
5. HKM-40M820	M8x1.25P	40	23	13	20	29g				
6. HKM-40M830					30	32g				
7. HKM-40M840					40	35g				
8. HKM-40M850	M8x1.25P	40	23	13	50	38g				
9. HKM-50M820					M8x1.25P	50	32	15	20	35g
10. HKM-50M830									30	37g
11. HKM-50M840									40	41g
12. HKM-50M850	M10x1.5P	50	32	15	50	44g				
13. HKM-50M1020					M10x1.5P	50	32	15	20	47g
14. HKM-50M1030									30	51g
15. HKM-50M1040									40	56g
16. HKM-50M1050	M10x1.5P	50	32	15	50	61g				
17. HKM-50M1060					60	67g				
18. HKM-63M1020					M10x1.5P	63	40	20	20	73g
19. HKM-63M1030	30	78g								
20. HKM-63M1040	40	83g								
21. HKM-63M1050	50	88g								
22. HKM-63M1060	M12x1.75P	63	40	20	60	92g				
23. HKM-63M1220					M12x1.75P	63	40	20	20	88g
24. HKM-63M1230									30	95g
25. HKM-63M1240									40	101g
26. HKM-63M1250	M12x1.75P	63	40	20	50	108g				
27. HKM-63M1260					60	116g				

\*Also available in stainless steel

MODEL	ØD	H	H1	M x Depth	Weight (g)
1. HKF-40M6SS	40	23	13	M6 x 15 Depth	27g
2. HKF-40M8SS				M8 x 15 Depth	24g
3. HKF-50M6SS	50	32	15	M6 x 20 Depth	40g
4. HKF-50M8SS				M8 x 20 Depth	36g
5. HKF-50M10SS	50	32	15	M10 x 20 Depth	45g
6. HKF-63M10SS				63	40
7. HKF-63M12SS	M12 x 24 Depth	68g			

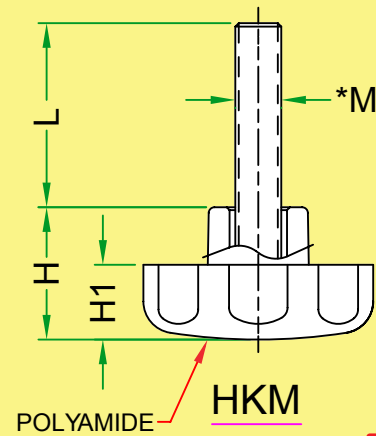
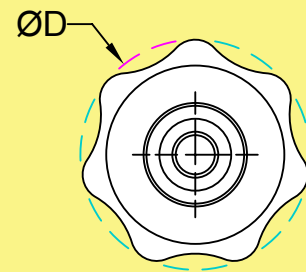
The polyamide offer good impact resistance, high strength &amp; good resistance to many organic acids, alkaline, chemical, salt, etc.



unit : mm

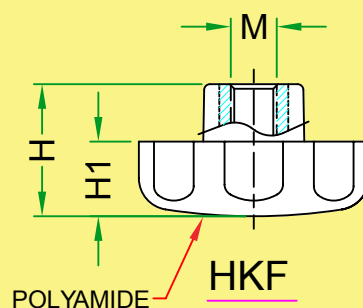

unit : mm

PLASTIC PULL  
HANDLE

Plastic Pull Handle

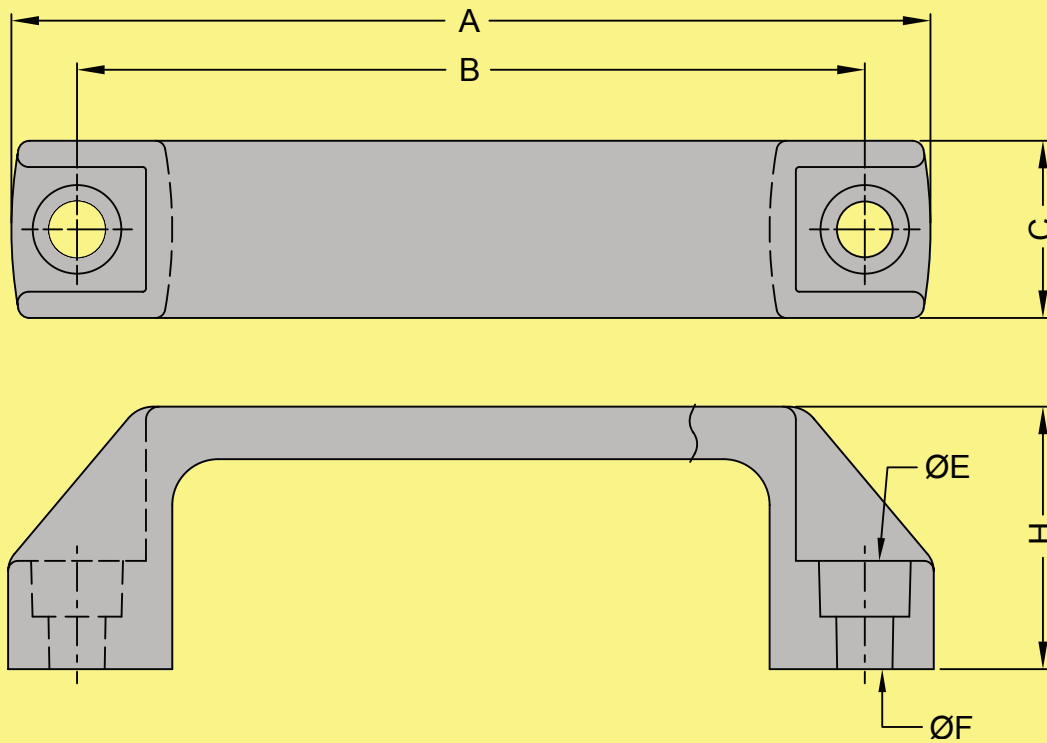

Material: PP Copolymer

Model	A	B	C	H	ØE	ØF	Weight
1. PPH - 90	112	90	21	36	11.5	6.5	27 g
2. PPH - 120	140	120	27	40	13.5	8.5	50 g
3. PPH - 150	170	150	27	46	13.5	8.5	56 g
4. PPH - 180	202	180	27	51	13.5	8.5	70 g



NOTES





TRAFFIC LIGHT



PETROL STATION



**JSclamp**

Manufacturer & Exporter

**Hup Ngai Industry Sdn Bhd**

No 161, Jln 27, Kaw 16, Sungai Rasa,  
41300 Klang, Selangor, Malaysia.

Tel : +603-3342 4377 / 8

Fax : +603-3342 8166

Email : jsclamp2008@yahoo.com

info@jsclamp.com

Website: www.jsclamp.com

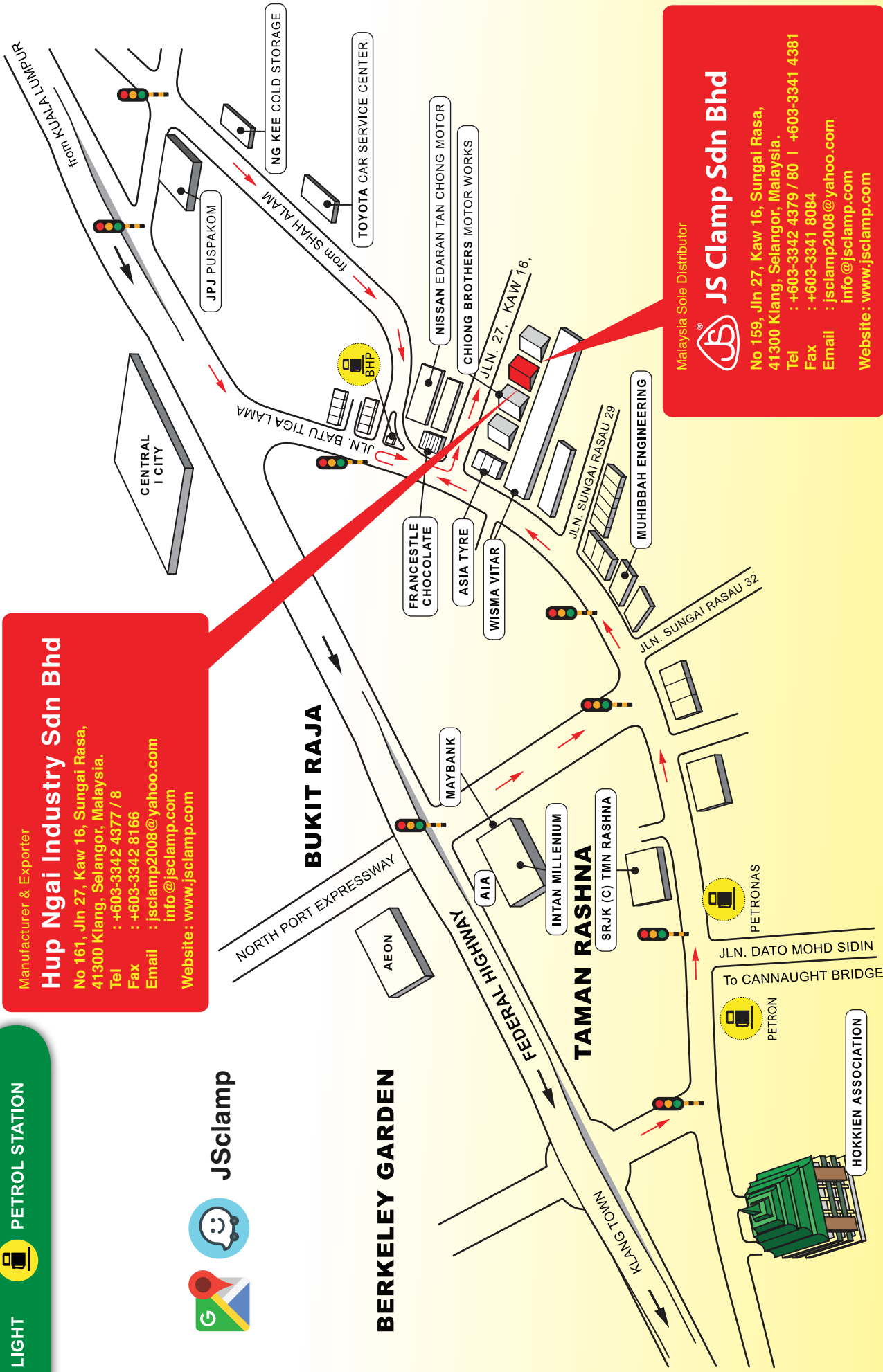

Malaysia Sole Distributor



**JS Clamp Sdn Bhd**

No 159, Jln 27, Kaw 16, Sungai Rasa,  
41300 Klang, Selangor, Malaysia.

Tel : +603-3342 4379 / 80 | +603-3341 4381

Fax : +603-3341 8084

Email : jsclamp2008@yahoo.com

info@jsclamp.com

Website: www.jsclamp.com

**INTERNATIONAL  
DISTRIBUTORS**



**THAILAND**

Philippines Sole Distributor  
**AMMEX Machine Tools Phils, Inc.**

Address: 27 Judge Juan Luna St., Del Monte,  
Quezon City Philippines 1105.  
Tel: (02) 352-8710 / (02) 709-9788  
Fax: (02) 352-8698  
Email: ammexmachine@yahoo.com /  
ammex921@yahoo.com  
Website: www.ammexmachine.com

Thailand Sole Distributor  
**NAS Equipment Co., Ltd.**

Address: 290, 292 Soi Chan 32, Chan Road,  
Thung Wat Don, Sathorn, Bangkok 10120, Thailand.  
Tel: +66-2675 5415 7  
Fax: +66-2675 5418  
Email: nas@thainas.com  
Website: www.thainas.com

**PHILIPPINES**

Malaysia Sole Distributor  
 **JS Clamp Sdn Bhd**

Address: No.159, Kaw 16, Sungai Rasa,  
41300 Klang, Selangor D.E., Malaysia.  
Tel: +603-3342 4379 / 801 +603-3341 4381  
Fax: +603-3341 8084  
Email: jsclamp2008@yahoo.com | info@jsclamp.com  
Website: www.jsclamp.com

**MALAYSIA**

**INDONESIA**

Indonesia Sole Distributor  
**PT. Riyadi Putra Makmur**

Address: Wisma 47 Jl. Cideng Barat No.47 Cideng,  
Jakarta Pusat 10150 Indonesia.  
Tel: +6221-6309 518 / 6306 669  
Fax: +6221-6309 638  
Email: rgunawan@riyadi.co.id  
Website: www.riyadi.co.id



# JS CLAMP

HIGH QUALITY TOGGLE CLAMP

## HIGH QUALITY ANTI-VIBRATION AND LEVELING ELEMENT



Machine Mount



Leveling Feet



Leveling Element  
Nylon Base



Leveling Element  
Rubber Base



Heavy Industry-large  
Machinery Anti-vibration  
Floor Mat

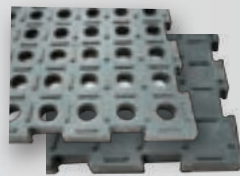

Industry Anti-slip  
Rubber Mats



Leveling Mount



Rubber pad



Anti-Vibration  
Mount



Long Base  
Anti-vibration mount



Leveling Mount  
Long Base



Level Adjuster

Manufacturer & Exporter:

**HUP NGAI INDUSTRY SDN BHD** (659871-D)  
No.161, Jalan 27, Kawasan 16, Sungai Rasa,  
41300 Klang, Selangor Darul Ehsan, Malaysia.  
☎ +603-3342 4377 / 8 | 📠 +603-3342 8166

Malaysia Sole Distributor:

**JS CLAMP SDN BHD** (718880-X)  
No.159, Jalan 27, Kaw 16, Sungai Rasa,  
41300 Klang, Selangor Darul Ehsan, Malaysia.  
☎ +603-3342 4379 / 80 / 3341 4381 | 📠 +603-3341 8084

🌐 [www.jsclamp.com](http://www.jsclamp.com)  
✉ [info@jsclamp.com](mailto:info@jsclamp.com) /  
[jsclamp2008@yahoo.com](mailto:jsclamp2008@yahoo.com)



Management  
System  
ISO 9001:2015

www.tuv.com  
ID 9105038625

