

# Electronic Instruction Manual Total Station



**R-315EX(NX)**

**R-325EX(NX)**

**R-335EX(NX)**

**R-322EX(NX)**

**R-323EX(NX)**

**R-326EX**

**R-300X Series BASIC**

**PENTAX Industrial Instruments Co., Ltd.**

2-5-2 Higashi-Oizumi / Nerima-ku, Tokyo 178-0063, Japan

Tel.: +81-3-5905-1222 / Fax: + 81-3-5905-1225

E-mail: [international@piic.pentax.co.jp](mailto:international@piic.pentax.co.jp)

Website: <http://www.pentax.co.jp/ppc>

[www.pentaxR300X.com](http://www.pentaxR300X.com)

**Before using this product**, be sure that you have thoroughly read and understood this instruction manual to ensure proper operation.  
After reading this manual, be sure to keep in a convenient place for easy reference.

Copyright © 2005 PENTAX Industrial Instruments Co., Ltd.

**All Rights Reserved**

PENTAX Industrial Instruments Co., Ltd. is a sole proprietor of the PTL software.

The PTL software and publication or parts thereof, may not be reproduced in any form, by any method, for any purpose.

PENTAX Industrial Instruments Co., Ltd. makes no warranty, expressed or implied, including but not limited to any implied warranties or merchantability or fitness for a particular purpose, regarding these materials and makes such materials available.

# PRECAUTIONS REGARDING SAFETY

## Safety precautions (Must be followed)

The following items are intended to prevent possible injury to the user or other people and/or damage to the instrument before it occurs. These safety precautions are important to the safe operation of this product and should be observed at all times.

## Distinctive displays

The following displays are used to distinguish precautions by the degree of injury or damage that may result if the precaution is ignored.



### **WARNING**

Items indicated by this display are precautions which if ignored would result in serious injury.



### **CAUTION**

Items indicated by this display are precautions which if ignored may result in injury or material.

- Here “injury” refers to injuries such as cuts, burns or electric shock the treatment of which will not likely require hospitalization or long-term attention.
- “Material damage” refers to damage to facilities, buildings, acquired data, etc.

Before using this product, be sure that you have thoroughly read and understood this instruction manual to ensure proper operation. After reading this manual, be sure to keep it in a convenient place for easy reference.

This instrument complies with the protection requirement for residential and commercial areas. If this instrument is used close to industrial areas or transmitters, the equipment can be influenced by electromagnetic fields.

Three R-300X Quick Reference Guide are provided in your carrying case.

They are

1. Basic Procedures,
2. Power Topo Lite Operating Procedures

# PRECAUTIONS REGARDING SAFETY



## WARNING

- ⚠ Do not stare into the laser beam directly as this may result in damage to your eyes. R-300X is a Class II Laser product. (The reflectorless type is a Class IIIa (3R) laser product.)
- ⚠ Do not look into the laser radiation aperture directly as this may result in damage to your eyes.
- ⚠ Never use the telescope to view intense light such as direct sunlight or sunlight reflected through a prism as this may result in loss of sight.
- ⚠ Do not disassemble, modify or repair this product as there is a risk of laser radiation.
- ⚠ Do not aim the laser beam at a person as it is harmful to the eyes and body. Receive the examination treatment by the doctor when the eyesight or body trouble is doubted by any chance.
  - Electro-Magnetic Compatibility (EMC):  
This instrument complies with the protection requirement for residential and commercial areas. If this instrument is used close to industrial areas or transmitters, the equipment can be influenced by electromagnetic fields.
  - Do not use this product in a coal mine, in a location where there is coal dust, or near flammable material as there is a risk of explosion.
  - Do not disassemble, modify or repair this product as there is a risk of fire, electric shock and burn injury. If you think the product requires repair, contact the retail outlet where you purchased it or an authorized repair site.
  - Only use the BC03 battery charger intended for this product as the battery charger. Use of another battery charger entails a risk of fire or burn injury from the battery bursting into flames due to possible differences in voltage or polarity.
  - Do not use a damaged electric cord plug or loose electric outlet when charging as there is a risk of fire or electric shock.
  - Do not charge the battery while covered by clothes or similar item as there is a risk of fire if the clothes ignite.
  - Do not use the battery or charger when wet as there is a risk of fire and burn injury due to short-circuit.
  - To prevent making short-circuit when removing the battery and charger from the case and storing them, apply electrically resistant tape to the poles of the battery. Storing the battery and charger as-is may result in fire or burn injury due to short-circuit.
  - Do not throw the battery into fire or expose it to heat as there is a risk of injury if it explodes.

# PRECAUTIONS REGARDING SAFETY



## CAUTION

- ⚠ For security, please do the opening inspection and inspection every a fixed period and adjustment.
- ⚠ When the laser beam enters eyes, an unexpected accident might be caused by the blink of eyes. Establish the laser product to avoid the height of eyes of a driving person and walker.
- ⚠ Establish an instrument so that laser beam does not hit a reflection thing as a mirror and a glass window. The reflection beam of the laser is also harmful to the human body.
- ⚠ Besides the time when you measure the distance, cut off the power supply or shade the beam of aperture with caps.
- ⚠ Keep the laser product in the place where the person who does not have the product knowledge such as children does not touch by mistake.
- ⚠ Destroy the power supply mechanism of the instrument so as not to emit the laser beam when throwing away it.
  - Do not remove the handgrip without good reason. If it does come off, be sure to attach it securely to the instrument with screws. If it is not fastened securely, the instrument may fall when you grasp the handgrip, leading to possible injury.
  - Do not short the poles of the battery or charger as there is a risk of injury or fire.
  - Do not touch any fluid which may leak from the battery as there is a risk of chemical burn injury or reaction.
  - Do not insert or remove the electric plug with wet hands as there is a risk of electric shock.
  - Do not use the case to stand on as it is slippery and unstable and may cause you to fall, resulting in possible injury.
  - Be sure the tripod itself and the instrument on the tripod are both installed securely as insecure installation may cause the tripod to fall over or the instrument to drop, resulting in possible injury.
  - Do not carry the tripod with the metal shoe pointing toward another person as the person may be injured if they strike him or her.



- The instrument contains a rechargeable battery and it is rechargeable.
- At the end of its useful life, it may be illegal to dispose of the battery.
- Check with your local solid waste officials for details for recycling.

# PRECAUTIONS REGARDING SAFETY

## Usage precautions

Surveying instruments are high-precision instruments. In order to assure that the Electronic Total Station R-300X series product which you have purchased will provide long-lasting maximum performance, the precautions in this manual must be followed. Be sure to follow these instructions and use this product properly at all times.

### [Solar observation]



#### WARNING

Never view the sun directly using the telescope as this may result in loss of sight. Never point the objective lens directly at the sun as this may damage internal components. When using the instrument for solar observation, be sure to attach the special solar filter (MU64) designed for this product to the objective lens.

### △ [Laser beam]

Do not stare into laser beam. R-300X is a class-II Laser product. (The reflectorless type is a Class IIIa (3R) laser product.)

### [EDM axis]

The R-300X series EDM is the red visible laser beam and the beam diameter is very small. The beam is emitted from the objective center and the base plate center hole. The EDM axis is designed to coincide with the telescope sight axis but both axes may not sometimes coincide slightly according to the intense temperature change and time lapse.

### [Target constant]

Confirm the Target Constant of the instrument before measurement.

If a different constant is to be used, use the correct constant of the target. The constant is stored in the instrument's memory when turned off.

### [Reflectorless and reflector sheet]

- Reflectorless:  
The measurement range and accuracy of Reflectorless are based on the condition that laser beam is emitted perpendicular to the white side of the Kodak Gray Card. The measurement range may be influenced by the shape of the target and its environment. There is a possibility that the range may vary when the target does not satisfy the conditions above at survey work.
- Pay attention to following in case of distance measurement by Reflectorless.  
In a situation resulting in low accuracy, perform the distance measurement by Reflector sheet or Prism. (R-315NX, R-325NX, R-335NX, R-322NX, R-323NX)
- There is a possibility that correct distance measurement may be impossible by dispersion or reduction of laser beam when the laser beam comes into the target from diagonal angle.

## PRECAUTIONS REGARDING SAFETY

- There is a possibility that the instrument cannot calculate correctly when receiving reflected laser beam from forth and back directions in case of measuring the target on the road.
  - There is a possibility that synthesized values are calculated and the distance may become longer or shorter than the actual one when the operator measure the target of slope or sphere or rugged shape.
  - There is a possibility that the instrument cannot calculate correctly by collecting the reflected laser beam from a man or a car that comes and goes in front of the target.
  - When using reflector sheet, set the reflector sheet to have its surface be approx. vertical to the aiming line. If it is positioned not to be approx. right angle, there is a possibility that correct distance measurement may be impossible by dispersion or reduction of laser beam.
- In the following environments, the distance might not be able to be measured.  
There is a reflection things (mirror, stainless board and white wall, etc.) in the direction of the target and under too strong sun light.

### [Battery & charger]

- Never use any battery charger other than the BC03 battery charger as this may result in damage to the instrument.
- If water should happen to splash on the instrument or the battery, wipe it off immediately and allow it to dry in a dry location. Do not put the instrument in the case until it is completely dry as this may result in damage to the instrument.
- Turn off the power when removing the battery from the instrument as removing the battery while the power is still on may result in damage to the instrument.
- The battery mark displayed on the instrument is only an estimate of remaining battery power and is not completely accurate. Replace the battery quickly when it is about to run down as the time a battery lasts on one charge differs depending on conditions of ambient temperature, and the measurement mode of the instrument.
- Confirm the battery level remaining before operating.

### [Auto focus]

The Auto focus mechanism is very precise but will not function under every condition. Focusing depends on brightness, contrast, the shape and size of the target. In such a case, press the AF button and focus on the target by operating the Power focus key or the AF ring.

### [LD POINT, laser pointer]

When you make a correct direction using the "LD POINT", aim the laser beam at the wall and mark the center and then confirm the discrepancy between the reticle center and the marked point beforehand.

## PRECAUTIONS REGARDING SAFETY

### **[Storage and operating environment]**

- To prevent making short-circuit when removing the battery and charger from the case and storing them, apply electrically resistant tape to the poles of the battery. Storing the battery and charger as is may result in fire or burn injury due to short-circuit.
- Avoid storing the instrument in places subject to extreme high, low or radically fluctuating temperature. (Ambient temperature range during use:  $-20^{\circ}\text{C}$  to  $+50^{\circ}\text{C}$ )
- Distance measurements may take longer when atmospheric conditions are poor such as when heat shimmer is present. When storing the instrument, always put it in its case and avoid storage in dusty location or location subject to vibration or extreme heat or humidity.
- Whenever there is a sharp temperature difference between the instrument's storage and usage locations allow the instrument to adjust to the ambient for an hour or more before use. Be sure to protect the instrument from the sun if the location is subject to intense direct sunlight.
- During surveys for which the survey precision or atmospheric measurement method has been defined measure the atmospheric temperature and pressure separately and enter those values rather than using the Automatic Atmospheric Correction function.
- The battery should be charged approximately once per month if the instrument is to be stored for an extended period of time. The instrument should also be removed from its case occasionally and aired out.
- In addition to these precautions, be sure to handle the instrument properly at all times following the descriptions given in the various sections of this manual to assure safe and proper measurements.

### **[Transporting and carrying the instrument]**

- Be careful to protect this instrument from shock of impact and excessive vibration which may result in damage during transportation and shipment.
- When transporting the instrument, always put it in the case and wrap shockabsorbing material around it and be sure it is handled as "FRAGILE".

### **[Checks and repairs]**

- Always check the instrument before beginning work and check that the instrument is maintaining the proper level of precision. Pentax bears absolutely no responsibility for damages due to survey results obtained from surveys conducted without an initial instrument check.
- Never disassemble the instrument, battery or charger even if you do detect an abnormality as there is a risk of fire or electric shock due to short-circuit. If you think the product requires repair, contact the retail outlet where you purchased it or an authorized repair site.



# CONTENTS

PRECAUTIONS REGARDING SAFETY	3
SAFETY PRECAUTIONS (MUST BE FOLLOWED)	3
USAGE PRECAUTIONS	6
<b>1. BEFORE USING THE INSTRUMENT</b>	<b>12</b>
1.1 NAMES OF PARTS	12
1.2 UNPACKING AND PACKING	14
1.3 STANDARD EQUIPMENT	14
1.4 ATTACHING AND CHARGING THE BATTERY	15
<b>2. DISPLAY AND KEYBOARD</b>	<b>18</b>
2.1 DISPLAY AND KEYBOARD	18
2.2 OPERATION KEY	18
2.3 FUNCTION KEY	19
2.4 ALPHANUMERIC INPUT	21
2.5 LD POINT, LASER POINTER	21
<b>3. PREPARATION FOR SURVEYING</b>	<b>22</b>
3.1 CENTERING AND LEVELING OF THE INSTRUMENT	22
3.2 LASER PLUMMET	23
3.3 OPTICAL PLUMMET (OPTION)	24
3.4 LEVELING WITH CIRCULAR VIAL	25
3.5 LEVELING WITH ELECTRONIC VIAL	25
3.6 EYEPIECE ADJUSTMENT	27
3.7 TARGET SIGHTING	27
3.8 ATTACHMENT AND DETACHMENT OF TRIBRACH	31
<b>4. TURNING THE POWER ON</b>	<b>32</b>
4.1 TURNING THE POWER ON AND OFF	32
4.2 ADJUSTING LCD CONTRAST	33
4.3 ADJUSTING ILLUMINATION BRIGHTNESS	33
4.4 ADJUSTING RETICLE ILLUMINATION	34
<b>5. ANGLE MEASUREMENT</b>	<b>35</b>
5.1 MEASURING AN ANGLE	35
5.2 RESETTING THE HORIZONTAL ANGLE TO 0	35
5.3 HOLDING THE HORIZONTAL ANGLE	36
5.4 INPUTTING AN ARBITRARY HORIZONTAL ANGLE	36
5.5 DISPLAYING THE % SLOPE OF THE VERTICAL ANGLE	47
5.6 CHANGING THE HORIZONTAL ANGLE FROM CLOCKWISE TO COUNTERCLOCKWISE	38

<b>6. DISTANCE MEASUREMENT</b>	39
6.1 TARGET SETTING	39
6.2 DISTANCE MEASUREMENT	41
6.3 QUICK MODE	42
<b>7. CORRECTION MODE</b>	43
7.1 CHANGING THE TARGET CONSTANT	43
7.2 CHANGING THE TEMPERATURE	44
7.3 CHANGING THE ATMOSPHERIC PRESSURE	45
7.4 CHANGING THE PPM VALUE	46
<b>8. INITIAL SETTING</b>	48
8.1 OVERVIEW	48
8.2 ENTERING THE MODE FOR INITIAL SETTING 1	48
8.3 ENTERING THE MODE FOR INITIAL SETTING 2	49
8.4 ENTERING THE MODE FOR INITIAL SETTING 4	49
8.5 ENTERING THE MODE FOR INITIAL SETTING 5	49
8.6 SETTING OF [DATE AND TIME]	50
8.7 EXAMPLE OF CHANGING AN INITIAL SETTING CONTENT (SELECTION OF ATMOSPHERIC CORRECTION)	50
8.8 INITIAL SETTING 1	50
8.9 INITIAL SETTING 2	51
8.10 INITIAL SETTING 4	55
8.11 INITIAL SETTING 5	55
8.12 INITIAL SETTING OF DATE AND TIME	56
<b>9. ACCESSING THE FUNCTIONS</b>	57
9.1 ACCESSING BY HELP KEY	57
9.2 ACCESSING BY 007	57
<b>10. CHECKS AND ADJUSTMENTS</b>	59
10.1 ELECTRONIC VIAL	59
10.2 CIRCULAR VIAL	60
10.3 VERTICAL RETICLE	61
10.4 PERPENDICULARITY OF LINE OF SIGHT TO HORIZONTAL AXIS	62
10.5 VERTICAL 0 POINT ERROR	63
10.6 LASER PLUMMET	63
10.7 OPTICAL PLUMMET	64
10.8 OFFSET CONSTANT	65
10.9 BEAM AXIS AND LINE OF SIGHT	65
10.10 THE EDM BEAM AXIS	66
<b>11. SPECIFICATIONS</b>	67
<b>12. DATA COLLECTOR</b>	69

<b>13. APPENDIX</b>	70
13.1 ERROR MESSAGES	70
13.2 ATMOSPHERIC CORRECTION	71
13.3 HPA AND MMHG CONVERSION TABLE	72
13.4 ERROR WHEN NO ATMOSPHERIC CORRECTION IS MADE	72
13.5 ATMOSPHERIC REFRACTION AND EARTH CURVATURE CORRECTION	73
13.6 DISTANCE RANGE	74
<b>14. NOTICE TO THE USER OF THIS PRODUCT</b>	75

# 1. BEFORE USING THE INSTRUMENT

## 1.1 Names of parts

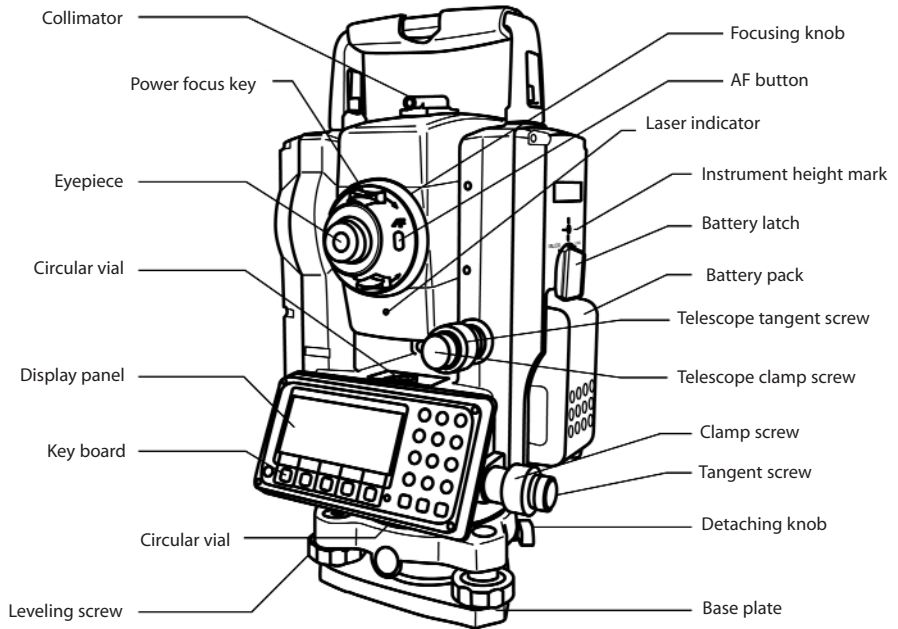

**R-325EX(NX)/ R-322EX(NX)/ R-323EX(NX): Detachable type**

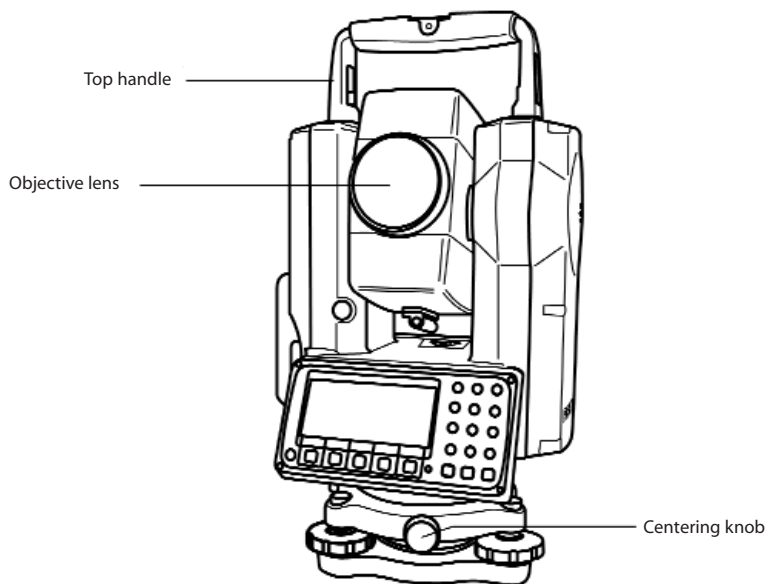

**R-335EX (NX): Shift type**

- Dual display panel is an optional accessory.

---

## 1.2 Unpacking and packing

### [Unpacking the Instrument from the case]

- ① Set the case down gently with the lid facing upwards.
- ② Open the latches while pressing down on the lock (safety mechanism) and open the lid of the case.
- ③ Remove the instrument from the case.

### [Packing the instrument in the case]

- ① Make sure the telescope is fairly level and lightly tighten the telescope clamp screw.
- ② Line up the housing marks (round yellow marks on the instrument) and tighten the upper and lower clamp screws.
- ③ With the housing marks facing upward, set the instrument gently in the case without forcing it.
- ④ Close the lid to the case and secure the latches.

---

## 1.3 Standard equipment

- ① Instrument
- ② Carrying case
- ③ BP02 battery
- ④ BC03/AC01 charger
- ⑤ Plumb bob
- ⑥ Hexagonal wrench
- ⑦ Rain cover
- ⑧ Quick Reference Guide (Basic, PTL procedures)
- ⑨ CD-R (Basic operation & Special Functions manual)

## 1.4 Attaching and charging the battery

### [Removing the battery]

- ① Turn the lock lever anticlockwise and remove the battery.
  - ② Lift up the battery pack and remove it from the instrument.
- Be absolutely sure to turn the power off when removing the battery as removing the battery while the power is still on may result in damage to the instrument.

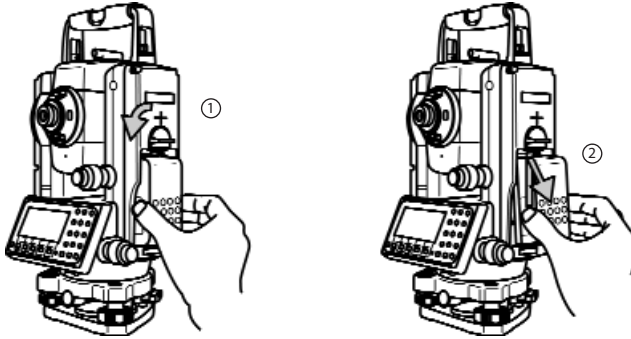



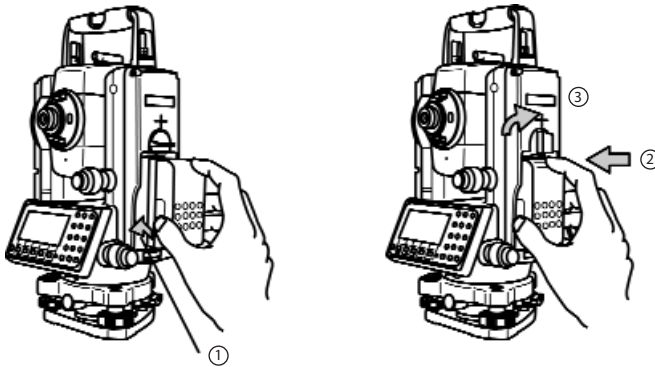

### [Attaching the battery]

- ① Align the guide grooves on the battery pack with the guide grooves on the instrument and push the top of the battery pack into place.
- ② Turn the lock lever clockwise to fix.



### [Remaining battery charge]

When the instrument's power is turned on, a battery mark "  " will be displayed on the right of the display screen. This mark can be used to check the charge status of the battery.

-  Plenty of charge left
-  Get the spare battery ready
-  Replace with the spare battery

Low battery: Please change. Replace with the spare battery or charge.

### [Charging the battery]

- The battery BP02 is not charged at our factory shipment so charge it.
- For BP02 charge, use the special BC03 charger.

Power supply cord

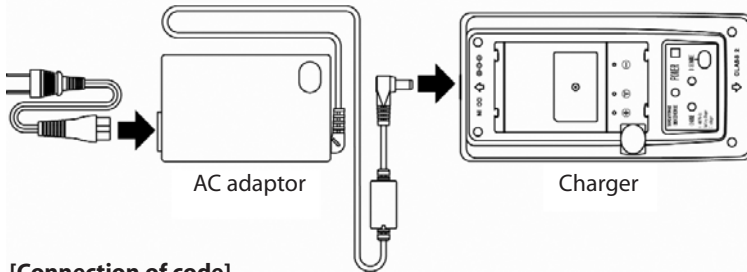

### [Connection of code]

- ① Insert the output plug of the power supply code in Jack of the AC adaptor.
- ② Insert the output plug of the AC adaptor in Jack of the charger.
- ③ Insert the power supply plug of the power supply code in the outlet of AC power supply.

### [Installation of battery]

- ① Draw the battery to the lock lever side and put it on the battery pocket. The battery is firmly installed on the battery pocket.
- ② Press down the battery and then slide it to the opposite direction of the lock lever.
- ③ The lock lever goes up, and the battery is fixed.
- ④ Under such a condition, if "Connection of the code" is done, the charge with the battery is begun.

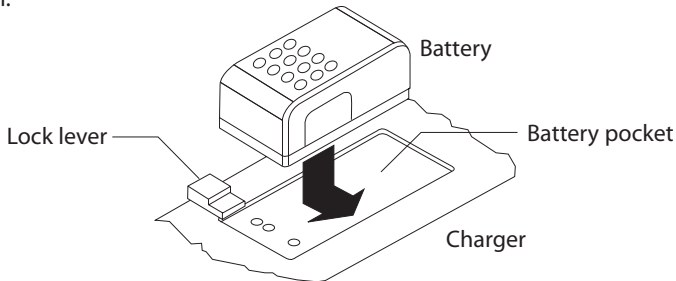

### [Detaching the battery]

- ① Press the lock lever and slide the battery to the lock lever direction.
- ② Detach the battery packing from the battery pocket.

### [Display panel]

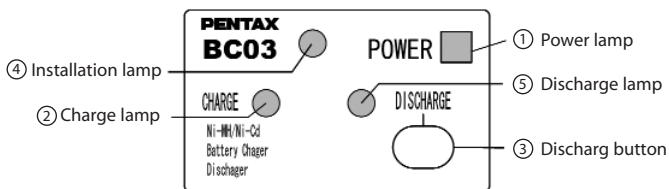



- ① Power supply lamp (red) :Turns on when the power supply is turned on.
- ② Charge lamp (green): Turns on while charging and turns off when the charge is completed.
- ③ Discharge lamp (yellow): Turns on when you push the discharge button.  
Turns off when the discharge is completed.
- ④ Installation lamp (red): Blinks or turns on when the battery packing is attached normally.  
Blinks when charge or discharge and turns on when charge is completed.  
(The charge lamp in the lower does not blink and does not turns on)
- ⑤ Discharge button: Discharge lamp lights when you push this button, and the discharge of battery begins.

### **[How to charge]**

- ① It begins charging automatically when you set the battery packing in the charger which beams the power supply lamp.
- ② Leave just as it is until the charge is completed.
- ③ When the charge is completed, the charge lamp is turned off.
- ④ Detach the battery packing from the charger when the charge is completed.

### **[Refreshing the battery]**

The use time shortens gradually by the phenomenon of “Effect of the memory” when the NiMH battery leaves capacity and repeats the charge. The voltage recovers after refreshing and the use time returns normally in such a battery. Please refresh one degree every five times of the charge.

### **[Refreshing]**

Set the battery in the charger as well as the case of the charge. Push the electrical discharge button. The electrical discharge lamp lights and the electrical discharge begins. The electrical discharge lamp is turned off when the electrical discharge ends, the charge lamp lights, and the charge starts automatically. Leave just as it is until the charge is completed. When the charge is completed, the charge lamp is turned off. Detach the battery from the charger.

### **[Time of refreshing and charge]**

Battery BP02 is discharged from the state of a full charge at about 960 minutes and the charge is completed from the electrical discharge at about 130 minutes. However, the electrical discharge time is proportional to the remainder capacity of the battery. Moreover, the time required for refreshing might be different from the above-mentioned time according to a surrounding temperature and the state of the battery.

## 2. DISPLAY AND KEYBOARD

### 2.1 Display and keyboard

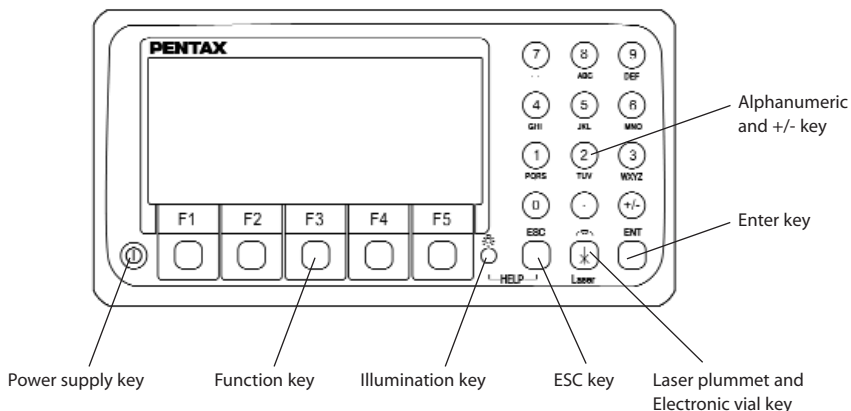

### 2.2 Operation key

Key	Description
[POWER]	ON/OFF of power supply
[ESC]	Returns to previous screen or cancels an operation.
[ILLU]	Turns the illumination of the LCD display and telescope reticle on and off.
[ENT]	Accepts the selected (highlighted) choice or the displayed screen value.
[LASER]	Displays the laser plummet *1, electronic vial function, and the LD point screen when you push the laser plummet/electronic vial key. (Refer to "2-5 Laser Pointer", "3-2 Laser plummet", and "3-5 Leveling with Electronic vial").  *1: Only the product with the laser plummet function
[Alphanumeric]	At the numerical value screen, the numerical value and the sign "." displayed are input. The English characters printed right under numeric of each key are input.
[HELP]	Pressing [ILLU]+[ESC] key causes a help menu to appear in A MODE or B MODE or causes a help message to appear.

## 2.3 Function Key

Display	F. Key	Description
<b>MODE A</b>		
[MEAS]	F1	Pressing this key one time measures the distance in normal mode another measurement type can be selected by Initial Setting 2. Pressing this key twice measures the distance in coarse mode another measurement type can be selected by Initial Setting 2.
[TARGET]	F2	Select the target type by following order. SHEET/ REFLECTORLESS /PRISM (Reflectorless type instrument) SHEET/PRISM (Prism type instrument)
[0 SET]	F3	Resets the horizontal angle to 0° 0' 0" by pressing twice.
[DISP]	F4	Switches the display composition in the order "H.angle/H.dst./V.dst.," "H.angle/V.angle/S.dst." and "H.angle/V.angle/H.dst./S.dst./V.dst."
[MODE]	F5	Switches the screen between MODE A and MODE B.
<b>MODE B</b>		
[S.FUNC]	F1	PowerTopoLite
[ANG SET]	F2	Brings up the angle setting screen for setting angle-related parameters (H.ANGLE/%GRADE, H.ANGLE INPUT and R/L REVERSE).
[HOLD]	F3	Pressing this key twice retains (holds) the horizontal angle shown on the display.
[CORR]	F4	Brings up the screen for changing the target constant, temperature. Pressure setting.
[MODE]	F5	Switches the screen between MODE A and MODE B.

## Other functions

[←]	F1	Moves the cursor to the left.
[→]	F2	Moves the cursor to the right.
[▲]	F1	Goes back five items on the screen.
[▼]	F2	Goes forward five items on the screen.
[RETICLE]	F3	Changing the reticle illumination when pressing illumination key.
[↑]	F3	Moves the cursor up.
[LCD]	F4	Changing the LCD contrast when pressing illumination key.
[↓]	F4	Moves the cursor down.
[ILLU]	F5	Changing the LCD illumination when pressing illumination key.
[CLEAR]	F5	Clear the figure.
[SELECT]	F5	Open the selection window.

### [How to move the menu number]

#### Example:

The cursor is located at Menu 1.

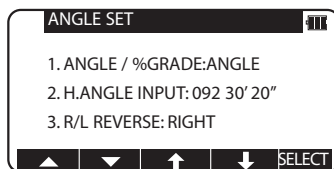

Press the numeric key 0 and 2 to move to Menu 2 or press [F4] [↑].

