

DISTRICT IX P.I.A.A.

# WRESTLING TOURNAMENT

March 1 & 2, Waldo S. Tippin Gymnasium, Clarion University

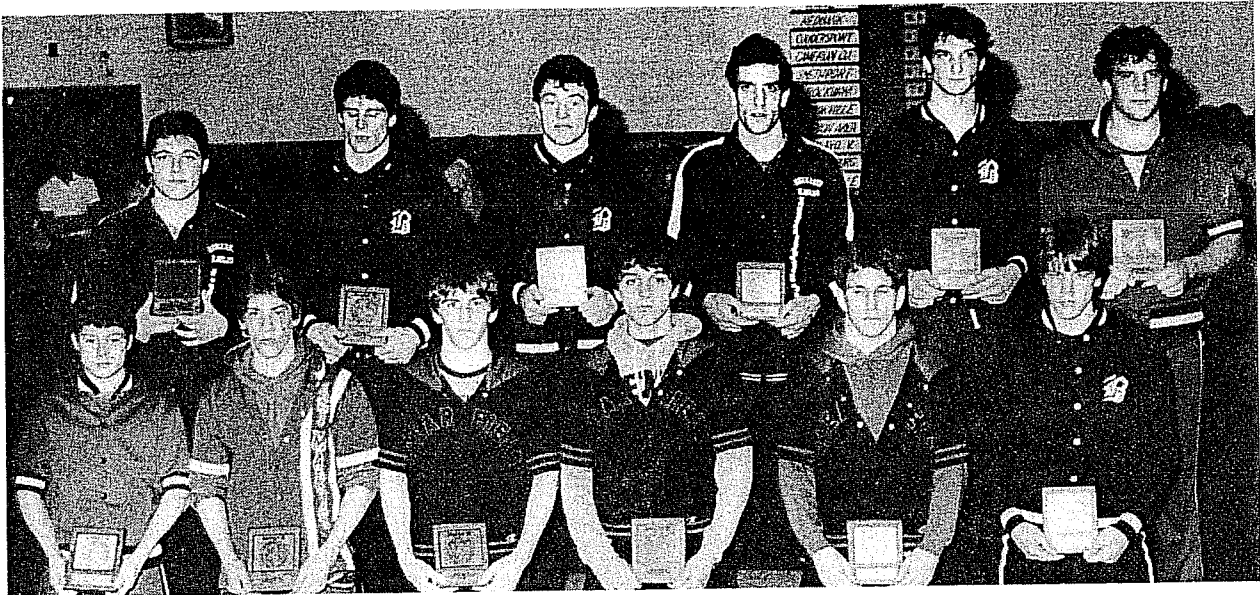

1984 DISTRICT IX CLASS AAA CHAMPIONS: Front row (l-r); 98-Jim Royer (D), 105-Tim Wittman (SM), 112-Scott Collins (CI), 119-Shay French (CI), 126-Scott Luzier (CI) and 132-John Straub (Bed.). Back row (l-r); 138-Joe Lutetri (So), 145-Gary Diehl (Bed.), 155-John Topper (Bed.), 167-Ron Darr (So), 185-Justin Buterbaugh (Bed.) and Hwt-Frank Zimmerman (D).



1984 DISTRICT IX CLASS AA CHAMPIONS: Front row (l-r); 98-Seth Bloomquist (K), 105-Terry Crawford (RBV), 112-Todd Hulings (K), 119-Rick Ord (Br), 126-Steve Valenti (S) and 132-Don Horning (CC). Back row (l-r); 138-Paul Nearing (R), 145-Roger Dunn (Co), 155-T. J. Reap (S), 167-Rob Burford (RBV), 185-Dean Jacks (CI) and Hwt-Frank Dean (OV).

## BOUT AND MAT ASSIGNMENTS

**FRIDAY AFTERNOON** Class AA only, 1:30 p.m.  
Three mats—98 lbs.-hwt.  
Wrestlers will wrestle in order drawn at seeding meeting.

**FRIDAY EVENING** Class AAA and AA, 6:00 p.m.  
Mat 1 Class AA:  
98 lbs. to 132 lbs.  
Mat 2 Class AA:  
138 lbs. to Heavyweight  
Mat 3 Class AAA:  
All Weights

**SATURDAY** 11:00 a.m. AA semifinals and Con.  
Mat 1 Class AA: 98-132 lbs.  
Mat 2 Class AA; 138-Hwt.  
Mat 3 Class AA: Con. all weights

1:30 p.m. Mat 1 Class AA Con. Semis  
Mat 2 Class AAA: 98 to Hwt.  
Mat 3 Class AAA: 98 to Hwt.

5:00 p.m. Mat 1 Class AA Con. finals  
Mat 2 Class AAA Con. finals  
Mat 3 Class AAA Con. finals

6:30 p.m. AA and AAA finals  
Mat 1 Class AA all weights  
Mat 2 Class AAA all weights

1 Coach of the Year - Barry Johnson

- 1 Randy Weisner, Ecc (10) 15-0-0
- Bye
- Scott Reynolds, Sm., (12) 6-11
- Steve Cristini, Rdg. (9) 10-13-1
- 5 Daryl Sassaman, C.C. (10) 13-5
- Chris Lilly, P.A. (11) 8-6
- Bye
- 4 Mike Martin, Coud. (12) 13-5-2
- 3 Jeff DuFour, Curw. (10) 17-5
- Bye
- 6 Eugene Brown, Kn., (10) 15-6
- 7 John Carlson, Bkw. (9) 10-11-0
- Phil Stilson, O.V. (9) 4-12
- Rick Grube, Brk. (9) 6-11
- 2 Rick Kirkpatrick, RBV (9) 17-3

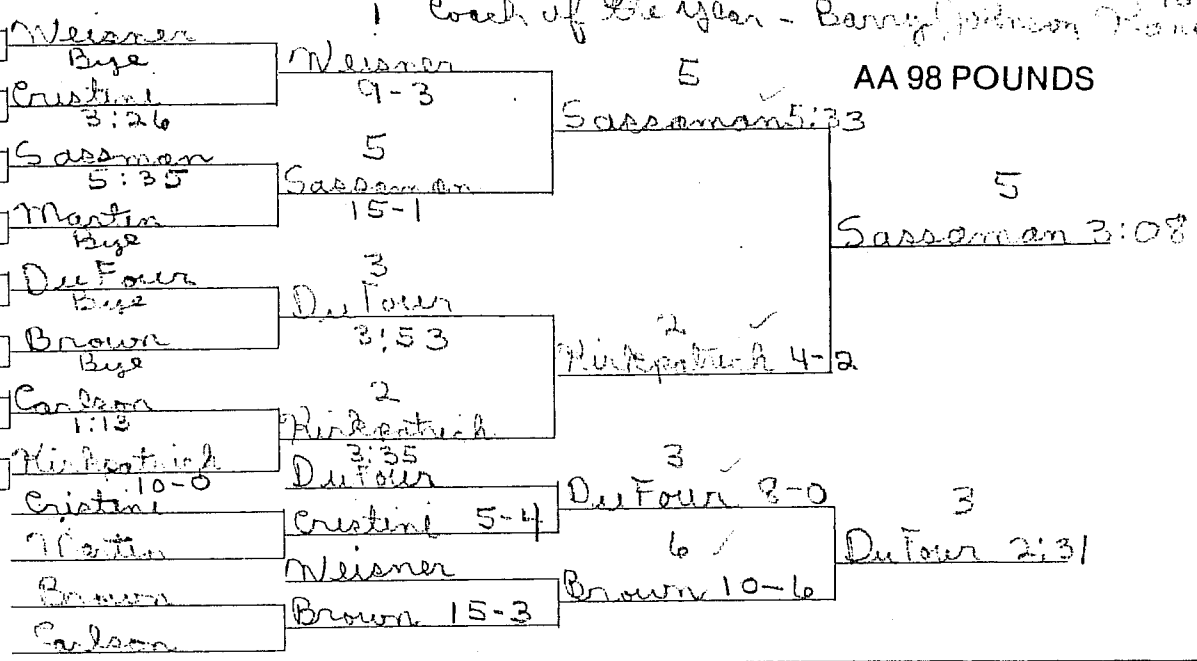

- 1 Scott Rimer, Jbrg. (11) 17-4-1
- Bill Howard, O.V. 5-15
- Bye
- John Sauve, Coud., (9) 11-9-1
- 5 Steve Davido, Rdg. (12) 14-7
- Greg Stanko, Kn., (10) 3-8
- Bye
- 4 Pete Varischetti, Bkw. (9) 15-7
- 3 Troy Burkett, Brk. (12) 12-5
- Randy Sipes, Curw. (10) 7-12
- Chris Reuscher, ECC (11) 0-12
- Troy Shall, P.A. (11) 12-5
- Mike Stuart, C.C. (9) 11-10
- Bye
- 2 Steve Gunter, RBV (12) 15-5

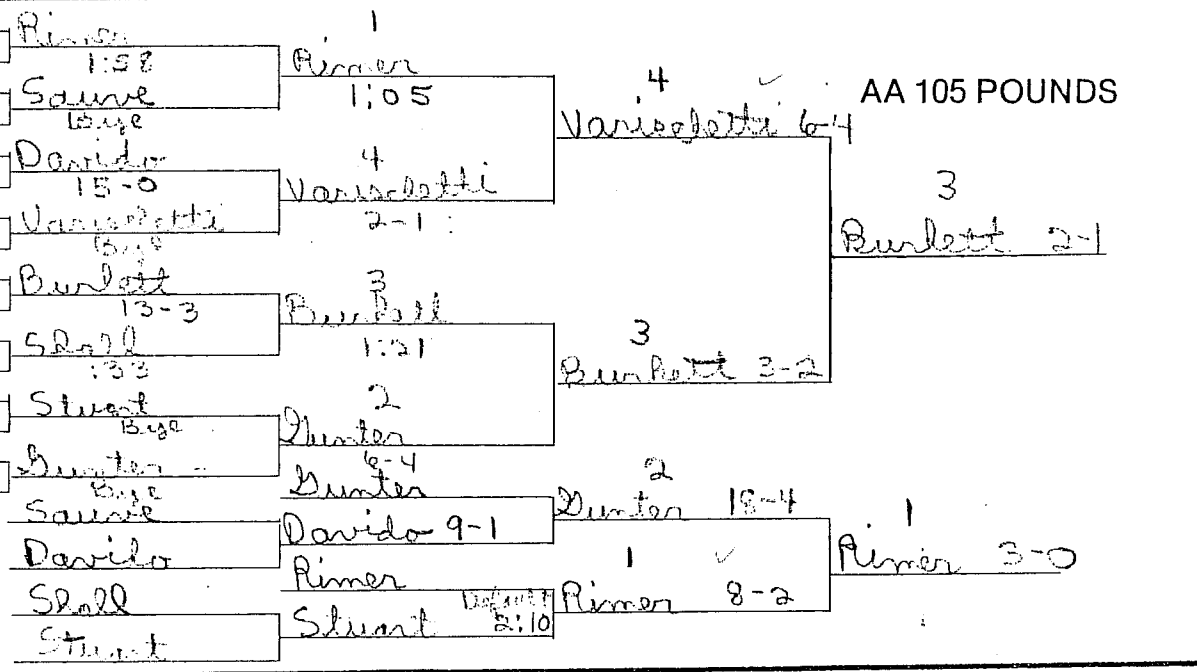

- 1 D. Buchsenschutz, P.A. (11) 12-2
- Bye
- Tim Thrush, Brkv. (12) 5-13
- 8 Doug Young, Rldg. (10) 9-11-1
- 5 Tim Buerk, E.C.C. (12) 13-3
- Bye
- Phil Cruz, Coud., (11) 12-8
- 4 Terry Crawford, RBV (10) 16-4
- 3 Craig Turner, Curw. (10) 13-7-1
- Bye
- Steve Jefferts, Kn., (10) 5-8
- 6 Scott Storm, Jbrg. (12) 16-6
- 7 Don Burdick, Sm., (11) 14-5
- Bye
- Denny Keech, O.V. (11) 9-9-12
- 2 Butch Gennocro, C.C. (12) 13-5-2

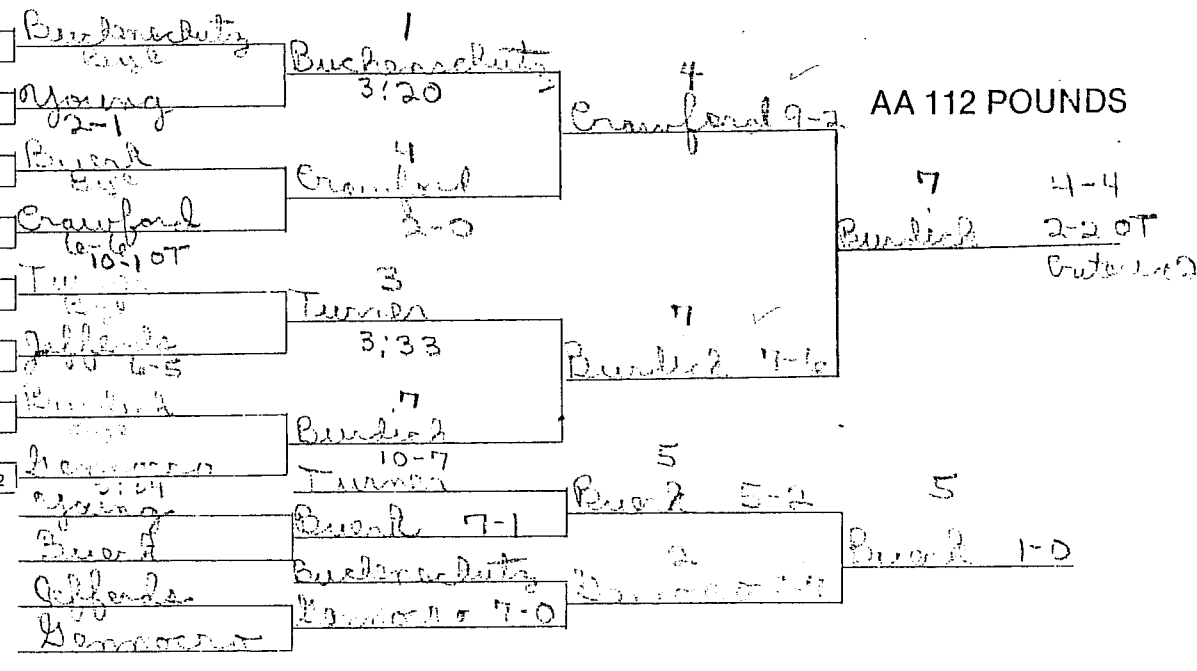

- 1 D. Blankenship, Kn., (11) 24-1
- Bye
- Da. Rensel, Cl., (12) 3-11
- Bye
- Tim. Blausen, Rdg., (9) 2-14
- Bye
- Butch Barber, Jbrg., (9) 9-5-T
- 5 John Wineburg, Brkw., (11) 14-6
- Bye
- Chris Burden, E.C.C. (12) 2-13-1
- 4 Sean Lathrop, Sm., (12) 8-4-1
- 3 J. Buchsenschutz, P.A. (12) 15-2
- Bye
- Bye
- 6 Scott Reinard, Bkw. (10) 14-4
- 7 Chris Lewis, Curw., (10) 9-11-1
- Steve Canfield, O.V. (9) 2-12
- Steve Williams, RBV, (12) 12-7
- 2 Phil Dewey, Coud. (12) 18-2

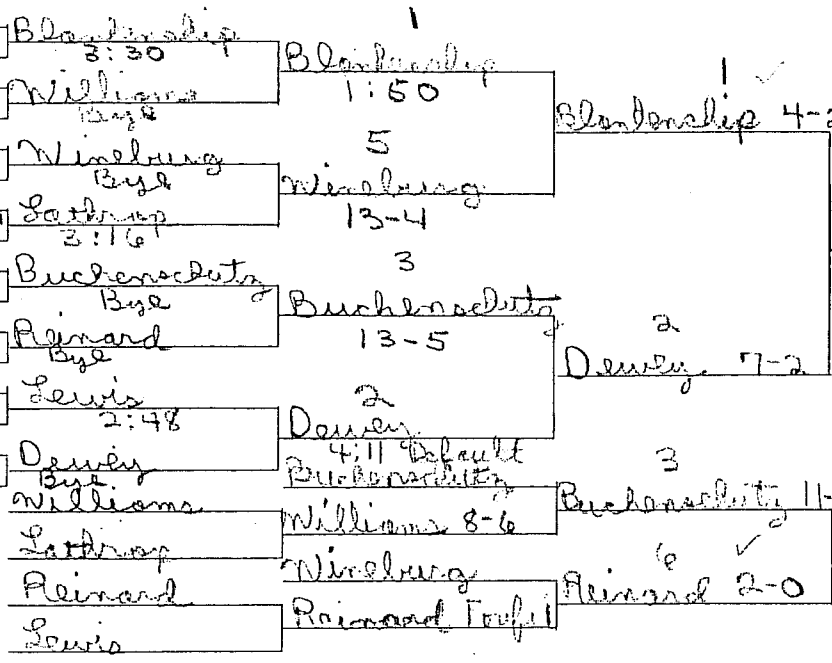

AA 119 POUNDS

1

Blankenship 4-2

Blankenship 1:22

2

Dewey 7-2

3

Buchsenschutz 11-3

3

Buchsenschutz 2:46

6

Reinard 2-0

- 1 Steve Valenti, Sm., (12) 16-1
- Ed DeCecchis, Jbrg. (10) 6-12
- Bill Lees, Cl., (10) 6-9
- 8 J. Rosenhoover, Rdg. (11) 9-11
- 5 John Colwell, RBV, (12) 14-6
- Brian Wetzel, Curw. (9) 3-12-2
- Bye
- 4 Mike Pisarchick, Bkw. (9) 18-4-1
- 3 Shawn Galbreath, Brkw. (10) 12-4
- Bye
- Mike Smith, C.C. (11) 2-11
- 6 Allan Hackett, Coud. (12) 12-9
- 7 Doug Smith, P.A. (10) 9-2
- Bye
- Scott Taylor, ECC (11) 6-8
- 2 Jack Bell, Kn., (11) 20-1

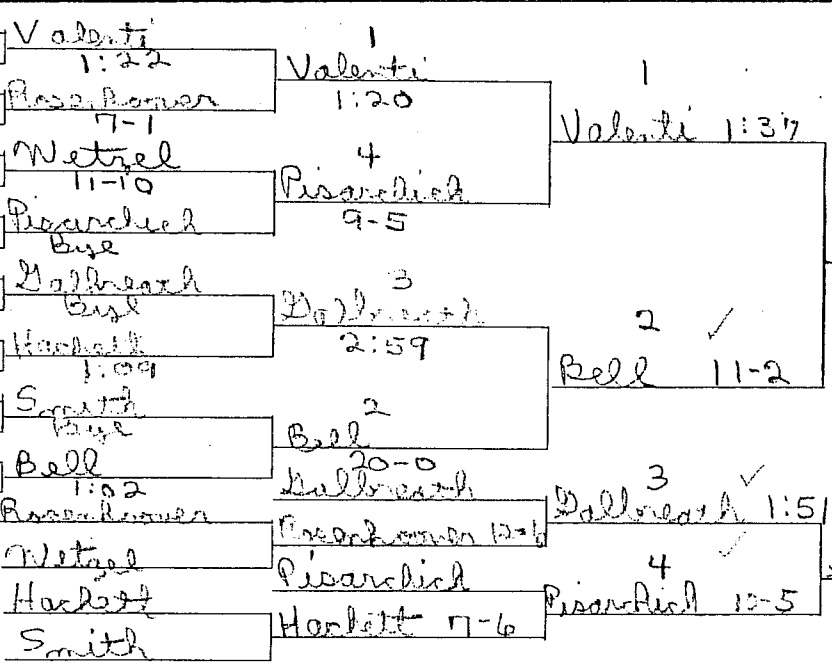

AA 126 POUNDS

1

Valenti 1:37

2

Bell 5-1

2

Bell 11-2

3

Galbreath 1:51

3

Galbreath 6-2

4

Pisarchick 10-5

- 1 Nick Gulsto, CC (12) 20-5
- Bye
- Steve Keller, Curw. (10) 0-4
- 8 Rich Shirey, RBV, (11) 4-7
- 5 Bob Eustace, Coud. (12) 9-7
- Jerry Tessena, Sm., (10) 0-1
- Bye
- 4 Don Hoffman, Rdg. (11) 17-5
- 3 Mark Murgash, Bkw. (11) 15-5
- Bye
- Pete Klaiber, ECC (12) 1-13
- 6 Brian Mauro, Cl., (9) 5-4
- 7 Sam Downing, Brv. (10) 5-13
- Kevin Watson, O.V. (12) 5-12
- Jim Zimmerman, Jbrg. (10) 0-1
- 2 Roger Blankenship, Kn. (10) 16-3

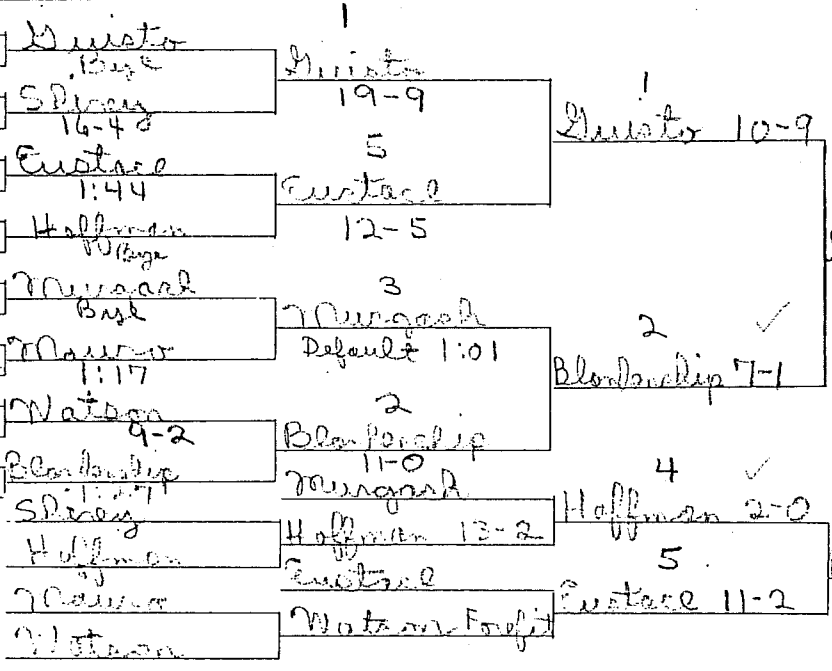

AA 132 POUNDS

1

Gulsto 10-9

2

Blankenship 5-0

2

Blankenship 7-1

4

Hoffman 2-0

5

Eustace 7-6

5

Eustace 11-2

- 1 Dana Hook, RBV (12) 18-0-1
- Bob Burleson, P.A. (11) 7-4-1
- Stan Marshall, ECC. (9) 0-15
- 8 Curt Cristini, Rdg. (10) 5-5
- 5 Dave Inzana, Bkw. (12) 18-4
- Bill Weizel, Curw. (10) 5-11
- Bye
- 4 Donald Allegretto, Jbrg. (11) 17-6
- 3 Glenn Drake, O.V. (12) 21-2
- Bye
- Tim Powell, Bkw. (11) 0-2
- 6 Frank Blizak, Kn., (11) 13-10
- 7 Keith Girvan, Cl., (10) 11-6
- Craig Schloder, C.C. (10) 2-11
- Ron Myers, Sm., (11) 4-5-1
- 2 Dan Cowburn, Coud. (11) 18-3

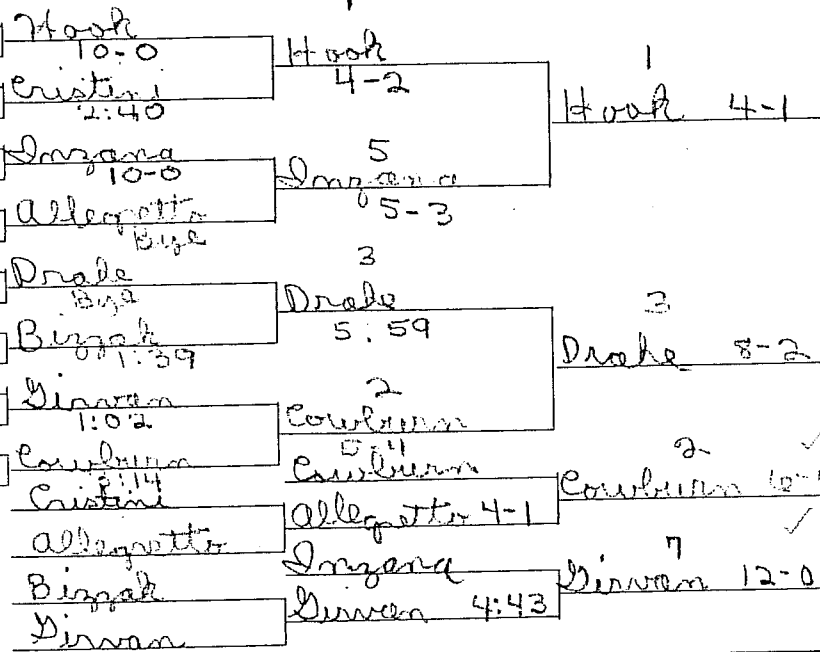

AA 138 POUNDS

- 1 Jeff Stenta, Rdg. (12) 21-2
- Ron McClure, Curw. (12) 5-6
- Sean Pyle, Brkv. (11) 6-10
- 8 Mark Seabolt, C.C. (12) 4-4
- 5 Brent Hetrick, RBV (12) 14-7
- Dale Nogar, Sm. (12) 3-15
- Bye
- 4 Dan Rook, Kn. (11) 17-7-1
- 3 Jeff Peterson, Jbrg. (11) 16-5-1
- Bye
- Matt Hockins, Cl., (12) 1-1
- 6 Jim Carey, Coud. (11) 11-5
- 7 Ken Lindsey, P.A. (11) 9-4
- Andy Miller, Bkw. (10) 8-14-1
- Colin Foster, ECC (11) 0-9
- 2 Kris Fuller, O.V. (12) 22-2

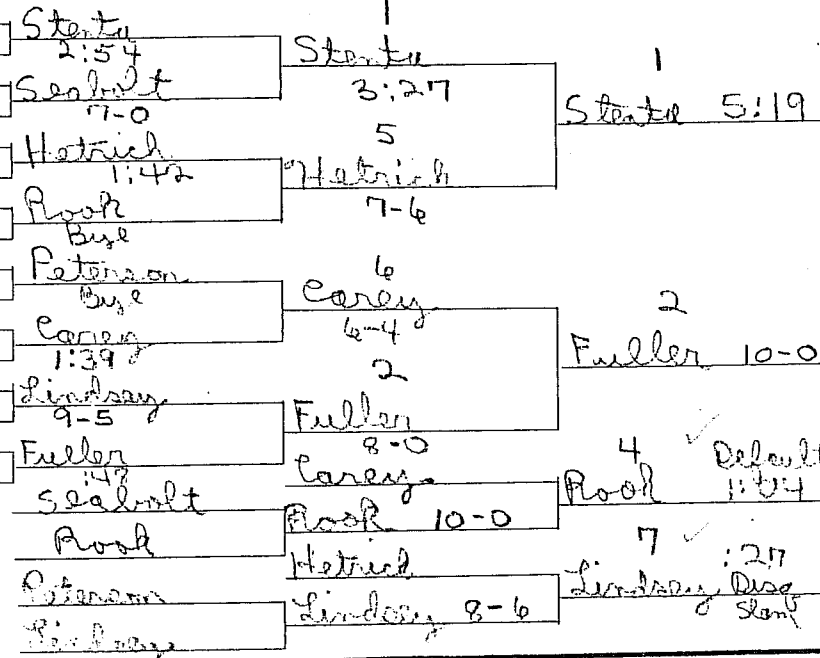

AA 145 POUNDS

- 1 Ron Nortum, Jbrg. (12) 20-3
- Gary Cristini, Bkw. (10) 2-10
- Ron Bhe, Sm., (11) 1-7
- 8 R. J. Sherwood, P.A. (10) 11-6
- 5 Bob Lamonl, C.C. (10) 14-6
- Tim Troup, RBV, (12) 2-3
- Bye
- 4 Kevin Harriger, Bkw. (12) 12-5-1
- 3 Mike Bloom, Curw. (12) 15-7
- Joe Geer, Kn., (10) 2-4
- Mike Slager, ECC (11) 0-9
- 6 Lee Weber, Rdg. (11) 5-5
- 7 Sean McKeone, Coud. (11) 4-1
- Burke Smith, O.V. (11) 2-7
- Bye
- 2 Dave Neff, Cl., (12) 14-1-1

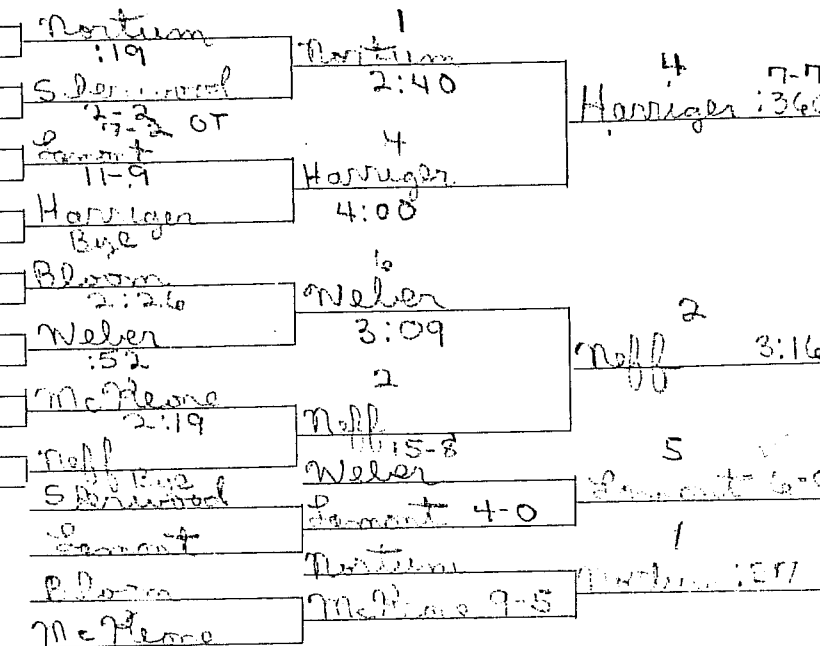

AA 155 POUNDS

1 T. J. Reap, Sm., (11) 20-0-0

Mike Hart, C.C. (11) 5-9

Joe Ferranto, Kn., (9) 0-0

8 Tim Bickel, O.V. (12) 9-5

5 Craig Gibble, Coud., (11) 11-3

Bye

Scott Park, Bkv. (10) 0-10-1

4 Ron Rapp, Cl., (11) 11-5-2

3 Glenn Tittler, Rdg. (12) 15-4-2

David Domico, Curw. (10) 5-9

Bye

6 Dale Budd, P.A. (9) 9-2

7 Davald Sallack, Jbrg. (9) 6-5

Jeff Hathaway, RBV (10) 8-8-1

Bye

Chris Miller, Bkw. (12) 21-1

Reap  
7-1

1  
Reap  
2:11

Bickel  
2:49

Gibble  
Bye

Rapp  
15-2

Tittler  
10-8

Budd  
Bye

Sallack  
10-7

Hathaway  
Bye

Miller  
Bye

Bickel  
Gibble 15-4

Tittler  
Sallack

4  
Rapp  
1:54

6  
Budd  
8-5

2  
Miller  
14-0

5  
Budd  
11-8

5  
Gibble  
15-4

UN  
Rapp  
Sallack 8-7

UN  
Sallack  
4-3

1 ✓  
Reap 6-0

2  
Miller 6-0

5  
Gibble 11-8

UN ✓  
Sallack 4-3

AA 167 POUNDS

2  
Miller 9-3

UN

Sallack 1:50

1 Ed Parker, Rdg. (12) 19-2

Bye

Bye

8 Jack Kifer, Jbrg. (11) 7-13

5 Bryan Shirey, RBV (12) 11-6-1

Scott Hungville, Sm., (11) 5-5-1

Denny Gross, C.C. (12) 4-8

4 Brian Dimmick, Curw. (11) 11-6-2

3 Rich Geer, Kn., (12) 21-4

Bye

Bye

6 Todd Wheaton, O.V. (11) 14-7

7 Terry Spader, P.A. (12) 7-6

Bill Bullers, Bkv. (11) 1-8

Bye

2 Jim Campbell, Cl., (10) 11-0-1

Parker  
Bye

Bye

Kifer  
Bye

Shirey  
2:37

Dimmick  
10-1

Geer  
Bye

Wheaton  
Bye

Spader  
8-0

Campbell  
Bye

Kifer  
Dimmick 5-0

Wheaton  
Spader

1  
Parker  
3:30

5  
Shirey  
10-7

3  
Geer  
12-7

2  
Campbell  
3:36

3  
Deer  
9-1

6 ✓  
Wheaton  
7-5

1  
Parker  
12:18

2 ✓  
Campbell  
18-10

3  
Deer  
9-1

6 ✓  
Wheaton  
7-5

3  
Deer  
9-1

6 ✓  
Wheaton  
7-5

AA 185 POUNDS

1  
Parker 6-5

3  
Deer 6-1

1 Darren Burford, RBV (12) 16-2

Jim McIsac, C.C. (12) 0-0

Bye

8 Don Dickey, Jbrg. (10) 11-11

5 Jim Demchak, Curw. (12) 17-4-1

Dan McCracken, Sm., (11) 3-15

Bye

4 Bill Lyle, Rdg. (12) 15-5-2

3 John Lorenzo, Kn. (12) 22-4

Roger Veilleaux, P.A. (11) 7-2-1

Bye

6 Joe Ayers, Coud. (11) 14-4

7 Andy McWilliams, Bkv. (11) 8-10

Bye

Mark Wilson, O.V. (12) 5-10

2 Kelly Taylor, Bkw. (12) 18-3-1

Burford  
1:52

Dickey  
Bye

Demchak  
1:10

Lyle  
Bye

Lorenzo  
1:50

Ayers  
Bye

McWilliams  
Bye

Wilson  
Taylor  
2:29

Dickey  
Lyle 4:48

Lyle  
Demchak

Ayers  
McWilliams

1  
Burford  
2:40

5  
Demchak  
9-6

3  
Lorenzo  
3:12

2  
Taylor  
2:29

4  
Lyle  
4:48

5  
Demchak  
12-3

1  
Burford  
1:26

1  
Burford  
3-2

3  
Lorenzo  
7-0

4  
Lyle  
5-20T

5  
Demchak  
12-3

1  
Burford  
2-0

4  
Lyle  
5-20T

5  
Demchak  
12-3

AA HEAVYWEIGHT

1  
Burford 2-0

4  
Lyle 5-5

5  
Lyle 5-30T

Coach of the Year - Gary Boston Clearfield  
 Todd Williams, Clearfield (11) 19-4  
 Scott Collins 119 LBS  
 Clearfield

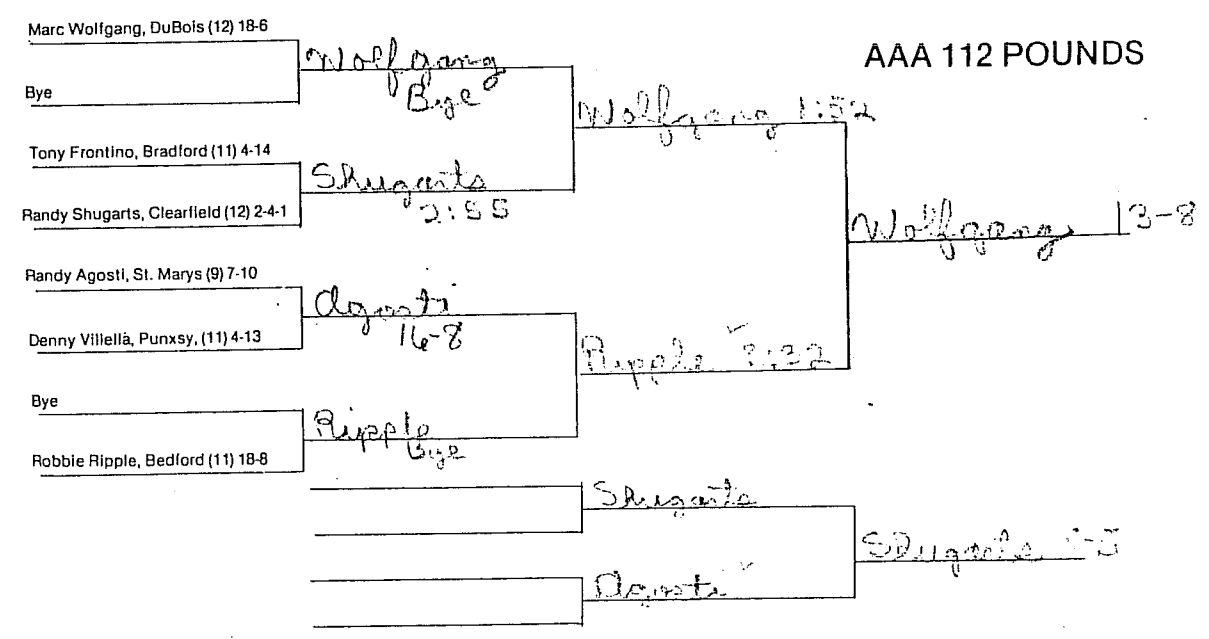
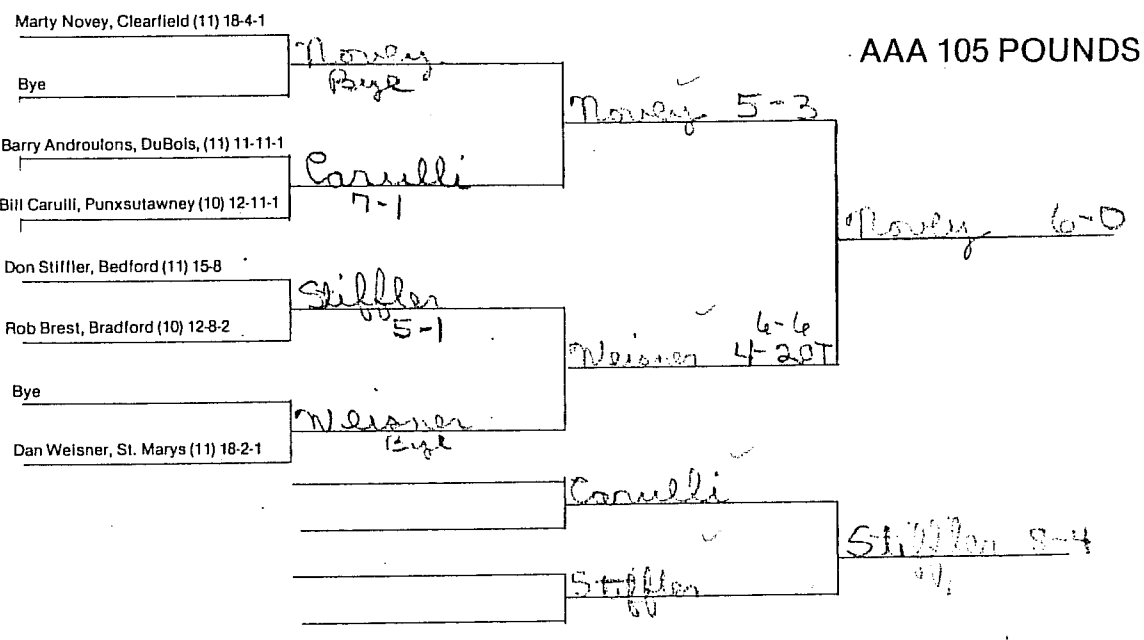
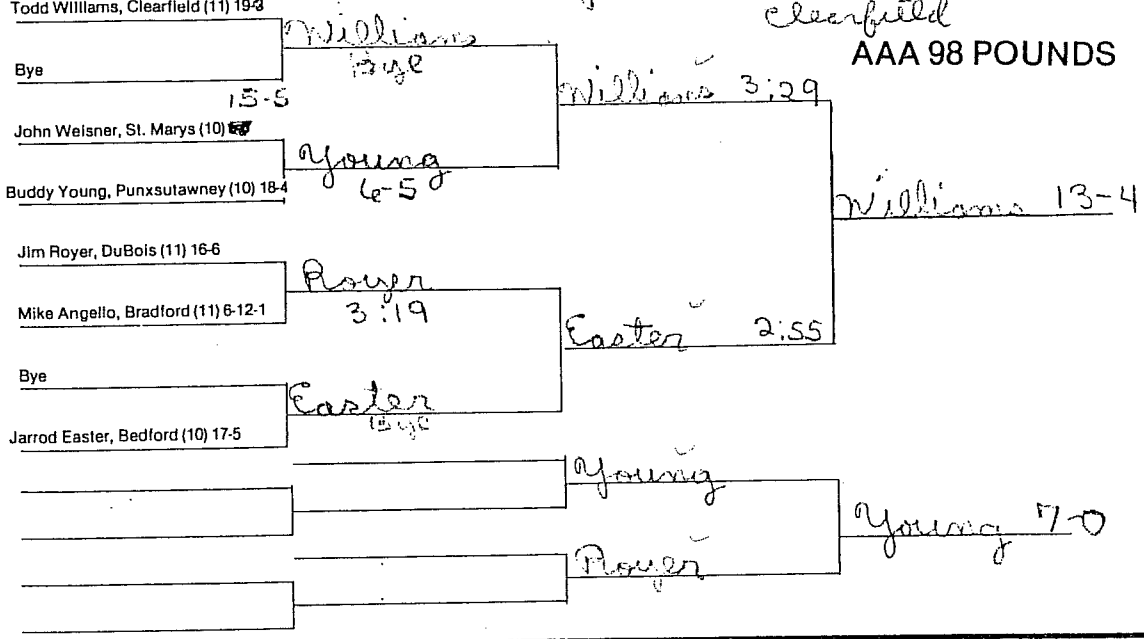

Scott Collins, Clearfield (11) 20-0

Bye

Collins  
Bye

Collins - Default .01

AAA 119 POUNDS

Don Shenosky, Punxsy (10) 3-15

Jim Bergess, Bradford (11) 8-9-1

Steve Hardinger, Bedford (11) 10-13

Rich Temburlin, DuBois (12) 0-8

Bye

Tim Wittman, St. Marys (10) 19-1

Hardinger  
13-2

Bergess  
8-4

Wittman  
Bye

Wittman 1:31

Hardinger

Bergess

Collins 7-1

Hardinger 3-5

Dave Crawford, DuBois (11) 18-6

Bye

Bill Creps, Bedford (11) 9-9-1

Tony Sherwin, Punxsy (12) 12-10

Darin Tkacik, Clearfield (12) 14-8

Todd Wurm, Bradford (12) 7-12-1

Bye

Tim Wurm, St. Marys 14-5-1

Crawford  
Bye

Sherwin  
3:43

Tkacik 4:21

Wurm  
Bye

Crawford 7-5

Wurm 9-4

Sherwin

Tkacik

AAA 126 POUNDS

Crawford 6-1

Tkacik 8-6

Scott Luzler, Clearfield (12) 20-1

Bye

Kevin Keane, Bradford (11) 6-7

Jim Helt, Bedford (11) 10-6

Jeff Lewis, St. Marys (12) 7-3

Ron Rossev, Punxsy (12) 3-5-1

Bye

Brian Wruble, DuBois (10) 18-8

Luzler  
Bye

Keane  
17-12

Lewis  
3-0

Wruble  
Bye

Luzler 1:25

Wruble 6-6

Keane

Lewis

AAA 132 POUNDS

Luzler 2-3

Keane 4:40

John Anderson, St. Marys (12) 19-2

Bye

Anderson  
Bye

AAA 138 POUNDS

Ron Sheriff, Punxsy (10) 7-13-2

Jeff Clark, Bradford (12) 11-10

Clark  
11-11  
4-2 OT

Anderson 5-3

Anderson 7-6

Andy Lingle, Clearfield (12) 16-6

Darren Alliso, DuBois (11) 1-11

Single  
14-4

Barefoot 9-5

Bye

Bedford  
Keith Barefoot, (11) 20-4

Barefoot  
Bye

Clark

Single 6-3

Single

John Stroub, Bedford (12) 18-4

Bye

Stroub  
Bye

AAA 145 POUNDS

Rod Shaffer, Punxsy (10) 4-17

Brian Vokes, Clearfield (11) 2-1

Vokes  
3:19

Stroub 17-3

Stroub 2:58

John Cashmer, St. Marys (10) 8-6

Jeff Coles, Bradford (12) 6-12

Cashmer  
3:55

Whitehouse 12-2

Bye

Eric Whitehouse, DuBois (10) 6-12

Whitehouse  
Bye

Vokes

Vokes 12-5

Cashmer

Gary Diehl, Bedford (12) 21-2

Bye

Diehl  
Bye

AAA 155 POUNDS

Doug Melzer, Punxsy (10) 1-15

Tim Keane, Bradford (12) 5-4

Melzer  
2:54

Diehl 20-8

Diehl 9-1

Mike Goslee, DuBois (11) 10-9

Bill Coudriet, St Marys (12) 5-7

Goslee  
7-6

Goslee 3-2

Bye

Tom Rauch, Clearfield (12) 18-6

Rauch  
1:40

Keane

Rauch 1:45

Rauch



Scott Goad, Bedford (12) 16-5

Bye

Todd Ferrara, Punxsy (11) 0-10

Mike McGee, Bradford (10) 7-11

Bill Waring, Clearfield (12) 2-2

Scott Merritt, St. Marys (9) 9-7

Bye

Tom Glasi, DuBols (12) 14-9

Goad  
Bye

McGee  
7-27

Waring  
7-5

Glasi  
Bye

Goad 22-9

Waring 3-1

McGee ✓

Glasi

AAA 167 POUNDS

Goad 5-2

Glasi 2:49

Mike Crissman, DuBols (11) 16-6

Bye

David Catalano, Punxsy (11) 9-15

Alan Marshall, Bedford (12) 12-9-1

Scott Taylor, St. Marys (11) 13-5

John Addis, Bradford (10) 2-5

Bye

Mike Owens, Clearfield (11) 14-7-1

Crissman  
Bye

Marshall  
18-2

Taylor  
2:17

Owens  
Bye

Crissman ✓  
4-3

Owens ✓  
5:06

Marshall

Taylor ✓

AAA 185 POUNDS

Owens 6-2

Taylor 5-4

Don Arrgood Punsy (12) 9-7-3

Bye

Neil Bloom, DuBols (10) 2-4-1

Steve Selfert, Bedford (10) 2-2

Joe Marrison, Clearfield (12) 9-9-1

Dean Wolfe, St. Marys (10) 0-2

Bye

Paul Webster, Bradford (11) 12-9

Arrgood  
Bye

Selfert  
2:14

Marrison  
Bye

Webster  
Bye

Arrgood 6-1

Marrison 19-1

Selfert ✓

Webster ✓

AAA HEAVYWEIGHT

Marrison 7-2

Selfert 2:43