



Whiteriver

decks for living

INSTALLATION INSTRUCTIONS:

Portland Decking -
Ultrashield Decking -
Portland Handrail System -

Deck Preparation

Planning Your Deck

Designing and building a deck can be a fun and a rewarding experience. You probably have given some thought as to what you want in a deck, now is the time to really visualise it. What will your deck be used for, relaxing, entertaining, will you put garden seating, BBQ, tables with a parasol on it and how many people might you have on your deck? Will there be children and elderly people using it?

These are the questions you need to look at before starting.

- (1) Where will I install the deck?
- (2) What size do I want the deck?
- (3) Which deck board do I like best?
- (4) Which direction should the boards run?
- (5) Which substructure will I use: Hardwood, *Steel or Aluminium joists?
*Steel / Aluminium joists >2mm: A hole must be pre drilled in the joist and specific Steel Joist Installation Kits must be used.

Follow the fitting instructions carefully, see full instructions on www.wrg.ie technical information before starting.

Location and Deck Size

When deciding the size of your deck, look around at the space you have, your house, the size of your garden and what proportion of deck will enhance and improve the look of it. Your deck should have a southerly aspect. Is the ground level or falling? How close to the house would I like the deck? When deciding on the size of deck you need to take into account that the deck boards are 3600mm in length. You can make a deck any length, but you want to avoid having a deck with very short end boards. Therefore it's important to plan your exact deck layout.

Tools Required

Whiteriver Decks can be installed using the same tools that you would use for fitting any timber deck. • Tape Measure • Electric Saw • Level • Square • Cordless Drill • drill bits • Building Line • Safety Goggles

General

Composite decking has a composition of 60% timber, 30% HDPE Plastic and 10% Resins / Pigments etc. While the timber element is very stable (it is kiln dried at very high temperatures to remove the cell structure), the HDPE expands and contracts on the length of the board in line with changes in temperature and humidity. It is necessary to leave a perimeter gap of 10mm around where the deck meets fixed objects/obstructions and also a 5mm spacing must be left at each short board end to allow for normal seasonal movements.

See full instructions on www.wrg.ie technical information before starting.

Design

Once you have made a decision on the above, now you need to decide on the deck design. A deck that is well designed can do amazing things to your home.

First decide on the direction you would like the boards to run please note boards must drain along the length of the board, the minimum fall required is 1.66% (1:60 fall) to allow water drain off the boards e.g. a 5 metre deck should have a fall of 83mm across the deck. **Do not install the decking flat.** Will there be steps? Would you like handrails around it? What colour will suit your garden and house best?

Ventilation and Site Conditions

There should be good drainage under the deck and all topsoil should be removed and replaced with clean stone, unless the deck is at least 1000mm above ground level with open ventilation under the deck. No soil should meet the deck boards or under structure. The ground/substructure should be properly supported - please consult with an engineer if you are unsure. Whiteriver composite decking products CANNOT be directly installed onto a flat surface. It must be installed onto a substructure, so there is adequate and unobstructed air flow under the decking to prevent excessive water absorption.

Good ventilation under your deck is key to it performing well in the long term.

For non screed and screed surfaces, plan a minimum of 100mm (4 inches) of continuous net free area under the decking surface. This is required to allow for adequate ventilation on all deck types so air can circulate freely between adjacent joist members to promote drainage and drying. Air must have an entry point and exit point to the sub construction.

Joist should be built up on two criss cross layers or the joist should be supported with plastic pedestals to allow for air movement. For small balcony areas, less than 10m², it is possible to have a lower clearance provided sufficient drainage and air movement can be provided. For balcony projects, we recommend getting the design reviewed by an engineer.

Please note areas that are walled in on all sides are not suitable for deck installation as there will not be enough air movement under the deck, unless ventilation through the walls is provided for the undercarriage. If there is any dampness under the deck, it can lead to mould build up underneath the deck and excessive swelling, expansion and contraction in the boards. In summary, it is vital that the area underneath the deck is free draining and per above, adequate ventilation is provided for.

If you require any technical advice, please contact our sales office on **Email: sales@wrg.ie**

Direction of Deck

There is no correct deck direction, it is purely personal preference but whatever you choose dictates the sub-frame design and configuration. Things to consider: Think about where you or your guests will view the deck. Looking along the length of the boards will make the deck look longer, while looking across the boards creates an illusion of width. All boards are 3600mm long and each side of the board contains different groove or pattern.

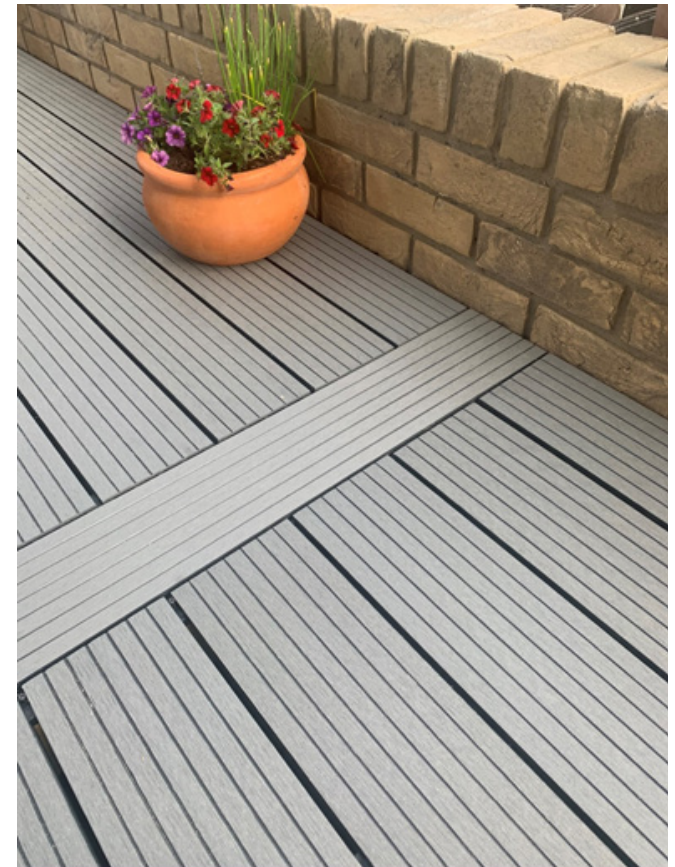
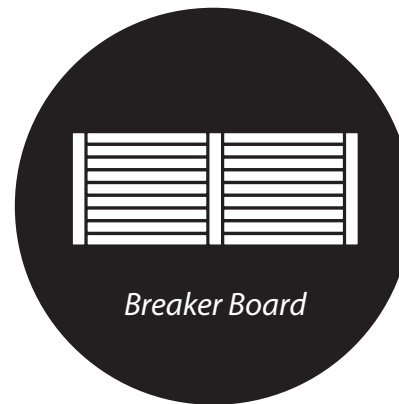

Composite Decking Installation Do's & Don'ts

Please read the instructions fully before starting to install. Failure to install composite decking correctly will result in the deck becoming structurally unstable.

A 10mm gap around the whole deck must be left for expansion and a 5mm gap between board ends.

| | | | |
|--|---|---|---|
| <p>✓</p> <p>LEAVE A 10MM GAP AROUND DECK PERIMETER TO ALLOW FOR MOVEMENT</p> | <p>✓</p> <p>ENSURE THERE IS GOOD AIR CIRCULATION AROUND AND UNDER THE WHOLE DECK</p> | <p>✓</p> <p>LEAVE A 5MM EXPANSION GAP BETWEEN BOARD ENDS</p> | <p>✓</p> <p>DOUBLE JOIST WHERE BOARD ENDS MEET. EACH BOARD END SHOULD HAVE ITS OWN CLIP & JOIST</p> |
| <p>✓</p> <p>USE STEEL INSTALLATION KITS FOR FIXING TO STEEL OR ALUMINIUM JOISTS</p> | <p>✓</p> <p>USE GOOD QUALITY JOISTS OR ALUMINIUM. PRE DRILL FASCIA BOARDS BEFORE FIXING</p> | <p>✓</p> <p>USE RECOMMENDED CLIPS TO SECURE BOARDS TO JOISTS</p> | <p>✓</p> <p>PRE DRILL STEEL JOISTS TO RECEIVE STAINLESS STEEL SCREWS</p> |
| <p>✓</p> <p>ACCLIMATISE BOARDS TO THE ENVIRONMENT FOR 3 DAYS PRIOR TO INSTALLATION</p> | <p>✓</p> <p>LEAVE A NATURAL FALL TO ALLOW WATER TO DRAIN OFF BOARDS</p> | <p>✓</p> <p>USE LOCKING CLIPS TO CONTROL EVEN EXPANSION & CONTRACTION ALONG THE LENGTH OF THE BOARD</p> | <p>✓</p> <p>20MM MAX. OVERHANG FROM JOIST AT DECK EDGES WITH LAST FIXING CLIP MAX 30MM FROM BOARD END</p> |
| <p>✗</p> <p>SCREW DIRECTLY THROUGH BOARDS</p> | <p>✗</p> <p>STORE BOARDS ON SOLID OR UNEVEN SURFACES</p> | <p>✗</p> <p>INSTALL IN AREAS THAT HAVE WALL ON ALL SIDES</p> | <p>✗</p> <p>LEAVE BUTT JOINTED AND CUT ENDS UNSEALED</p> |



Bridging supports can be put in as required.

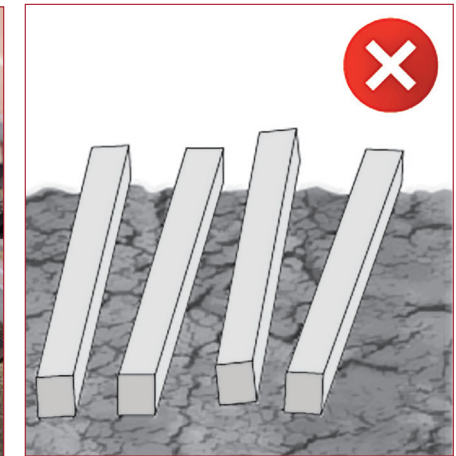
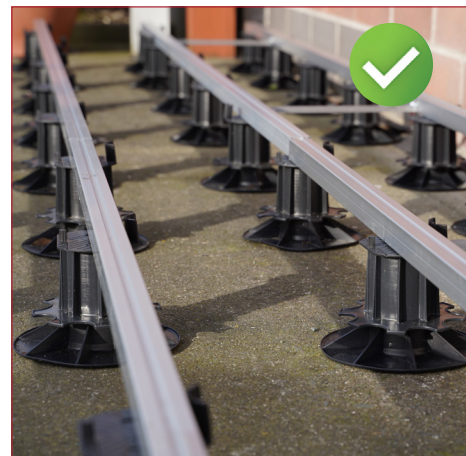

A structurally sound sub frame must be installed ensuring there is no movement prior to fixing boards to the joists. A 1.66% (1:60) fall to allow water to drain and a minimum 100mm free air space between the boards and the ground beneath to allow sufficient airflow to prevent the build up of moisture is essential.



Composite decking should only be installed using correct clips and fixings. Failure to do this will effect the structure of the deck as well as warranty. Never screw directly through the boards. Steel joists >2mm must be pre drilled and specific Steel Joist Installation Kits must be used.



The overhang of the board should be a maximum of 20mm.

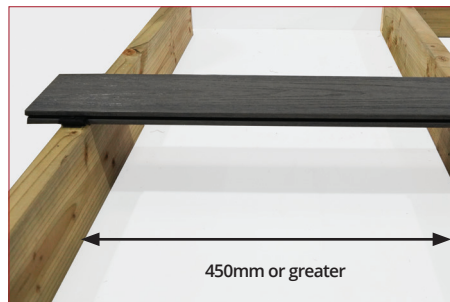
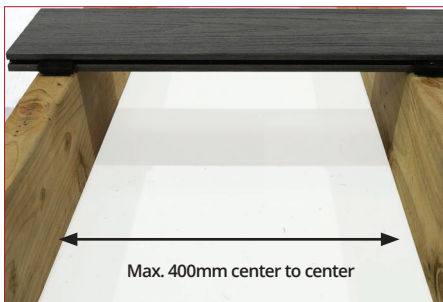

Joists must be set to a maximum of 400mm centres. This is to ensure stability and also to avoid warping and cracking of the deck boards.

Note: 400mm centres are recommended for residential installations, 300mm is recommended for commercial.

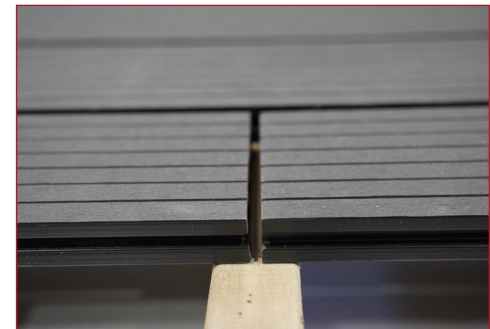
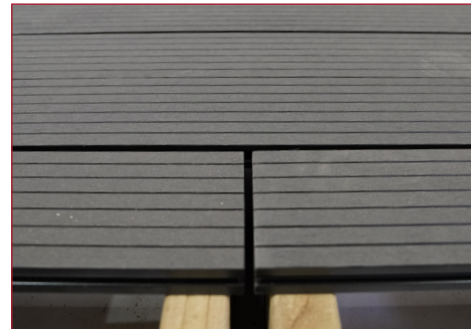

Board ends butted together must be supported by separate joists and have a min 5mm gap for expansion. Failure to do this may result in structural failure swelling and warping. There should be a spacing gap left between the double joists to allow rainwater/debris to fall through the boards.

Key points on how to fit your composite decking correctly.

Following on from our Dos and don'ts we explain the issues that can arise if decks are not installed or maintained correctly.



What happens if I leave soil under my deck area ?

The soil will retain a lot of moisture and this will affect your decks performance. You need to remove the soil and then stone the area below your deck. You also need to ensure the area is free draining. If your deck is being raised by more than 1m and the area is being left completely open underneath the ground type is less important.

What happens if water pools under my deck ?

Similar to the reasons mentioned above for soil, it will have a negative affect on your substructure and deck boards performance. If in a balcony area, it may be a sign that there may be a blocked drain.

What happens if I fit my deck flat with no fall ?

If you fit your deck flat, the water will not be able to drain off your deck boards easily and your deck will remain wet for much longer periods after it rains. This will cause your deck to catch more dirt and will also encourage over time mould growth to develop.

What happens if I fit my deck with north or east facing orientation?

Your deck will get much less sun light and will be more prone to being damp and wet for longer. If you are fitting in a north facing area, your deck will require more regular cleaning.

What happens if I don't provide ventilation under my deck ?

The area under your deck will become damp and this may cause your substructure to rot or corrode over time, the decking will also expand and contract a lot more as the excess moisture will pass into the decking boards. Your substructure therefore needs ventilation for 2 reasons.

What happens if I don't leave expansion gap of 5mm at board ends or 10mm around perimeter walls ?

Composite decking will expand and contract as the climate changes. If there is no room for the boards to expand, they will push against each other or the wall and eventually they will develop cracks.

What happens if I don't use a double joist where board ends meet ?

The reason you use a double joist where board ends meet is that the water can drain off the board ends freely and fall to the ground. The board ends are also properly supported with clips. If the board ends are left resting on the joist there is the risk that they will absorb excess moisture causing the boards ends to swell and expand.

What happens if I don't use one locking clip per board that is provided in the installation kit?

The boards may gradually slide along the normal clips and leave a big gap at one end. The teeth on the locking clip help control the boards movement, it is vital that one clip with teeth catches each board close to its mid-point.

What happens if I screwfix other items through the deck boards ?

This will create a pressure point and the boards may crack over time as there may not be enough expansion room. Handrail systems should always be fixed to the substructure and not through the deck boards.

What happens if I don't clean my deck ?

Your deck will remain fine in the short term but over time the deck will collect dirt and pollen and eventually as the deck gets dirtier there will be some green or black mould growth. Your deck never needs to be painted or sealed but it is important to have a cleaning programme.



We hope the above helps you understand why getting your deck installation correct is the key to you having a great outdoor area to enjoy.

Installation Guide

- Make sure you have ordered enough material, so as not to be short. Allow for about 5% waste. Diagonal installations will have a higher waste factor.
- Store decking on site for at least 3 days, raised off the ground, lying flat and keep it dry.
- Ensure there is adequate ventilation under the deck. Air should have an entry point and exit point to the subconstruction.
- Make sure you allow for expansion of the deck. An expansion gap of 5mm must be allowed where board butt ends meet and a 10mm gap should be left where boards meet fixed points eg. walls, pillars or railing posts. No objects e.g. post and railing systems etc. should be fixed directly to/through the deck as this will prevent seasonal movement. These should be fixed to the substructure.
- Each board end must sit on it's own independent joist with a 5mm expansion gap at board ends per above. There should be a 10-25mm gap between each joist to allow for water/ debris to fall straight through.
- There should be good drainage under the deck.
- There should be a minimum fall of 1.66% (1:60) along the deck boards to allow for water to drain freely.
- It is essential to use a locking clip on the joist nearest the centre of every board. This minimises the amount of expansion that the board can do.
- Whiteriver decking is approved for use over joist centres of maximum 400mm/16" (300mm/12" in commercial use).
- Cantilever / overhang of deck board from joist at deck edges should be no greater than 20mm with the last securing clip no more than 30mm from board end to prevent cupping.
- Read the full set of instructions on www.wrg.ie technical information before starting.

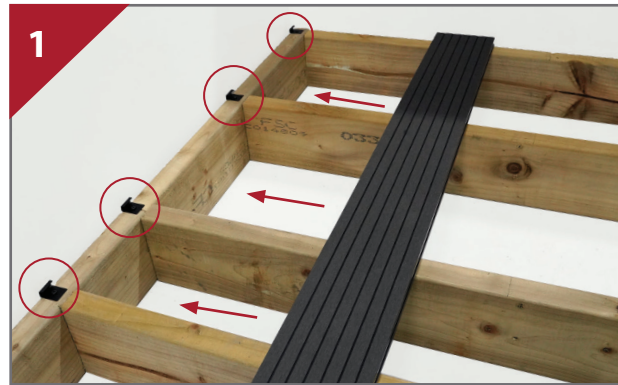

Secure start/end clips in line with each joist. Please note an expansion gap of 10mm must be placed around any fixed objects within the decking e.g. stair case, post brackets and any permanent fixtures that may prevent the decking expanding and contracting naturally. Where two boards join together on the first row, a starter/end clip must be used on each board with a 5mm expansion gap on the short end. Hollow deck boards are not suitable for face fixing. Push the first deck board into the start/end clip. Check that the board is straight and fully inserted into the clip.

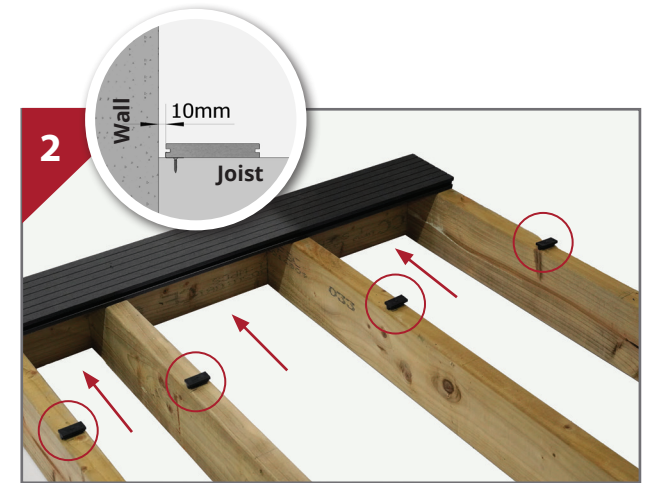

Insert a standard clip into each deck board in line with joist and screw fully but do not over tighten.

Note: A locking clip will need to be installed on each deck board per point 4.



Push the second row of boards into the previous installed row of boards making sure that the deck board grooves are in tight on the clips. Continue to keep inserting clips and boards in this way (using one locking clip per board).



It is very important to install one locking clip per board onto the joist nearest the centre of the board. This helps maintain a consistent expansion gap at the short end. Failure to use the locking clip will result in uneven gapping at short ends. **Attn: Each board only requires one locking clip in the middle. The teeth should always face the same direction.**

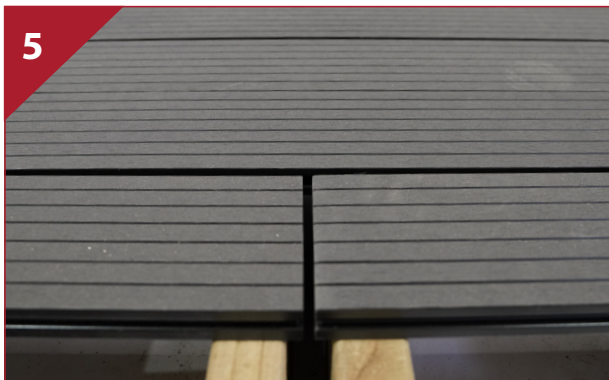

When butt jointing boards along the length of the deck you must leave a 5mm gap for seasonal expansion and contraction - see diagram above. Note comments on point 6 regarding double joisting. Boards must not meet across one single joist and must be sealed to prevent swelling, cupping and splitting.



All board ends should be on their own independent joists with their own clip i.e. when butt jointing boards, sister joisting must be used. **This is to ensure that the board will not slide off the joist - failure to do so will void the warranty. Also there needs to be a minimum of 10 -25mm between the sister joists per diagram for water to go down between the joists or swelling could occur at the ends.** UltraShield board ends meeting across sister joists should be sealed with a polyurethane matt exterior varnish to prevent end swelling, cupping and splitting.



If not framed by wall or building on each side, the second last row of boards can be slid into position after you have fixed the last row and the clips for the second last row have been fixed into position.



For the last row of boards use a start/end clip in line with each joist. You need to use these clips even if you putting on a fascia board. If you can not slide in the board, the boards can be fixed with screw at 45 degree angle. Important: the screw hole must be predrilled .

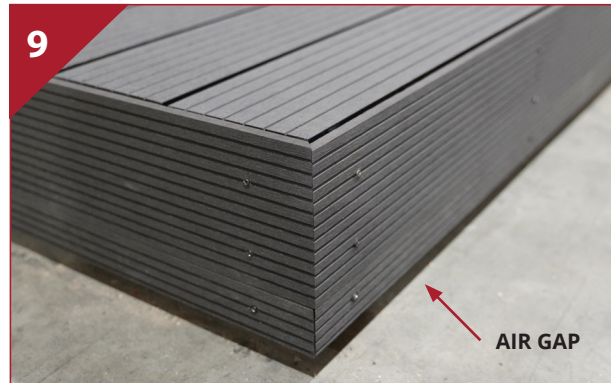

You can use a solid fascia plank for a great looking finish. It is very important to predrill all composite material prior to fixing with a hole slightly bigger than the screw. Fix in two stainless steel screws into the substructure at intervals of 300-400mm - the fascia must be predrilled with a countersunk hole and fixed to a solid timber plank in all areas (not directly to the butt ends of exposed joists). **You must leave a minimum 40mm gap between the bottom of the fascia and the ground to allow for ventilation.**

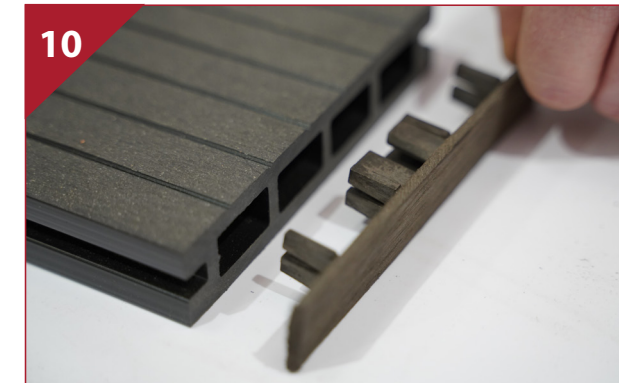

Moisture can penetrate to the core in the end-cut area and could cause swelling, cupping and cracking at the edge area. Our end pieces are made from durable material with high impact resistance under harsh weather conditions. To prevent moisture penetration we recommend:
Nevada solid board: Seal all cut ends with a water based polyurethane matt exterior varnish to the full surface of all end-cuts.
Hollow boards: End Pieces should be used at perimeter and sealed all round with outdoor silicone sealant.

Note: It is very important to provide ventilation to enter the under side of our deck when finishing off the side trims.

Breaker Board Installation

Diagrams below show how framework and installation of the breaker board respectively. The framework uses a ladder joist installation where the user is building a frame perpendicular for the board that will be running down it.

The below breaker board design ensures the water runs off the board end and down between the joists. The board ends should not rest on the timber as it will absorb moisture.



Important: All Ultrashield board ends meeting the breaker board or at deck end should be sealed with a water based polyurethane matt exterior varnish to prevent moisture penetrating the board core. The boards should be predrilled with a 3mm drill bit before screws are fixed at 45 degree angle to fix the breaker board. Its important to predrill before screwing as this prevents the boards cracking later. A starter clip can be used on one side of breaker boards.

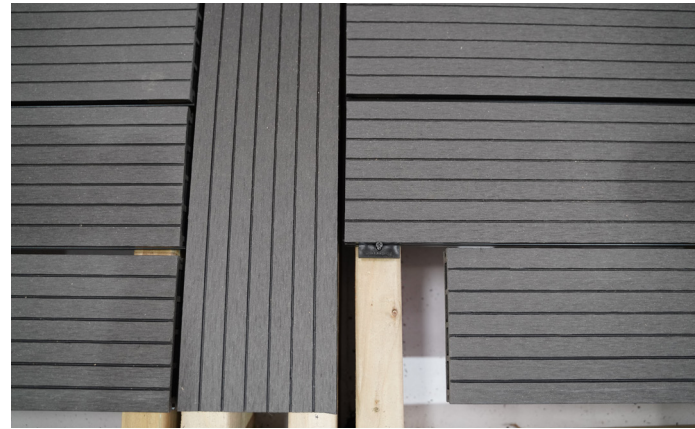

Note: Gap for water to run off board ends to the ground.

Fascia Board Installation

Installing against the width and length of decking

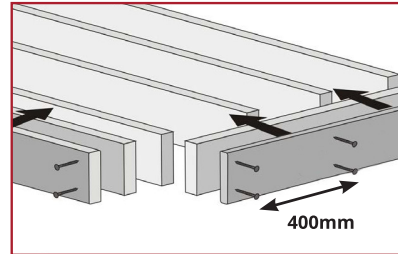

Fascia boards need to be fixed at installed on 400mm centres to prevent warping or buckling. All fascias need to use two screws 40mm away from the ends regardless of the thickness.

First, pre-drill 3mm holes in the fascia board before face fixing with screws. This drilling allows for the fascia board to expand and move slightly. The fascia board will then be installed into the joist or side board.

Note: NEVER install the fascia by drilling into the decking ALWAYS install the fascia into the joist and ALWAYS pre-drill the fascia with a countersunk hole.

Good ventilation under the deck is key to it performing well in the long term. DO NOT close off air flow around the perimeter of the deck by fixing fascia too close to the ground. Provide vents if needed.



Stair Tread Installation

Stair treads must meet requirements by Government Building Standards - please consult Department of Housing, Planning and Local Government.

A minimum of four (4) stringers are required. Overhang on a stair tread should not exceed more than 16mm. Joist centres on steps are 300mm.

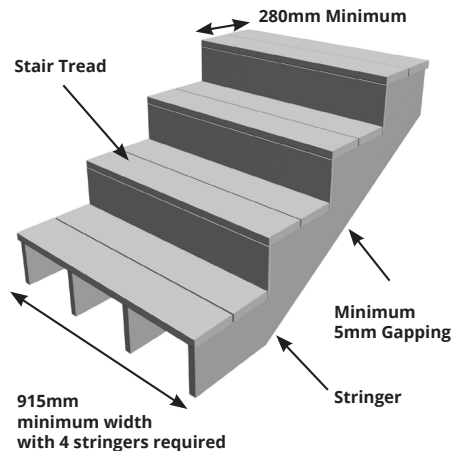

First, determine how many boards your stair is going to take to finish (including clip spacing of 6mm between boards) and then you can start to measure where the starter clip will go. Use a white chalk line (NEVER USE COLOURED CHALK) to ensure that all starter clips are lined up on each joist as shown in **Diagram 1**.

Note: The stair tread board can only cantilever/overhang 16mm. If this is exceeded the warranty will be voided.

Place stair tread board over all the starter clips and push down as shown in **Diagram 2**.

Now that the starter clips are inside the underside of the stair tread, the final step is to push forward to ensure that it is secured into place as shown in **Diagram 3**.

Now take the next board and have it situated behind the stair tread board as shown in **Diagram 4**.

Slide the clips into the two grooves and glide them along until they are on their respective joists and then screwing down onto the joists as shown in **Diagram 5 & 6**.

Finally, finish your last board by face fixing into the board at every joist as shown in **Diagram 7**.

Note: Remember to pre-drill before face fixing into the board. Also face fixing must happen at a 90 degree angle and must be at least 40mm by 40mm from the ends and the width of the board. All pre-drilling must be with a countersunk bit.

Diagram 8 shows a completed staircase from the side to get a better idea of how the final installation will look.

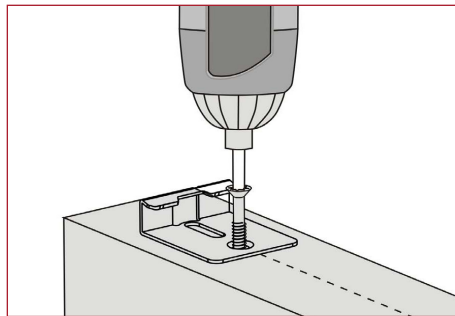

Diagram 1

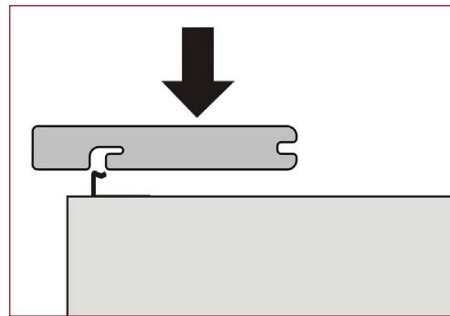

Diagram 2

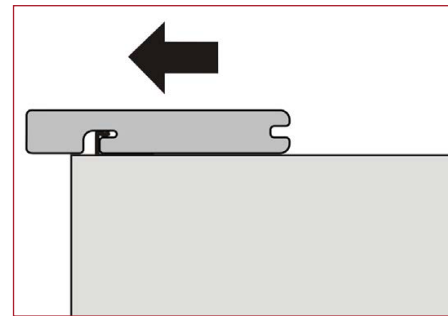

Diagram 3

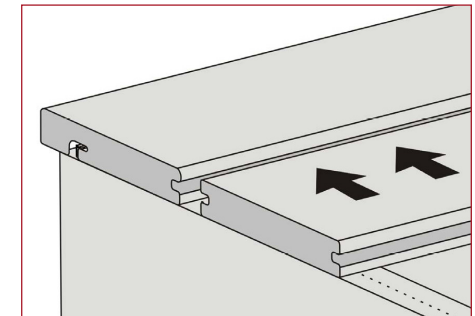

Diagram 4

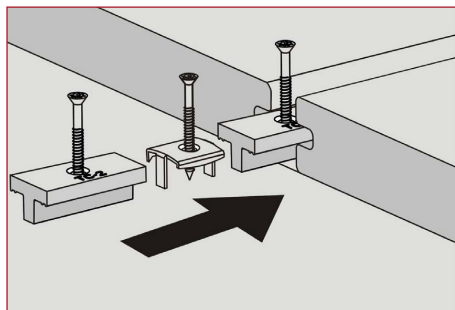

Diagram 5

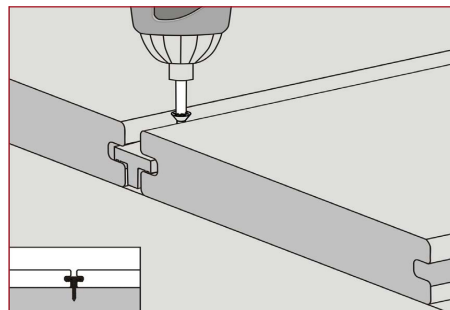

Diagram 6

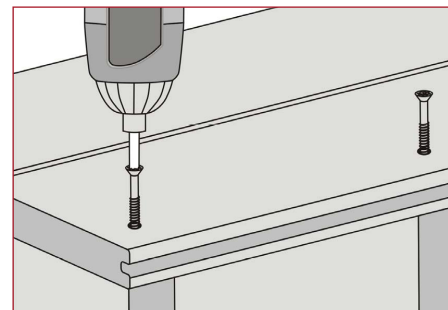

Diagram 7

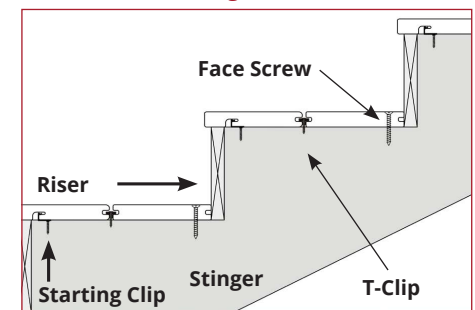
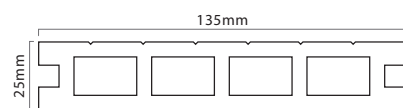

Diagram 8

Technical Data

MONTANA

Montana Composite Decking.
Available in Fired Earth, Anthrazit, Charcoal and Soft Grey.



| Test Items | Requirement | Result |
|-------------------------------|---|--|
| Max Load | Mean \geq 3300 Min \geq 3000 | Mean 4619 N Min 4409 N |
| Deflections under 500 N | Mean \leq 2.0mm Min \leq 2.5mm | Mean 1.11mm Min 1.14mm |
| Swelling and Water Absorption | Mean Swelling \leq 4.0% in thickness \leq 0.8% in width \leq 0.4% in length Water Absorption Mean \leq 7% Max \leq 9% | Mean Swelling \leq 0.08% in thickness \leq 0.02% in width \leq 0.01% in length Water Absorption Mean \leq 1.79% Max \leq 1.98% |
| Creep Behaviour | Known Span in use Mean $\Delta S \leq$ 10mm Max $\Delta S \leq$ 13mm Mean $\Delta Sr \leq$ 5mm | Span: 400mm Mean $\Delta S \leq$ 3.29mm Max $\Delta S \leq$ 3.53mm Mean $\Delta Sr \leq$ 0.74mm |
| Joist Spacing | Span: 400mm | |

ARIZONA

Arizona Composite Decking.
Available in Soft Grey only.

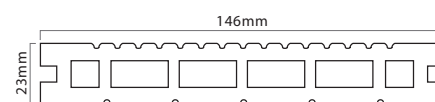

| Test Items | Requirement | Result |
|-------------------------------|---|--|
| Max Load | Mean \geq 3300 Min \geq 3000 | Mean 3759 N Min 3595 N |
| Deflections under 500 N | Mean \geq 2.0mm Min \geq 2.5mm | Mean 1.35mm Min 1.44mm |
| Swelling and Water Absorption | Mean Swelling \leq 4.0% in thickness \leq 0.8% in width \leq 0.4% in length Water Absorption Mean \leq 7% Max \leq 9% | Mean Swelling \leq 0.09% in thickness \leq 0.02% in width \leq 0.01% in length Water Absorption Mean \leq 1.66% Max \leq 1.82% |
| Creep Behaviour | Known Span in use Mean $\Delta S \leq$ 10mm Max $\Delta S \leq$ 13mm Mean $\Delta Sr \leq$ 5mm | Span: 400mm Mean $\Delta S \leq$ 5.00mm Max $\Delta S \leq$ 5.17mm Mean $\Delta Sr \leq$ 2.33mm |
| Joist Spacing | Span: 400mm | |

NEVADA

Nevada Composite Decking.
Available in Soft Grey and Anthrazit.

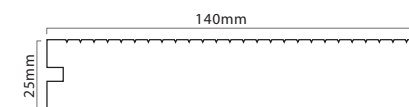

| Test Items | Requirement | Result |
|-------------------------------|---|--|
| Max Load | Mean \geq 3300 Min \geq 3000 | Mean 7716 N Min 7514 N |
| Deflections under 500 N | Mean \geq 2.0mm Min \geq 2.5mm | Mean 0.72mm Min 0.80mm |
| Swelling and Water Absorption | Mean Swelling \leq 4.0% in thickness \leq 0.8% in width \leq 0.4% in length Water Absorption Mean \leq 7% Max \leq 9% | Mean Swelling \leq 0.02% in thickness \leq 0.02% in width \leq 0.03% in length Water Absorption Mean \leq 0.1% Max \leq 0.1% |
| Creep Behaviour | Known Span in use Mean $\Delta S \leq$ 10mm Max $\Delta S \leq$ 13mm Mean $\Delta Sr \leq$ 5mm | Span: 350mm Mean $\Delta S \leq$ 0.98mm Max $\Delta S \leq$ 0.62mm Mean $\Delta Sr \leq$ 1.06mm |
| Joist Spacing | Span: 400mm | |

All above tests have been carried out by Intertek Testing Services according to European Standards EN 15534-1: 2014

Decking Calculator (No. of boards required)

| Product | 10m ² | 12m ² | 14m ² | 16m ² | 18m ² | 20m ² | 22m ² | 24m ² | 26m ² | 28m ² | 30m ² | 32m ² | 34m ² | 36m ² | 38m ² | 40m ² | 42m ² | 44m ² | 46m ² | 48m ² | 50m ² |
|---------|------------------|------------------|------------------|------------------|------------------|------------------|------------------|------------------|------------------|------------------|------------------|------------------|------------------|------------------|------------------|------------------|------------------|------------------|------------------|------------------|------------------|
| Montana | 20 | 24 | 28 | 32 | 35 | 39 | 43 | 47 | 51 | 55 | 59 | 63 | 67 | 71 | 75 | 79 | 83 | 87 | 91 | 95 | 99 |
| Arizona | 18 | 22 | 26 | 29 | 33 | 37 | 40 | 44 | 48 | 52 | 55 | 59 | 63 | 66 | 70 | 74 | 77 | 81 | 84 | 89 | 92 |
| Nevada | 19 | 23 | 27 | 31 | 35 | 38 | 42 | 46 | 50 | 54 | 58 | 61 | 65 | 69 | 73 | 77 | 81 | 84 | 88 | 92 | 96 |

UltraShield® Naturale™

UltraShield Composite Decking.
Available in Teak, Silver Grey, Antique, Walnut and Cedar.

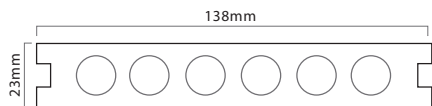

| Test Items | Requirement | Result |
|-------------------------------|--|---|
| Max Load | Mean ≥ 3300 Min ≥ 3000 | Mean 4090 N Min 3866 N |
| Deflections under 500 N | Mean ≥ 2.0mm Min ≥ 2.5mm | Mean 1.14mm Min 1.19mm |
| Swelling and Water Absorption | Mean Swelling ≤ 4.0% in thickness ≤ 0.7% in width ≤ 0.3% in length Water Absorption Mean ≤ 7% Max ≤ 9% | Mean Swelling ≤ 2.40% in thickness ≤ 0.06% in width ≤ 0.08% in length Water Absorption Mean 1.9% Max 2.0% |
| Creep Behaviour | Known Span in use Mean ΔS ≤ 10mm Max ΔS ≤ 13mm Mean ΔSr ≤ 5mm | Span: 350mm Mean ΔS 2.0mm Mean ΔSr 1.5mm |
| Joist Spacing | Span: 350mm | |

UltraShield® Naturale™ Wide Board

UltraShield Naturale Wide Plank Composite Decking.
Available in Old Mist and Pebble Grey.

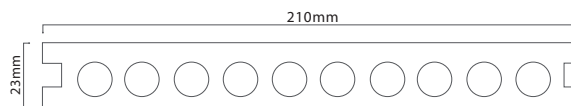

| Test Items | Requirement | Result |
|-------------------------------|--|---|
| Max Load | Mean ≥ 3300 Min ≥ 3000 | Mean 4090 N Min 3866 N |
| Deflections under 500 N | Mean ≥ 2.0mm Min ≥ 2.5mm | Mean 1.14mm Min 1.19mm |
| Swelling and Water Absorption | Mean Swelling ≤ 4.0% in thickness ≤ 0.7% in width ≤ 0.3% in length Water Absorption Mean ≤ 7% Max ≤ 9% | Mean Swelling ≤ 2.40% in thickness ≤ 0.06% in width ≤ 0.08% in length Water Absorption Mean 1.9% Max 2.0% |
| Creep Behaviour | Known Span in use Mean ΔS ≤ 10mm Max ΔS ≤ 13mm Mean ΔSr ≤ 5mm | Span: 350mm Mean ΔS 2.0mm Mean ΔSr 1.5mm |
| Joist Spacing | Span: 350mm | |

UltraShield® Textured

UltraShield Textured Composite Decking.
Available in Sapele and Graphite.

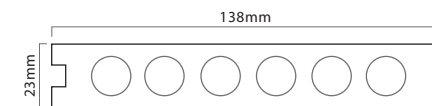









| Test Items | Requirement | Result |
|-------------------------------|--|---|
| Max Load | Mean ≥ 3300 Min ≥ 3000 | Mean 4090 N Min 3866 N |
| Deflections under 500 N | Mean ≥ 2.0mm Min ≥ 2.5mm | Mean 1.14mm Min 1.19mm |
| Swelling and Water Absorption | Mean Swelling ≤ 4.0% in thickness ≤ 0.7% in width ≤ 0.3% in length Water Absorption Mean ≤ 7% Max ≤ 9% | Mean Swelling ≤ 2.40% in thickness ≤ 0.06% in width ≤ 0.08% in length Water Absorption Mean 1.9% Max 2.0% |
| Creep Behaviour | Known Span in use Mean ΔS ≤ 10mm Max ΔS ≤ 13mm Mean ΔSr ≤ 5mm | Span: 350mm Mean ΔS 2.0mm Mean ΔSr 1.5mm |
| Joist Spacing | Span: 350mm | |

Decking Calculator (No. of boards required)

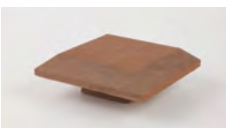

| Product | 10m ² | 12m ² | 14m ² | 16m ² | 18m ² | 20m ² | 22m ² | 24m ² | 26m ² | 28m ² | 30m ² | 32m ² | 34m ² | 36m ² | 38m ² | 40m ² | 42m ² | 44m ² | 46m ² | 48m ² | 50m ² |
|---------------------------------|------------------|------------------|------------------|------------------|------------------|------------------|------------------|------------------|------------------|------------------|------------------|------------------|------------------|------------------|------------------|------------------|------------------|------------------|------------------|------------------|------------------|
| UltraShield Naturale & Textured | 20 | 23 | 27 | 31 | 35 | 39 | 43 | 47 | 51 | 55 | 59 | 62 | 66 | 70 | 74 | 78 | 82 | 85 | 90 | 94 | 98 |
| UltraShield Wide Board | 13 | 16 | 18 | 21 | 23 | 26 | 28 | 31 | 34 | 36 | 39 | 41 | 44 | 47 | 49 | 52 | 54 | 57 | 59 | 62 | 65 |

PORTLAND RAIL COMPONENTS

Available in Soft Grey, Anthrazit & Fired Earth.

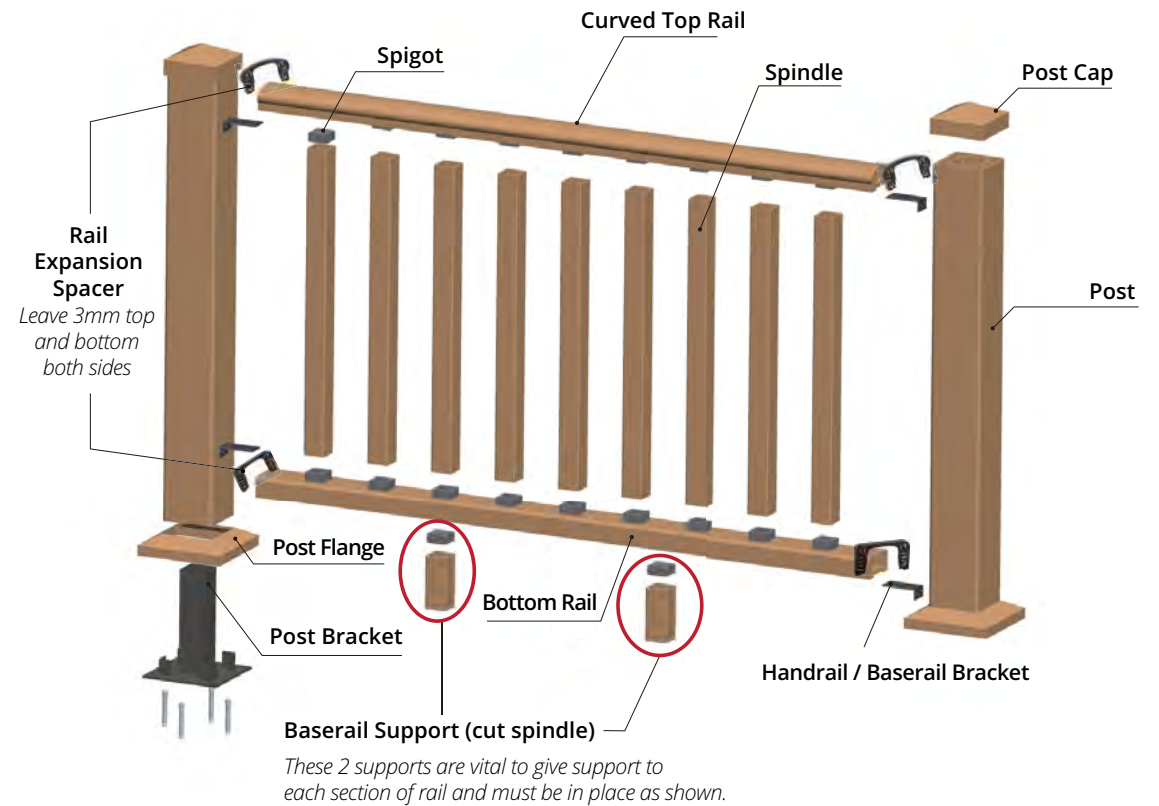
| | |
|---|---|
| <p>CURVED HANDRAIL Curved Profile 100 x 50 x 1800mm</p> |  |
| <p>RECTANGULAR BASERAIL / HANDRAIL Square Profile 90 x 45 x 1800mm Can also be used as contemporary handrail.</p> |  |
| <p>SPINDLE Including Spigot & Screws 50 x 50 x 900mm</p> |  |
| <p>HANDRAIL / BASERAIL BRACKET 10 Per Pack Secures rails to posts.</p> |  |
| <p>SQUARE POST CAP</p> |  |
| <p>POST 120 x 120 x 1200/2400mm</p> |  |
| <p>POST FLANGE Hides Post Bracket</p> |  |
| <p>POST SUPPORT BRACKET Must be fixed to substructure (Includes Screws)</p> |  |



| | |
|------------------------------------|---|
| <p>CURVED HAND RAIL Spacer</p> |  |
| <p>SQUARE HAND RAIL Spacer</p> |  |

POST & RAILINGS INSTALLATION

NOTE: IT IS IMPORTANT THAT COMPOSITE MATERIAL IS PRE-DRILLED PRIOR TO FIXING SCREWS INTO IT.

Step 1

As the diagram 2.1 below shows, firstly use expansile bolts to fix the Post Bracket in the right position of measured posts on the concrete ground or in case of timber joists, use coach screws suitable for outdoor use.

THE POST BRACKET SHOULD BE FIXED TO THE SUB-CONSTRUCTION, NOT THE DECKING.

We recommend that the spacing between two posts should be not more than 1800mm; this distance is based on the specific spacing between the spindles.

The standard spacing between spindles is 100mm. Insert the posts into the Post Bracket, then using fixing screws, fix the posts through the holes of the angle iron on the Post Bracket.

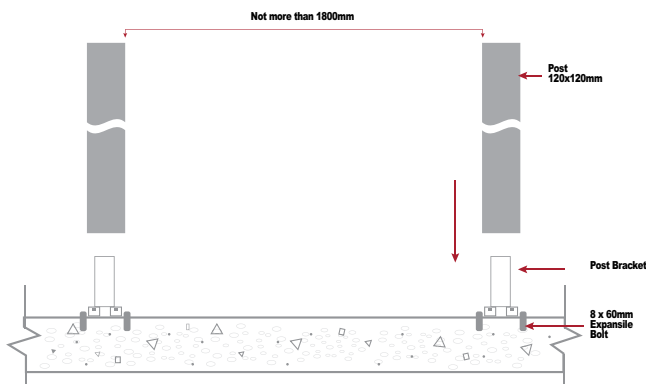

DIAGRAM 2.1

Step 2

After fixing the posts, insert the post flange to the bottom of the posts; then mark the position for the top and bottom handrail on all posts. Fix the handrail bracket on the marked position on the post, just as diagram 2.2 below shows. We recommend that the spacing between two posts should be not more than 1800mm.

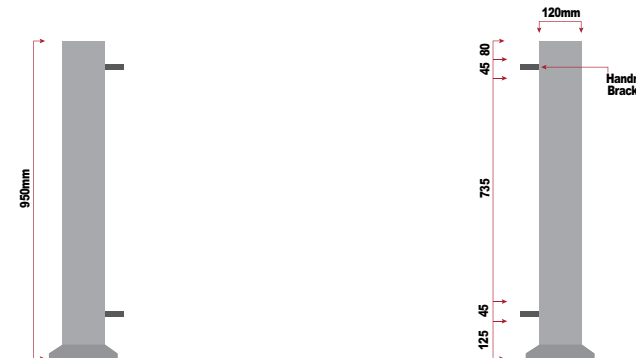

DIAGRAM 2.2

Step 3

As diagram 2.3 below shows: fix the spindle bracket / spigot on both the top and bottom handrail - the fixing spacing is based on the standard spindle spacing of 100mm. Install and fix the top and bottom handrail to the handrail bracket. Use external grade silicone adhesive in the spigot to fix securely and avoid any spindle movement.

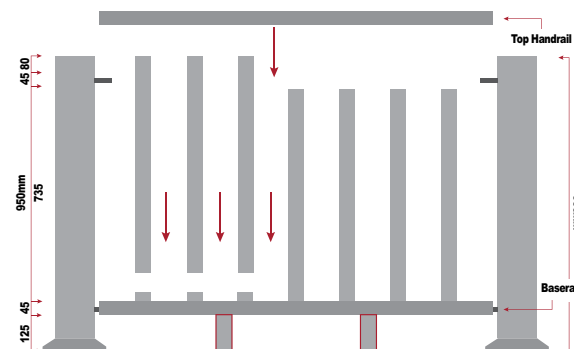

DIAGRAM 2.3

Step 4

Please install a minimum of 2 pieces of spindles below the bottom handrail as seen in the installation of spindles in diagram 2.4. These pieces must be spaced evenly to support the overall handrail section and avoid warping. **This is very important.**

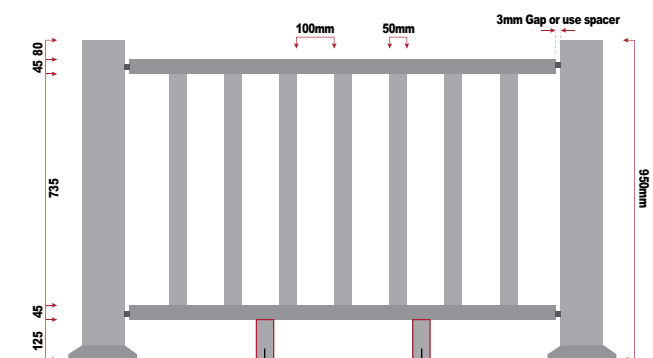

DIAGRAM 2.4

These supports are vital to the structure of each section.

Step 5

Install the post cap on top of the posts. This is to prevent water accumulating within. Now you are finished the installation of the post and handrail system. Please consult the finished drawing of post and handrail system as shown in diagram 2.5 below.

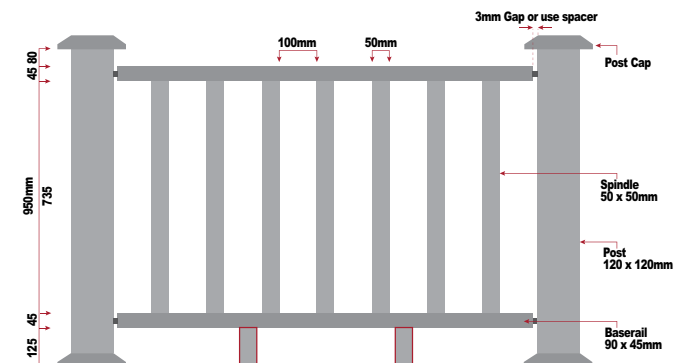

DIAGRAM 2.5

Note: Portland hand rail is only suitable for installation to a maximum of 600mm above ground level.



www.wrg.ie