

HTO

Hardness Taste and Odor Filter

1. Read all instructions carefully before operation.
2. Avoid pinched o-rings during installation by applying NSF certified lubricant to all seals (provided with install kit).
3. This system is not intended for treating water that is microbiologically unsafe or of unknown quality without adequate disinfection before or after the system.
4. Page 18 of this manual contains important maintenance procedures for the continued proper operation of your unit. These **MUST** be performed regularly for your warranty to remain valid.

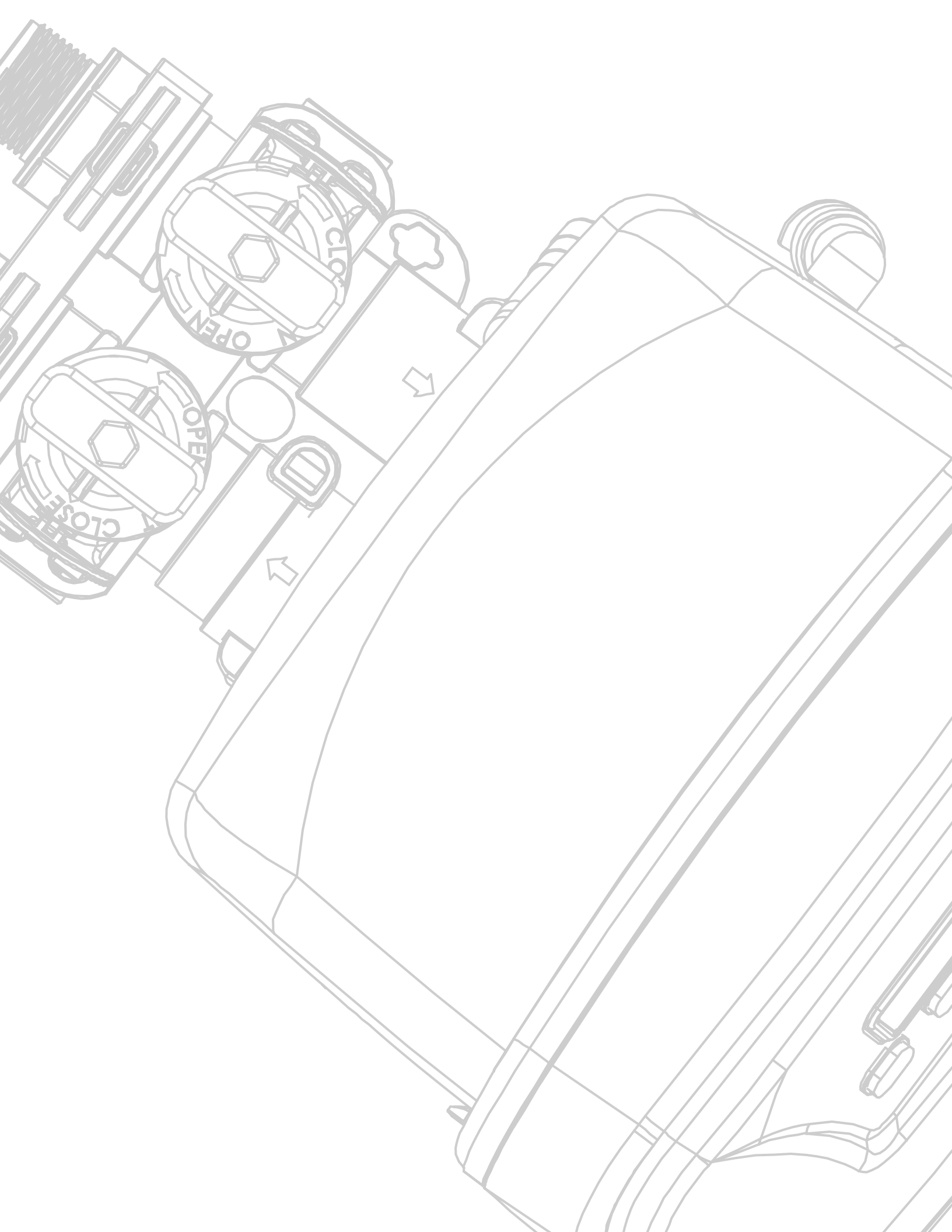

Table of Contents

READ THIS PAGE FIRST BEFORE STARTING INSTALLATION	4
COMPONENTS & SPECIFICATIONS	
SPECIFICATION	5
SYSTEM DIMENSIONS	5
BRINE TANK DIMENSIONS	6
INSTALLATION	
UNPACKING / INSPECTION	7
ASSEMBLING BRINE TANK BEFORE INSTALLATION	8
PREPARATIONS	10
INSTALLATION STEPS	11
INSTALLATION	12
OPERATION	
STARTUP INSTRUCTIONS	14
DURING REGENERATION / PLUMBING SYSTEM CLEAN-UP	16
MAINTENANCE INSTRUCTIONS AND SCHEDULE	17
REPLACEMENT	
TIMER REPLACEMENT	19
PISTON AND/OR BRINE VALVE ASSEMBLY REPLACEMENT	19
SERVICING OF PARALLEL ADAPTOR	20
METER ASSEMBLY REPLACEMENT	20
CLEAN INJECTOR ASSEMBLY	21
REPLACE MOTOR	21
CIRCUIT BOARD REPLACEMENT / REPLACE DRAIN LINE FLOW CONTROL AFTER SERVICING	22
PARTS BREAKDOWN	23
PARTS	
POWERHEAD	24
BYPASS	25
VALVE BODY	26
TANK AND VALVE CONNECTION	27
TROUBLE SHOOTING GUIDE	28
PROGRAMMING	
MASTER PROGRAMMING GUIDE	30
WARRANTY	32

READ THIS PAGE FIRST

BEFORE STARTING INSTALLATION

- ▶ Read this manual thoroughly to become familiar with the device and its capabilities before installing or operating your Water Filter. Failure to follow instructions in this manual could result in personal injury or property damage. This manual will also help you to get the most out of your filter.
- ▶ This system is intended for use on municipal water only and its installation must comply with all State, provincial or local regulations. Check with your local public works department for plumbing and sanitation codes. In the event the codes conflict with any content in this manual the local codes should be followed. Consult your licensed plumber for installation of this system.
- ▶ This water filter is designed to operate on pressures of 30 psi to 125 psi. If the water pressure is higher than the maximum use a pressure reducing valve in the water supply line to the filter.
- ▶ This unit is capable of operating at temperatures between 40°F and 110°F (4°C - 43°C). Do not use this water filter on hot water supplies.
- ▶ Do not install this unit where it may be exposed to wet weather, direct sunlight, or temperatures outside of the range specified above.
- ▶ Avoid pinched o-rings during installation by applying (provided with install kit) NSF certified lubricant to all seals.
- ▶ Filters are commonly exposed to high levels of iron, manganese, sulfur, and sediments. Damage to pistons, seals, and or spacers within the control valve are not covered in this warranty due to the harsh environment.
- ▶ It is recommended to regularly inspect and service the control valve on an annual basis. Cleaning and or replacement of piston, seals, and or spacers may be necessary depending on how harsh the conditions are. An Annual Maintenance kit (Part # 60010307) is available for this purpose
- ▶ Do not use water that is microbiologically unsafe without adequate disinfection before or after this system.
- ▶ This publication is based on information available when approved for printing. Continuing design refinement could cause changes that may not be included in this publication. TDC reserves the right to change the specifications referred to in this literature at any time, without prior notice.

INSTALL NOTES & SAFETY MESSAGES

Watch for the following messages in this manual:

NOTE

Do not remove or destroy the serial number. It must be referenced on request for warranty repair or replacement

NOTE: used to emphasize installation, operation or maintenance information which is important but does not present a hazard.



CAUTION!

Disassembly while under pressure can result in flooding.

CAUTION: used when failure to follow directions could result in damage to equipment or property.



WARNING!

ELECTRICAL SHOCK HAZARD! UNPLUG THE UNIT BEFORE REMOVING THE COVER OR ACCESSING ANY INTERNAL CONTROL PARTS

WARNING: used to indicate a hazard which could cause injury or death if ignored.

SPECIFICATION

All units are factory programmed to the below specifications. Alteration should only be done by a factory trained technician or after consultation with one of our technical representatives if you have any questions please call **1-866-874-2532**.

Specifications	HTO-100
Salt Used - Per Regeneration	6.0 lbs
Water Used - Regeneration	86.4 gal
Hardness Removal - Grains	25,000
Tank #1 Carbon Quantity (ft3)	1.0 ft
Tank #2 Resin Quantity (ft3)	1.0 ft
Tank Size	9x48
Tank Jacket / Media Loaded	Yes
Brine Tank (Inches)	BTR 18.1 x 34.5 BTS 15.0"x34.7
Salt Storage Capacity	BTS 240 lbs BTR 270 lbs
Flow Rate @ 15 psi Pressure Drop	7.2 gpm
Flow Rate @ 25 psi Pressure Drop	10.0 gpm
Back Wash Flow Rate	4.0 gpm
Shipping Weight	154 lbs
Regeneration Type	Up Flow
Plumbing Connections	HTO Model 1" Straight NPT. 785 Model 3/4" 90° Elbows & 1" Straight NPT
Resin Type	Aquafine 8% cation exchange resin
Carbon Type	Catalytic Carbon
Electrical Requirements	Input 120V 60 Hz - Output 12V 650mA
Water Temperature	40°F and 110°F (4°C - 43°C)
Water Pressure	Min. 30 - Max. 125 psi

Working Temperature: This unit must be operated at temperatures between 40°F and 110°F (4°C - 43°C).

Working Pressure: This water softener must be operated on pressures between 30 psi to 125 psi. If the water pressure is higher than 125 PSI, use a pressure reducing valve in the water supply line to the softener.

Voltage = 120V / 60 Hz

Pipe Size = 3/4" and 1"

- At the stated service flow rates, the pressure drop through these devices will not exceed 15 psig.

- The manufacturer reserves the right to make product improvements which may deviate from the specifications and descriptions stated herein, without obligation to change previously manufactured products or to note the change.

* Do not use water that is microbiologically unsafe without adequate disinfection before or after the system.

Peak flow rates intended for intermittent use only (10 minutes or less) and are for residential applications only. Do not use peak flow rate for commercial applications or for a continuous rate when treated water supplies are geothermal heat pump, swimming pool, etc.

For satisfactory operation, the pumping rate of the well system must equal or exceed indicated backwash flow rate.

All units come with plastic bypass

Maximum Iron = 1.5 ppm

Maximum Hydrogen Sulfide = 0.0 ppm

Maximum Manganese = .75 ppm

pH = 6.5 to 8.5

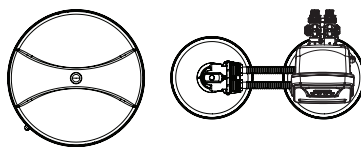

SYSTEM DIMENSIONS

Models	A (Inches)	B (Inches)
HTO-100	58	9

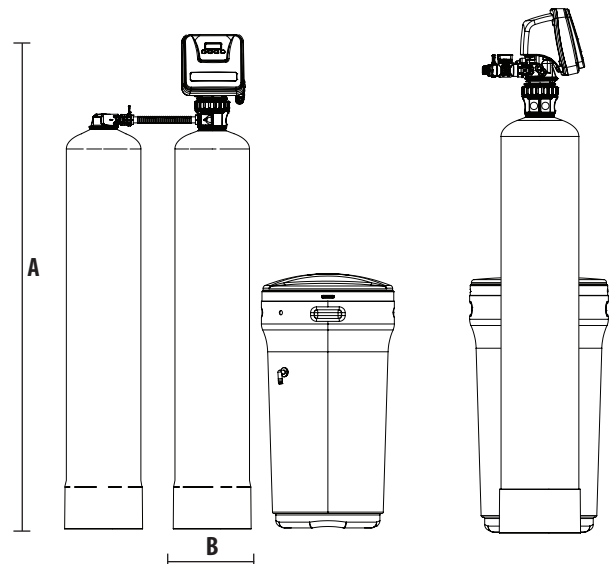

BRINE TANK DIMENSIONS

Model	Color	Liquid Volume		Tank Dimensions (inches)	5 Pack Carton Dimensions (inches)	Salt Capacity		5 Pack Carton Shipping Weight	
		US Gal	Liters	L x W x H	L x W x H	Lbs	Kg	Lbs	Kg
Brine Tanks									
BTR-100	Blue	29.5	111.5	18.1 x 34.7	18.9 x 18.9 x 65.6	270.0	122.2	52.8	23.9

* All brine tanks come with salt grid, safety float and brine well

BTR100

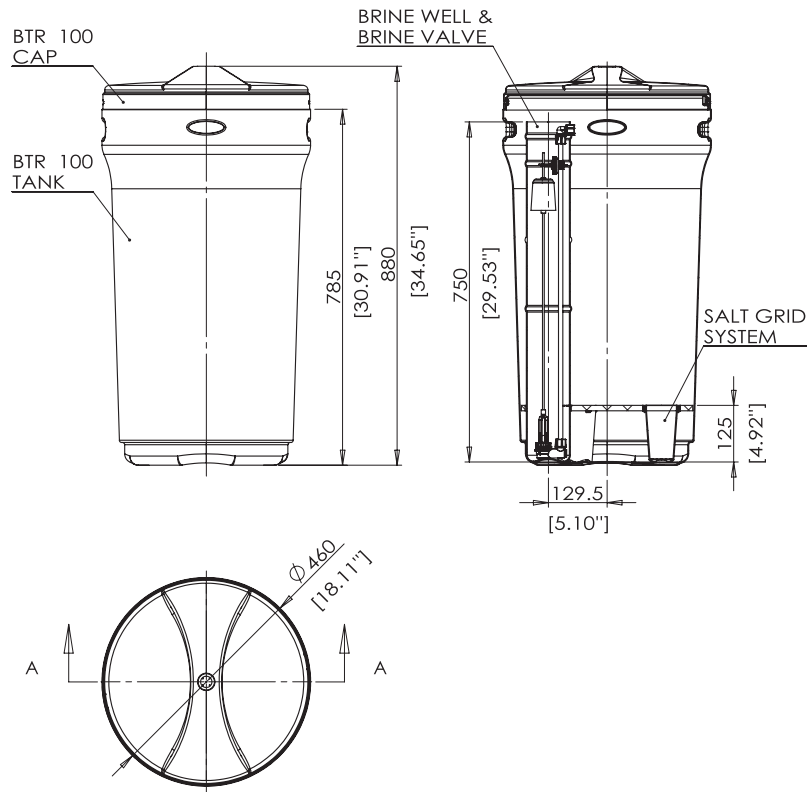

UNPACKING / INSPECTION

Be sure to check the entire unit for any shipping damage or parts loss. Also note damage to the shipping cartons. Contact the transportation company for all damage and loss claims. The manufacturer is not responsible for damages in transit.

Small parts, needed to install the filter, are in a parts box. To avoid loss of the small parts, keep them in the parts bag until you are ready to use them.

What is included in the box?

1. Control Valve
2. Tank 1 c/w Parallel Adaptor
3. Parts Box
4. Owners Manual
5. Parts Bag
6. Tank 2 c/ Adaptor
7. Brine Tank

2. Control Valve

There are 7 Red clips. Please check to make sure you have all of them.

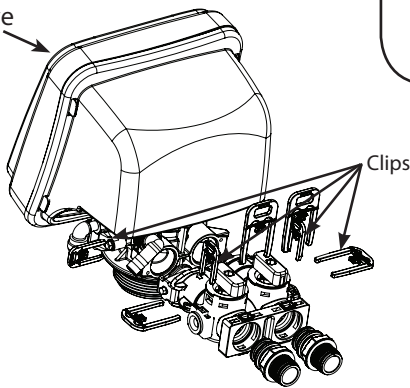

7. Brine Tank

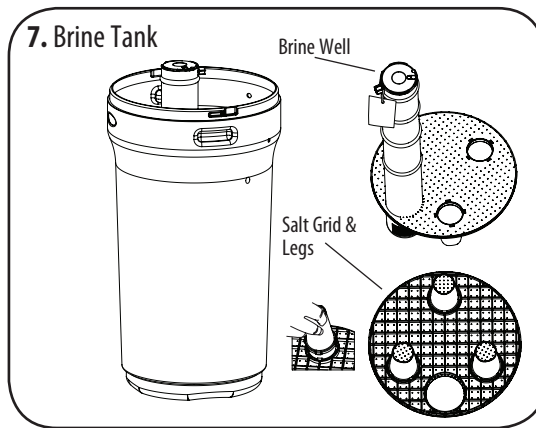

1. Control Valve

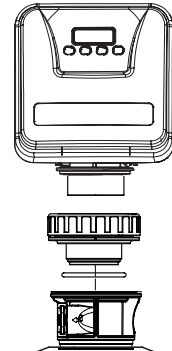

Parallel Adaptor

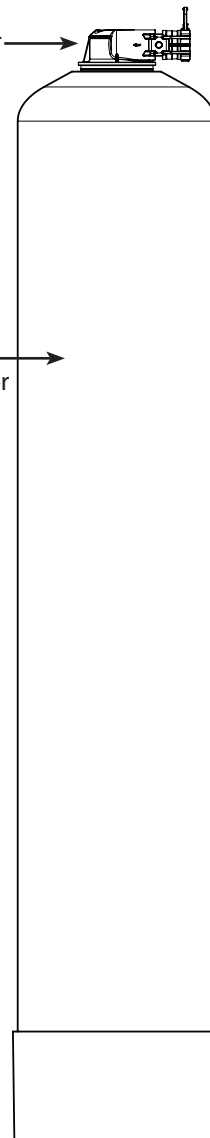

6. Tank 2 c/w Adaptor

2. Tank 1 C/w Parallel Adaptor

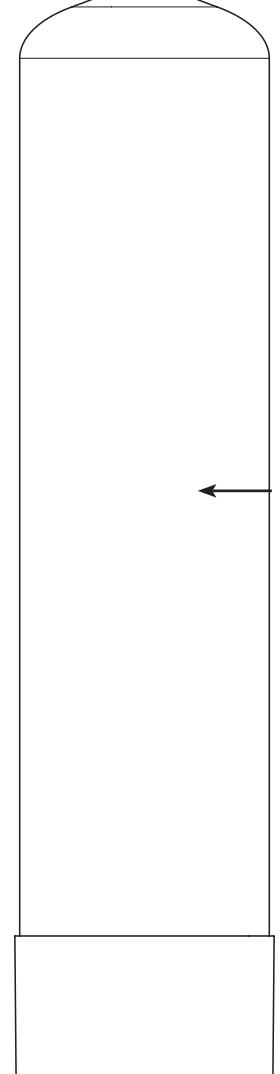

3. Parts Box

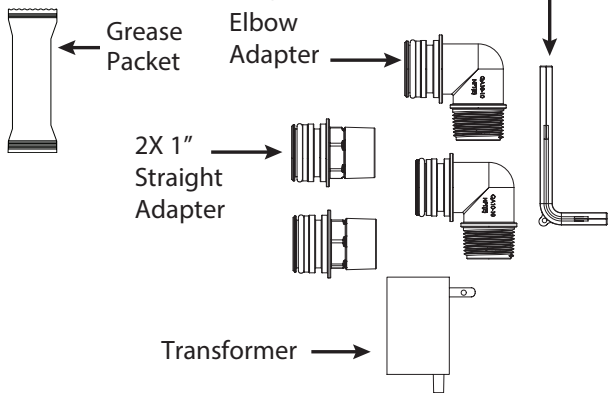

5. Parts Bag

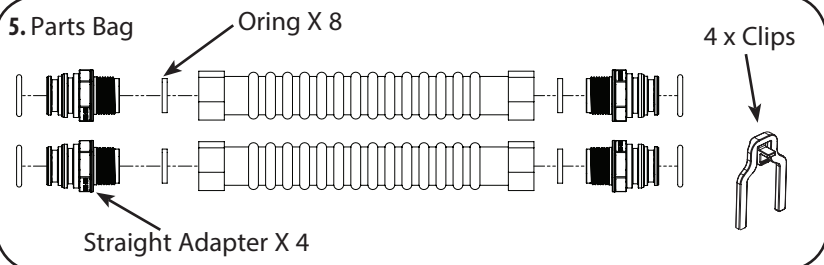

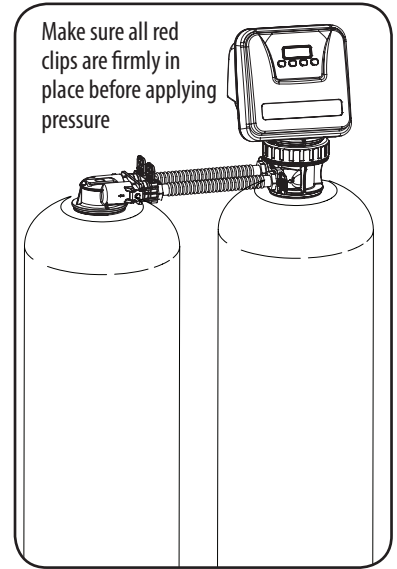
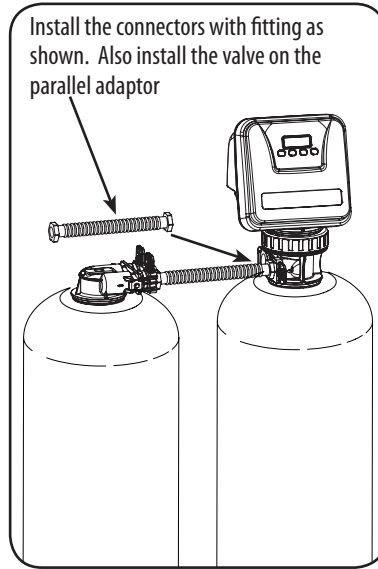
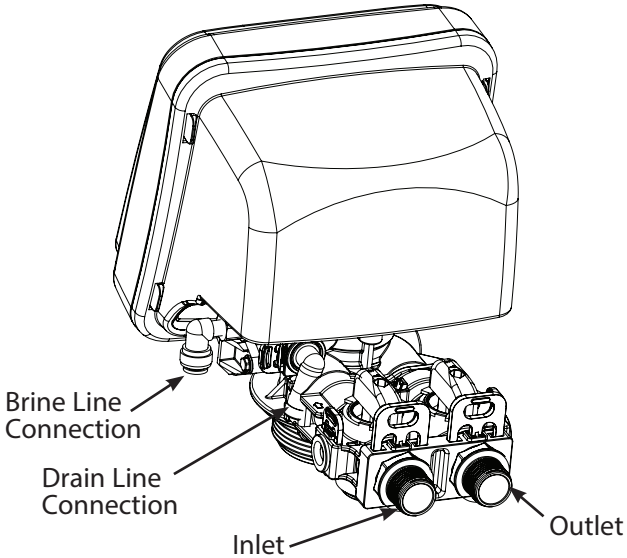
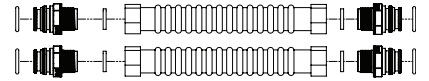

ASSEMBLING BRINE TANK

a) Attach the three brine grid legs to grid plate. The legs will snap on to the tabs of the salt plate making a "click" sound. For square brine tank there are four legs.)

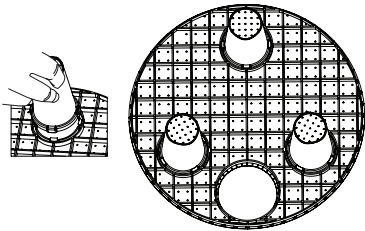

b) Insert the brine well assembly inside the grid plate as well below.

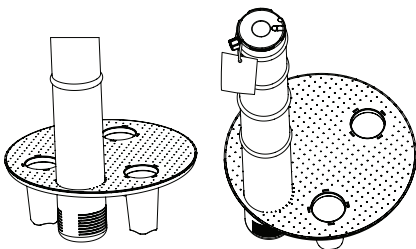

c) Drop the brine grid with brine well inside the brine tank such that the nut fitting faces the hole on the brine tank. Then press the grid evenly inside the brine tank until the brine grid legs touches the bottom of the brine tank.

IMPORTANT: IN ROUND BRINE TANK, IT IS IMPORTANT TO ALIGN THE HANDLE TO THE BRINE WELL AS SHOWN

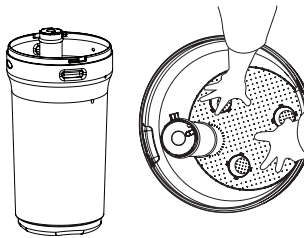

The hole in the brine tank should line up with the brine line as shown for round and square brine tank.

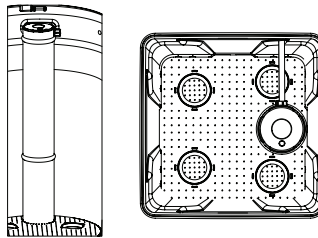

d) Take the brine tube and insert the nut and plastic sleeve as shown below.

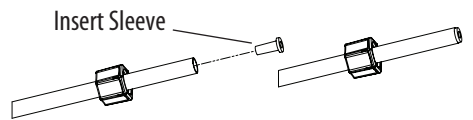

e) Insert the tube in the float assembly elbow and hand tighten the nut. In many cases the brine line already come installed from the factory. Leave the other end of the brine line tube inside the brine tank

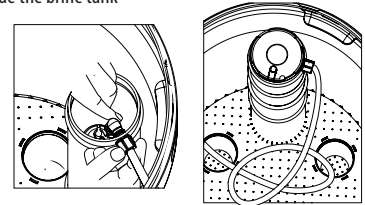

f) For installation of brine tank at the installation site, pull the other end of the brine tube from the hole on the brine tank. The completed assembly is shown below.

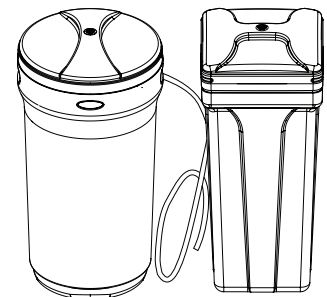

6. Attaching Brine Tubing to the Brine Line of the Valve

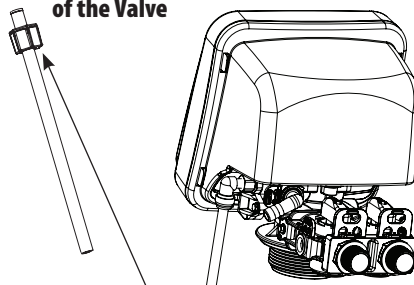

Insert Sleeve inside the Tubing

Check Valve Type and Valve Serial

Check to make sure Valve Type if Downflow (DF) (left Sticker shown below). The right Sticker shows the serial # of the control valve. The middle Sticker is dataplate which provides information of Serial # and Date of Manufacture of complete system. Both Serial # labels are important for troubleshooting.

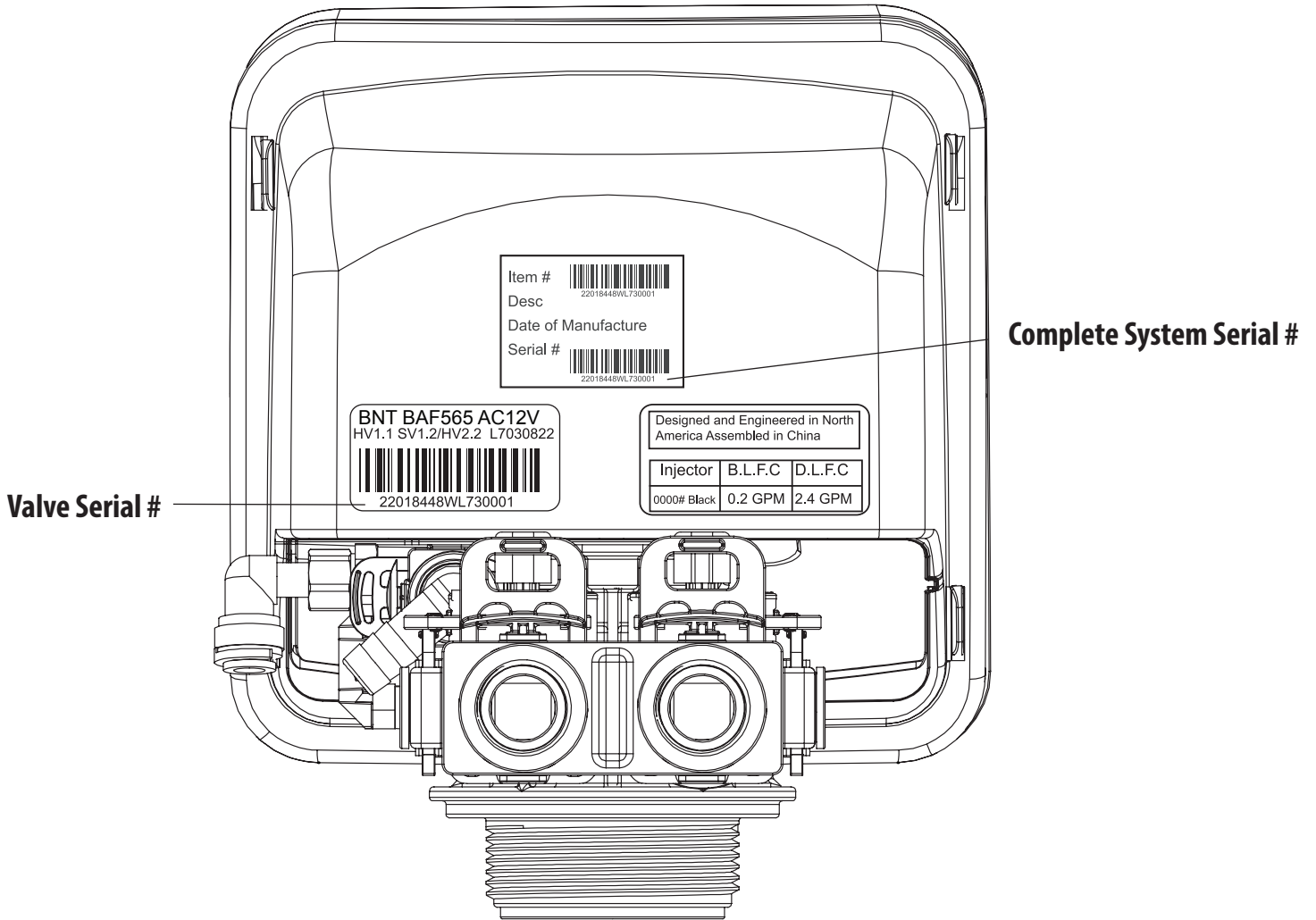

Valve Serial #:

22018448WL730001

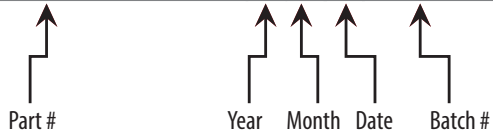

(22018448W): Part #

(L)Year: "M" stand for 2016 year, "L" stand for 2015, "K" stand for 2014, "J" stand for 2013

(7)Month: 1 (Jan) 2(Feb) 3(Mar) 4(April) 5(May) 6(June) 7(July) 8(Aug) 9(Sep) A(Oct) B(Nov) C(Dec)

(3)Date: 1 2 3 4 5 6 7 8 9 A(10) B(11) C(12) D(13) E(14) F(15) G(16) H(17) I(18) J(19) K(20) L(21) M(22) N(23) O(24) P(25) Q(26) R(27) S(28) T(29) U(30) V(31)

(0001): Batch code

BEFORE INSTALLATION

Make sure you have a copy of your most recent water test results. If your water has not been tested previously you can contact your supplier of this product to obtain a water sample bottle to be sent to one of our facilities for a free analysis. **It is important that this product not be installed until you have this information.**

In all cases where metal pipe was originally used and is later interrupted by poly pipe or the Noryl bypass valve or by physical separation, an approved ground clamp with no less than #6 copper conductor must be used for continuity, to maintain proper metallic pipe bonding.

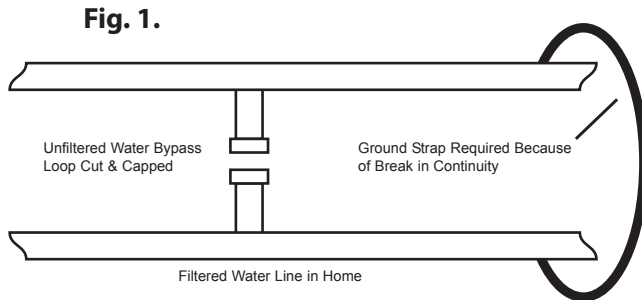

Inspecting and Handling Your HTO Filter*

Inspect the equipment for any shipping damage. If damaged, notify the transportation company and request a damage inspection. Damage to cartons should also be noted.

Handle the filter unit with care. Damage can result if it is dropped or set on sharp, uneven projections on the floor.

Do not turn the filter unit upside down.

To Insure this Product Functions Properly:

Your feed water line size to the unit must be a minimum of 3/4 inch with an operating pressure of no less than 30 psi and no more than 125 psi.

MECHANICAL:

Do not use petroleum based lubricants such as petroleum jelly, oils or hydrocarbon based lubricants. Use only 100% silicone lubricants (grease packet provided in parts kit). All plastic connections should be hand tightened only. Teflon tape may be used on connections that do not use an O-ring seal. Do not use pliers or pipe wrenches except where indicated by Nut shape (eg. pipe adapters) All plumbing must be completed according to local codes. Soldering connections should be done before connecting any pieces to the pipe as excessive heat can damage them.

Tools Required for Installation:

NOTE: We recommend installation only be completed by a competent installer or plumbing professional to insure this product is installed in accordance with local plumbing codes.

- ▶ Two adjustable wrenches
- ▶ Additional tools may be required if modification to home plumbing is required.
- ▶ Plastic inlet and outlet fittings are included with the filter. To maintain full valve flow, 3/4" or 1" pipes to and from the filter fittings are recommended. You should maintain the same, or larger, pipe size as the water supply pipe, up to the filter inlet and outlet.
- ▶ Use copper, brass, or PEX pipe and fittings.
- ▶ Some codes may also allow PVC plastic pipe.
- ▶ ALWAYS install the included bypass valve, or 3 shut-off valves. Bypass valves let you turn off water to the filter for repairs if needed, but still have water in the house pipes.
- ▶ 5/8" OD drain line is needed for the valve drain. A 10' length of hose is not included with some brands.

NOTE

All government codes and regulations governing the installation of these devices must be observed.



CAUTION!

If the ground from the electrical panel or breaker box to the water meter or underground copper pipe is tied to the copper water lines and these lines are cut during installation of the Noryl bypass valve and/or poly pipe, an approved grounding strap must be used between the two lines that have been cut in order to maintain continuity. The length of the grounding strap will depend upon the number of units being installed and/or the amount of copper pipe being replaced with plastic pipe.

See Fig. 1.

NOTE

Check your local electrical code for the correct clamp and cable size.

NOTE

If a severe loss in water pressure is observed when the filter unit is initially placed in service, the filter tank may have been laid on its side during transit. If this occurs, backwash the filter to "reclassify" the media.

*NOTE

Due to transportation and climatic conditions all connections including the valve to the tank need to be checked at time of installation and tightened if necessary.

PREPARATIONS

- 1. Media Installation (When Necessary).** Models larger than 2.0 CF of media are shipped with separate media in pails or boxes. Models lower than 1.5 CF of media come loaded with media and this step can be skipped for new installation.



The unit should be depressurized before installing or replacing media

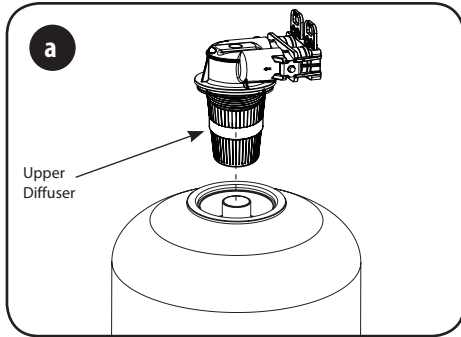

- a)** Remove the adaptor from the mineral tank. Grease the bottom oring of the adaptor with silicone grease provided

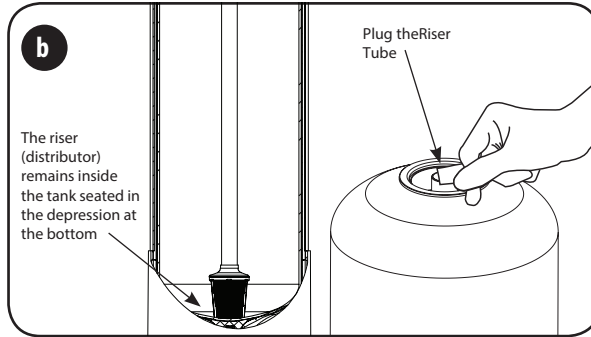
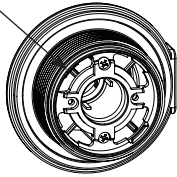

- b)** Temporarily plug the open end of the riser tube to ensure that no resin or gravel falls down into the distribution. The riser (distributor) remains inside the tank seated in the depression at the bottom.

Plug tube with a tape. Remove after media is loaded.

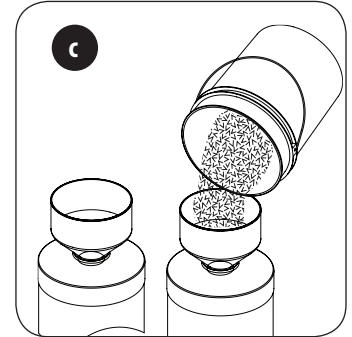

- c)** Fill support bed first. The media will not always spill down inside the tank and may need to be swept inside.

The large funnel (sold separately makes filling the tank easier and neater. (Or an empty 1 gallon or 4 liter container with the bottom cut out makes a good funnel.)

Locate Water Conditioning Equipment Correctly

Select the location of your filter tank with care. Various conditions which contribute to proper location are as follows:

1. Locate as close as possible to the water supply source.
2. Locate as close as possible to a floor or laundry tub drain.
3. Locate in correct relationship to other water conditioning equipment (see Fig. 1, 2, 3 or 4, Page 11 and 12). if closer than 10 feet please install check valve in accordance with local plumbing codes.
4. Conditioners should be located in the supply line before the water heater. Temperatures above 110°F (43°C) will cause damage to conditioners.
5. Do not install a filter or filter in a location where freezing temperatures occur. Freezing may cause permanent damage to this type of equipment and will void the factory warranty.
6. Allow sufficient space around the unit for easy servicing.
7. Keep the filter out of direct sunlight. The sun's heat may soften and distort plastic parts.

NOTE

Never make a direct connection into a waste drain. A physical air gap of at least 1.5" should be used to avoid bacteria and wastewater travelling back through the drain line into the softener.

NOTE

The unit is not ready for service until you complete the start-up instructions, page 15.

Make sure both brass and plastic nuts are tightened well

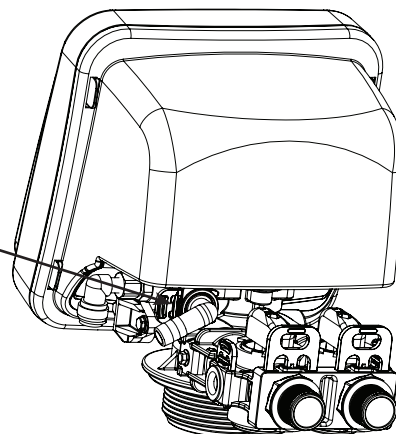

INSTALLATION STEPS

1. Determine the best location for your water filter, bearing in mind the location of your water supply lines, drain line and 120 volt AC electrical outlet. Subjecting the filter to freezing or temperatures above 43°C (110°F) will void the warranty.

Please notice the inlet and outlet labels on the valve as shown here to determine the position of the equipment:

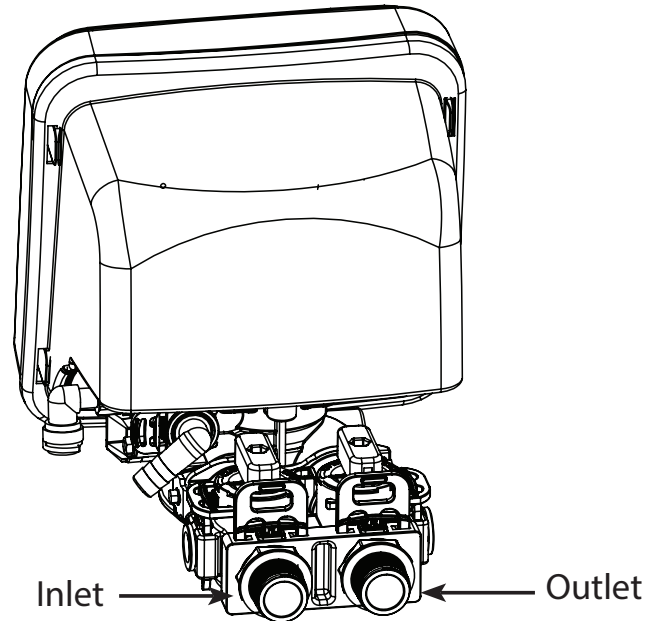

Facts to Remember When Planning Your Installation

1. All installation procedures must conform to local and state or provincial plumbing codes.
2. Outside faucets used to water lawns and gardens should not supply untreated water, replace untreated water with feed water to the unit. If necessary to do this please install check valve, see page 14. A new water line is often required to be connected to supply untreated water to the inlet of the water filter and to the outside faucets.
3. Make sure the bypass is attached well to the control valve. Connect the straight or elbow connectors to the bypass with red clips. Connect the inlet and outlet of the water filter to the plumbing of the house. The control valve must not be submitted to temperatures above 43°C (110°F). When sweat fittings are used, to avoid damaging the control valve, solder the threaded copper adapters to the copper pipe and then, using Teflon tape, screw the assembly into the bypass valve.
Do not use pipe thread compound as it may attack the material in the valve body.
4. Apply Teflon Tape and Orings to the fittings
5. Connect Filter to the house plumbing. Any solder joints near the valve must be done before connecting any piping to the valve. Always leave at least 6" (152 mm) between the valve and joints when soldering pipes that are connected to the valve. Failure to do this could cause damage to the valve.
6. **Drain Line connection:** Using Teflon tape, screw the 1/2" hose barb and attach oring into the drain port in the valve. Attach 1/2" drain hose (Supplied with some models and brands) to the hose barb and tighten securely with a hose clamp (Supplied with some models and brands). Run the drain line to a floor drain or a laundry drain. Complete any necessary plumbing.
7. Using the Allen Key (included), place the unit in the bypass position. Slowly turn on the main water supply. At the nearest cold treated water tap nearby remove the faucet screen, open the faucet and let water run a few minutes or until the system is free of any air or foreign material resulting from the plumbing work.
8. Make sure there are no leaks in the plumbing system before proceeding. Close the water tap when water runs clean.
9. Open the brine tank / cabinet salt lid and add water until there is approximately 3" (75 mm) of water in the tank. Do not add salt to the brine tank at this time.

NOTE

If the plumbing system is used as the ground leg of the electric supply, continuity should be maintained by installing ground straps around any nonconductive plastic piping used in installation.

NOTE

Before starting installation, read page 16, Plumbing System Clean-Up, for instructions on some procedures that may need to be performed first.

INSTALLATION

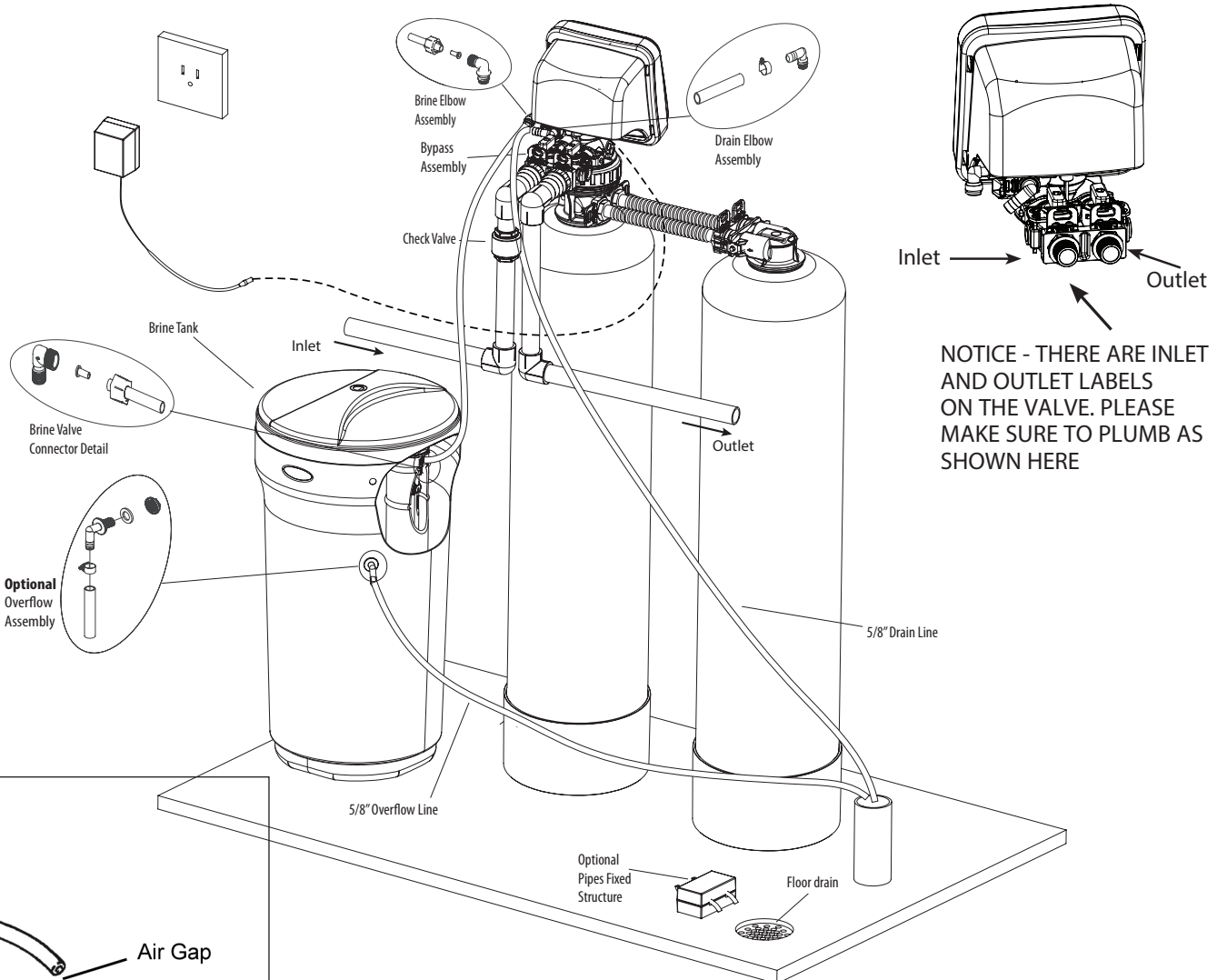
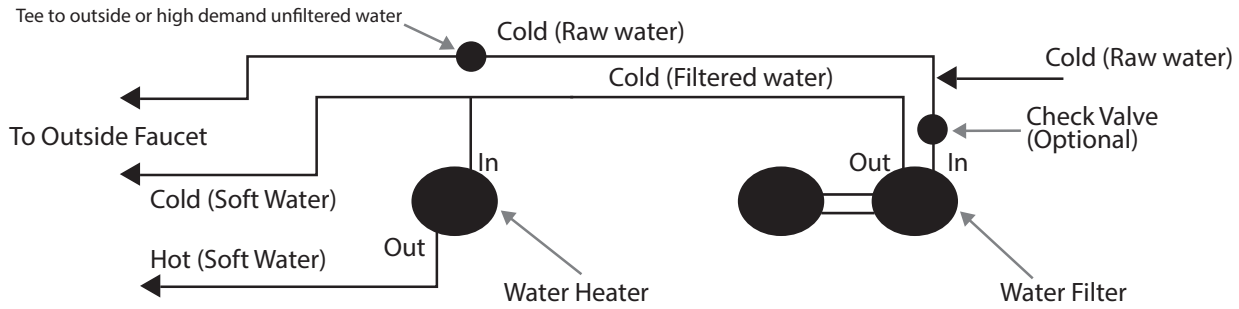

NOTICE - THERE ARE INLET AND OUTLET LABELS ON THE VALVE. PLEASE MAKE SURE TO PLUMB AS SHOWN HERE

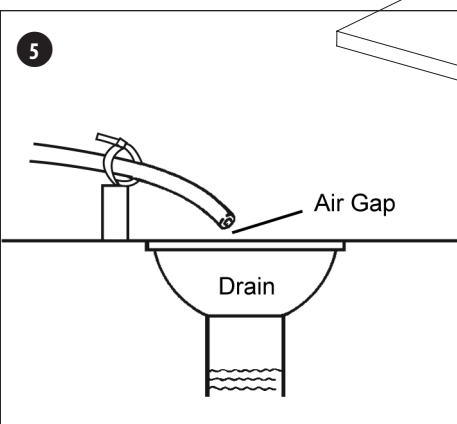

NOTE
Waste connections or drain outlet shall be designed and constructed to provide for connection to the sanitary waste system through an air-gap of 2 pipe diameters or 1 inch (22 mm) whichever is larger.

CAUTION!
Never insert drain line directly into a drain, sewer line, or trap. Always allow an air gap between the drain line and the wastewater to prevent the possibility of sewage being back-siphoned into the conditioner.

STARTUP INSTRUCTIONS

1. Connect the Transformer to the Valve

Plug the 12-volt transformer into a 120 VAC 60 Hz outlet.

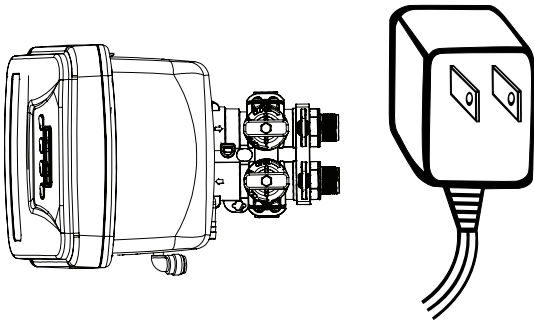

2. Add Water to Brine Tank

Open the brine tank /cabinet salt lid and add water as per the chart below. Do not add salt to the brine tank at this time.

- BTR-100 - 2.5 US Gallons**
- BTR-145 - 3.25 US Gallons**
- BTR-200 - 5.5 US Gallons**

CAUTION!

FAILURE TO FOLLOW STEP 2 WOULD DEplete THE RESERVE CAPACITY OF RESIN AND RESULT IN HARDNESS LEAKAGE. IN CASE STEP 2 IS MISSED, THEN SOFTENER SHOULD BE REGENERATED TWICE OR THRICE BACK TO BACK TO RESTORE THE RESERVE CAPACITY OF RESIN

1. Open the inlet on the bypass valve slowly and allow water to enter the unit. (The outlet of the bypass should remain closed to prevent any fines or debris from entering the plumbing system. Allow all air to escape from the unit before turning the water on fully then allow water to run to drain for 3-4 minutes.
2. Unplug the power cord from the power supply, open inlet. Check the drain line flow. Allow the water to run for 30 minutes, or until all media fines are backwashed from the unit
3. Plug in the valve and advance to the SERVICE position. Open the outlet valve on the bypass, then slowly open the nearest treated water faucet and allow the water to run until clear, close the tap and replace the faucet screen.
4. The Valve is already programmed from factory. Please set up date and time of day and feedwater hardness as shown below:

3. Power and Program Valve

Key Pad Configuration:



1. If screen is locked, press "MENU" for 3 seconds to unlock. Press "MENU" again to enter level one programming mode and adjust **CURRENT TIME**.
2. Press "SET/REGEN" to adjust hours. When you have entered the change value mode, the cursor will blink. Press "UP or DOWN" arrows to change the hour values. Press "SET/REGEN" again to accept the hour value and advance to change the minutes value. Press "UP or DOWN" arrows to change the minute values. Press "SET/REGEN" again to accept the minute values and advance to adjust the AM/PM values. Press "UP or DOWN" to change the AM/PM value. Press "SET/REGEN" again to accept the AM/PM value and exit. When you have exited the change value mode, the cursor will stop flashing.

Setting Current Date

1. Press "DOWN" to advance to CURRENT DATE.
2. Press the "SET/REGEN" to change the value. Press "UP or DOWN" to change the values.

Setting Number of People

1. Press "DOWN" to advance to to NUMBER OF PEOPLE.
2. Press the "SET/REGEN" to change the value. Press "UP or DOWN" arrows to change the values.

Setting Water Hardness

1. Press "DOWN" to advance to **WATER HARDNESS**.
2. Press the "SET/REGEN" to change the value. Press "UP or DOWN" arrows to change the values.

Setting Vacation Mode

1. Press "DOWN" to advance to **VACATION MODE**. Select **NO**.
2. Press the "SET/REGEN" to change the value. Press "UP or DOWN" arrows to change the values.

Programming Flow Chart

Press MENU Key. For Value Adjustment, Press SET/REGEN Key and change the values using UP and DOWN Key

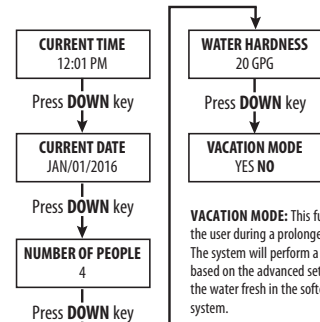

VACATION MODE: This function may be activated by the user during a prolonged absence such as vacation. The system will perform a brief backwash and rinse based on the advanced setting. The purpose is to keep the water fresh in the softener tank and plumbing system.

Screen Display

Familiarize with Button Configuration:

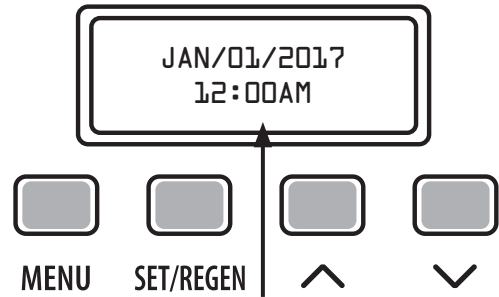

The controller will show the following on the screen - Time, Date and number of Days Remaining for Regeneration.

When power is supplied to the control, the screen may display "INITIALIZING WAIT PLEASE" while it finds the service position.

Initial Manual Regen by pressing **SET/REGEN** button. When in backwash cycle, do not skip the cycle and let all air from the tank escape.

After backwash cycle, the valve will advance to brine draw which needs to be skipped by pressing **SET/REGEN** button.

The valve will now advance to **RINSE CYCLE** which can be skipped. Then valve will advance to refill cycle which should not be skipped. This cycle will let the air our of ejector system of the valve.

STARTUP INSTRUCTIONS (CONTINUED)

3. Manually Regenerate the Valve (Continued)

NOTE All units are factory programmed for the correct size and regeneration cycle alteration should only be done by a factory trained technician or after consultation with one of our technical representatives if you have any questions please call: 1-866-874-2532**

- 3a.** Open the inlet on the bypass valve slightly and very slowly allow water to enter the unit. (If the water enters too quickly it will push the media up into the control valve and get plugged).

Once the unit has filled sufficiently that water is at least equal to the height of the top of the media shut down the water for 15 – 20 minutes for the media bed to soak. Unplug the power cable. After the media bed has soaked for the recommended time continue.

- 3b.** Open the inlet on the bypass valve slowly and allow water to enter the unit. (The outlet of the bypass should remain closed to prevent any fines or debris from entering the plumbing system. Allow all air to escape from the unit before turning the water on fully then allow water to run to drain for 3-4 minutes, or until the water at the drain appears to be clear of any fines.
- 4.** Plug in the valve and the valve will automatically advance to the SERVICE position. Open the outlet valve on the bypass, then slowly open the nearest treated water faucet and allow the water to run until clear, close the tap and replace the faucet screen.

4. Add Salt to the Brine Tank/Cabinet

Put 40 kgs of crystal water softener salt in the brine tank. The unit will automatically fill the water to the correct level when it regenerates.

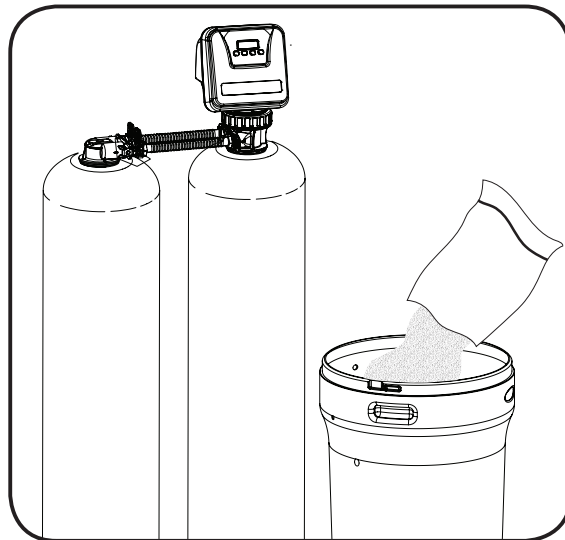

Start up and programming complete. Unit is now operational.

DURING REGENERATION

Automatic Water Bypass

The regeneration cycle lasts approximately 1.5 hours to 3.0 hours depending on the specific model, after which treated water service will be restored. During regeneration, untreated water is automatically bypassed for use in the household. Hot water should be used as little as possible during this time to prevent hard water from filling the water heater.

IMPORTANT: This is why the automatic regeneration is set for sometime during the night and manual regenerations should be performed when little or no water will be used in the household.

Manual Water Bypass

In case of an emergency such as filter maintenance, you can isolate your water filter from the water supply using the bypass valve located at the back of the control. In normal operation the bypass is open with the ON/OFF knobs in line with the INLET and OUTLET pipes. To isolate the filter, simply rotate the knobs clockwise (as indicated by the word BYPASS and arrow) until they lock. You can use your water related fixtures and appliances as the water supply is bypassing the softener. However, the water you use will be hard. To resume treated service, open the bypass valve by rotating the knobs counterclockwise. **Please make sure bypass knobs are completely open otherwise the unfiltered water could bypass through the valve.**

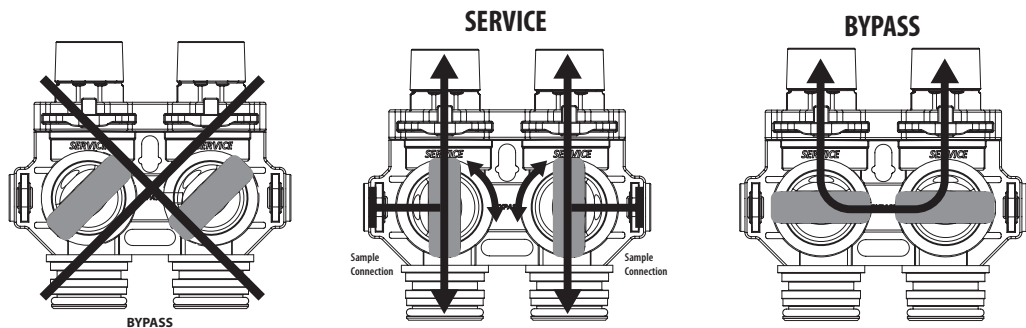

New Sounds

You may notice new sounds as your water softener operates. The regeneration cycle lasts approximately 1.5 hours to 3.0 hours depending on the specific model. During this time, will be able to hear water running intermittently to the drain, depending on proximity of the unit to sleeping area and time of regeneration.

PLUMBING SYSTEM CLEAN-UP

The following procedures are guidelines only but have proven successful in most instances. Under no circumstances should any procedure outlined below be followed if contrary to the appliance manufacturer's instructions. Should there be any questions concerning the advisability of performing a procedure, it is strongly recommended the manufacturer's authorized service outlet be consulted prior to performing the procedure.

Water Heater

If the water heater has been exposed to both iron and hardness for a long period of time, replacement of the heater tank maybe the only practical solution to prevent continued staining originating from this source. After completing the installation of the conditioner, clean the water heater by following these instructions:

1. Shut off energy supply to water heater and close heater inlet water valve.
2. Drain hot water tank completely. Open inlet water valve allowing heater tank to be refilled with iron-free water. Continue flushing until water runs clear to drain.
3. If, after approximately 30 minutes flushing, water does NOT clear, terminate flushing operation. Refill hot water heater with water and pour approximately 1/2 gallon of household bleach into top of heater tank. Allow bleach solution to stand in tank for 20 to 30 minutes. Flush tank

Dishwasher

Consult owners' handbook and follow manufacturer's instructions.

Toilet Flush Tanks

Prior to commencing installation of the filter system, pour 4 to 6 ounces of resin mineral cleaner Pro-Rust Out or other suitable cleaner such as CLR that contains a mild acid into flush tanks and bowls and let stand. When installation is completed, flush toilets several times with conditioned water. If stains or deposits return check that lines are connected to treated water. Repeat procedure until clear. again until water is clear at drain. Turn energy supply on.

NOTE

If water does not clear in approximately 10 minutes, water heater should probably be replaced.



MAINTENANCE INSTRUCTIONS AND SCHEDULE

System Check List

NOTE: Many situations affecting the operation of the product can be diagnosed in only a few minutes. Please review this section before contacting anyone to be sure that there is something wrong with the product and not with the general plumbing system. Please be sure you have reviewed these points before starting up the unit to ensure a successful installation.

1. Check for Proper Installation

- a. Is the inlet line of adequate size and attached to the correct port on the valve?
- b. Is the drain line of adequate diameter? Drain line must be sized to prevent back pressure from reducing backwash flow rate below minimum for the model installed. Typical examples of minimum drain line diameters are:
 - i) 5/8" OD when drain is up to 15 ft from unit and backwash water discharge point is slightly higher than the control valve
 - ii) 3/4" OD when drain is 25 ft away and/or drain is installed overhead
- c. Has the drain line been "kinked"? A kinked drain line must be replaced.
- d. Is the drain line installed in a way that it will freeze in cold weather?

2. Determine Other Uses of Water in Addition to Normal Domestic Purposes

(e.g. geothermal heating or cooling, swimming pool fill, lawn irrigation, farm animal watering, etc.) Have any high demand water uses been added subsequent to the installation of the filter system or overlooked when originally sizing the system? (If a high demand situation exists, resize the system using continuous service flow rate data.)

Service Schedule

- The seals and spacers along with the piston assembly should be inspected/cleaned or replaced every year depending on the inlet water quality and water usage. See inspection and replacement of Piston assembly and seal and spacer kit, page 21, figure 2.
- The injectors should be cleaned/inspected or replaced every year depending on the water quality and use. See Clean Injector Assembly, page 21, figure 3
- SERVICING OF PARALLEL ADAPTOR should be done annually. All connections need to be inspected for leaks, the cross pipes should be removed and inspected for blockage. If there is no evidence of leaking on the adapter no further inspection is required. If additional inspection is required see page 22.
- The media should be replenished or replaced depending of inlet water quality and water consumption. Check with your water treatment expert on the media bed change frequency.
- Maintenance Kit (60010307) should be used for servicing control on an annual basis. The maintenance kit consists of piston assembly, seals and spacers, injectors. See Fig 1. on right.

Maintenance of your new water conditioner requires very little time or effort but it is essential. Regular maintenance will ensure many years of efficient and trouble free operation.

FAILURE TO FOLLOW BASIC MAINTENANCE SCHEDULE WILL RESULT IN THE UNIT FAILING TO OPERATE PROPERLY AND VOID YOUR WARRANTY.

Bridging

Humidity or the wrong type of salt may create a cavity between the water and the salt. This action, known as "bridging", prevents the brine solution from being made, leading to your water supply being hard.

If you suspect salt bridging, carefully pound on the outside of the plastic brine tank or pour some warm water over the salt to break up the bridge. This should always be followed up by allowing the unit to use up any remaining salt and then thoroughly cleaning out the brine tank. Allow four hours to produce a brine solution, then manually regenerate the softener.

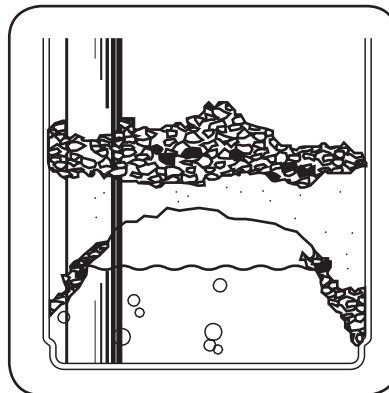

CAUTION!

Liquid brine will irritate eyes, skin and open wounds - gently wash exposed area with fresh water. Keep children away from your water conditioner.

Cleaning of your Brine / Salt tank

Salt tanks will build up sludge (undissolved salt) in the bottom of them that will continue to increase as time goes by. Every 2 - 3 years the salt tank should be cleaned out completely and re started using the original start up instructions.

Never subject your conditioner to freezing, vacuum or to temperatures above 43°C (110°F).

MAINTENANCE INSTRUCTIONS AND SCHEDULE

Checking the Salt Level

Check the salt level monthly. Remove the lid from the cabinet or brine tank, make sure salt level is always above the brine level.

Add Salt to the Brine Tank/Cabinet

Put 40 kgs of crystal water softener salt in the brine tank. The unit will automatically fill the water to the correct level when it regenerates. Use only clean salt labeled for water conditioner use, such as crystal, pellet, nugget, button or solar. The use of rock salt is discouraged because it contains insoluble silt and sand which build up in the brine tank and can cause problems with the system's operation. Add the salt directly to the tank, filling no higher than the top of the brine well.

NOTE :THE WATER LEVEL SHOULD BE BELOW THE SALT LEVEL ALL THE TIME

! CAUTION!

Incorrect start up, water above the salt level, (not enough salt in tank) will both effect the units capacity and result in hardness slippage. Should either of these situations happen or the unit fails to regenerate for any other reason please first correct the problem. Then regenerate the unit manually 2 times in a row to restore the reserve capacity and bring the media bed back up to specification.

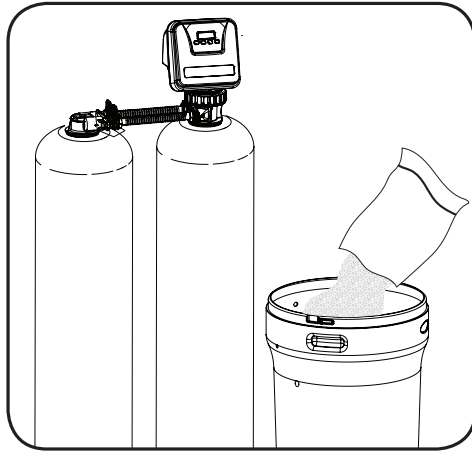
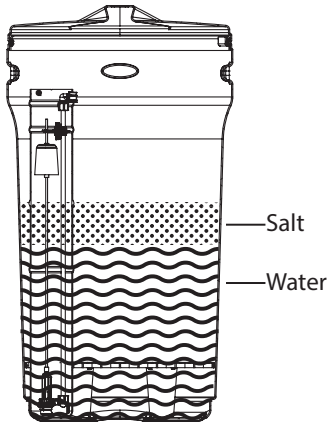

Replacing Media Bed

Frequency of replacing bed is determined by water quality and usage. If you start getting chlorine smell or grey / black coloration of the water from time to time contact your dealer or supplier with your model number to order replacement media.

IMPORTANT WARRANTY AND MAINTENANCE INFORMATION

Please have the information below filled out and available when calling in for parts or warranty:

Model number:
Serial number:
Valve Serial number:
Date installed:

Additional notes:

TIMER REPLACEMENT

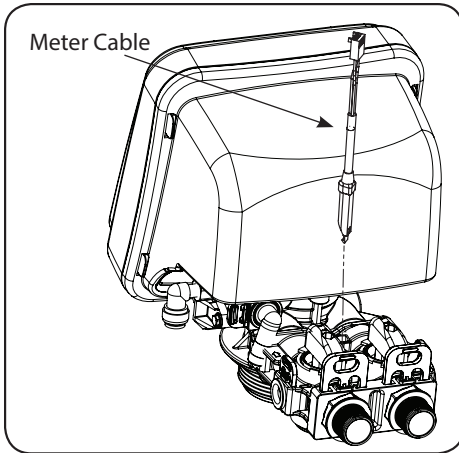

1. Disconnect the meter cable from the meter. (If flow meter is attached)

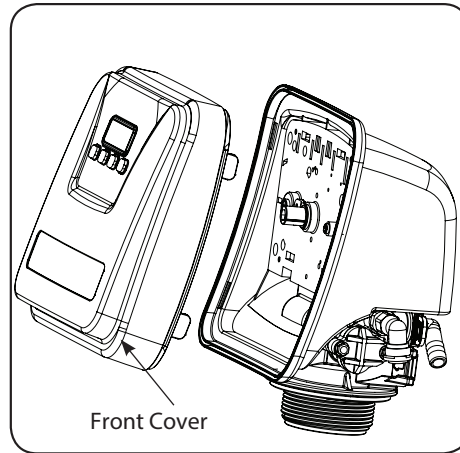

2. Remove the front cover of the valve.

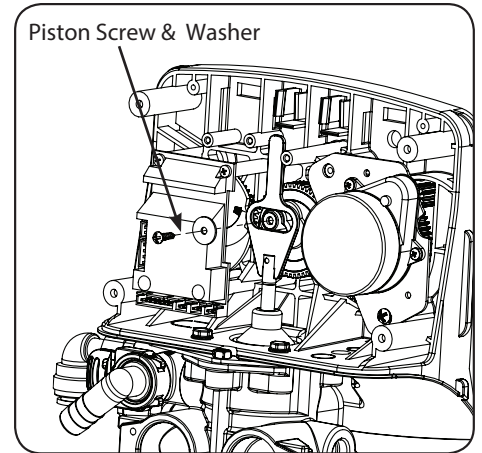

3. Remove the piston screw and washer from the piston rod.

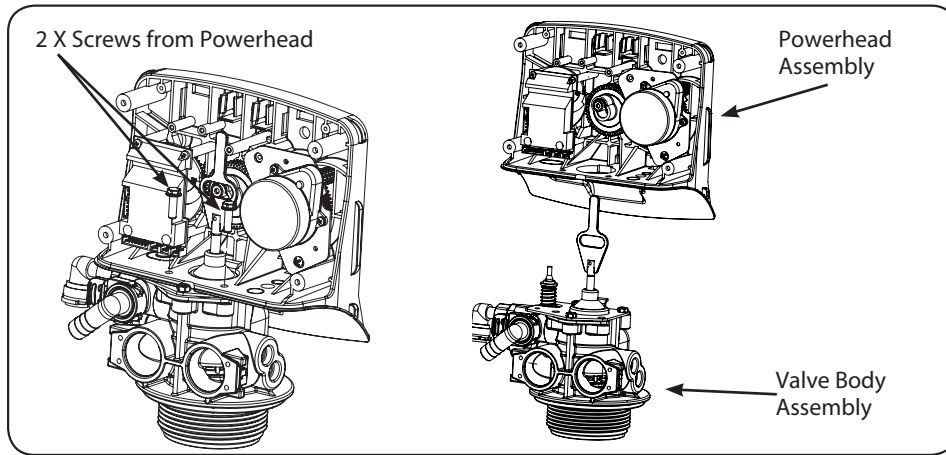

4. Remove the two screws from the powerhead as shown
 5. Lift the powerhead from the valve body assembly
 6. Replace the powerhead by reverse following the steps in this section

PISTON AND/OR BRINE VALVE ASSEMBLY REPLACEMENT

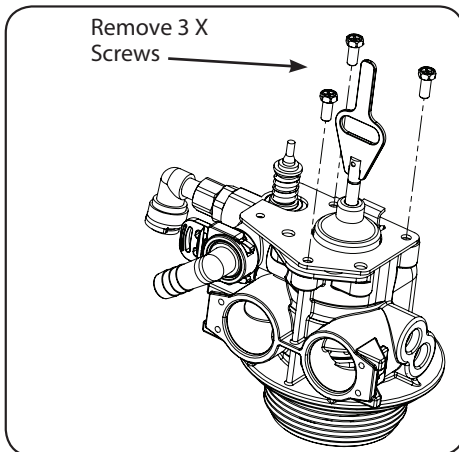

1. Follow steps 1 to 6 of timer /Powerhead replacement.
 2. Remove three screws from the plate on the valve body.

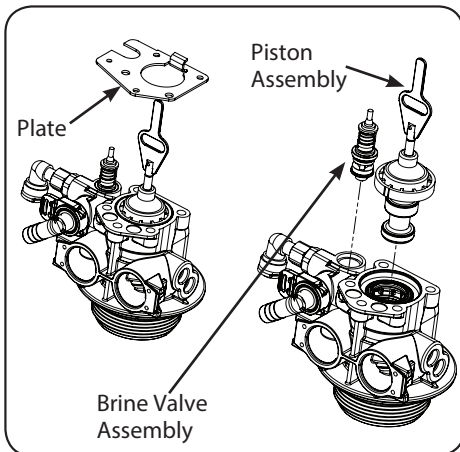

3. Remove the plate from the valve body and pull the Piston Assembly from the valve. The brine valve assembly can also be removed in this stage.
 4. Remove the seal spacer assembly, grease it with silicone lubricant and put back in.

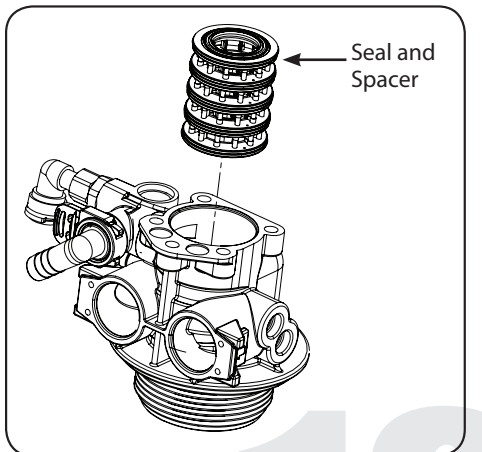

5. Replace piston assembly followed by timer assembly.
 6. Replace the piston assembly and reverse following steps in this section

SERVICING OF PARALLEL ADAPTOR

Tank and Valve Connection Parts

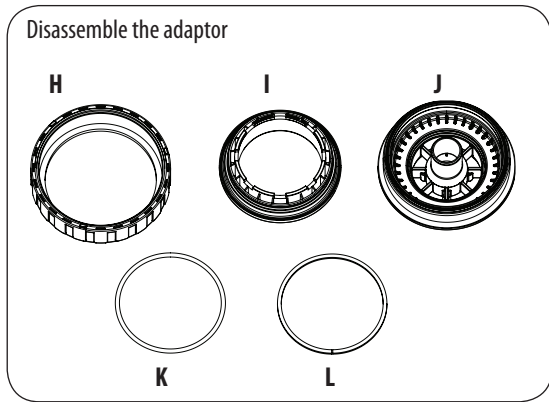
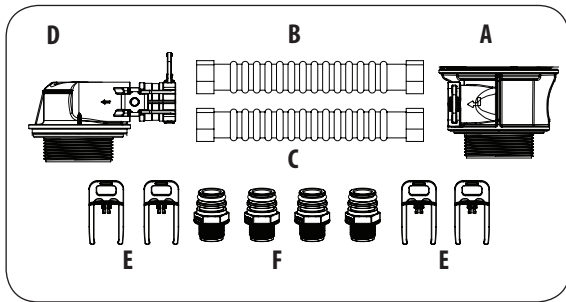

- A. Parallel tank connector w/ O ring
- B. Top pipe connector
- C. Bottom pipe connector
- D. Tank adaptor w/ O ring
- E. Red Clips (4pcs)
- F. 1" x 3 Straight , w O ring
- H. Clamp ring
- I. Valve base
- J. Tank Base
- K. O ring
- L. Retainer ring

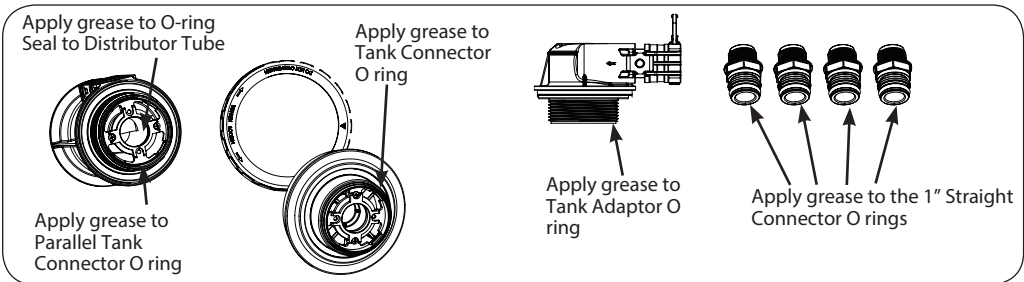

Ensure all O-ring on both tank connectors are properly disassembled and apply a good amount of grease.

NOTE
Full disassembly requires specialty wrenches item's 60010116 and 60010117 and should only be attempted by a qualified service technician. If there is no indication of leaking or fouling of the inlets due to harsh water conditions then there should be no need to disassemble.

METER ASSEMBLY REPLACEMENT

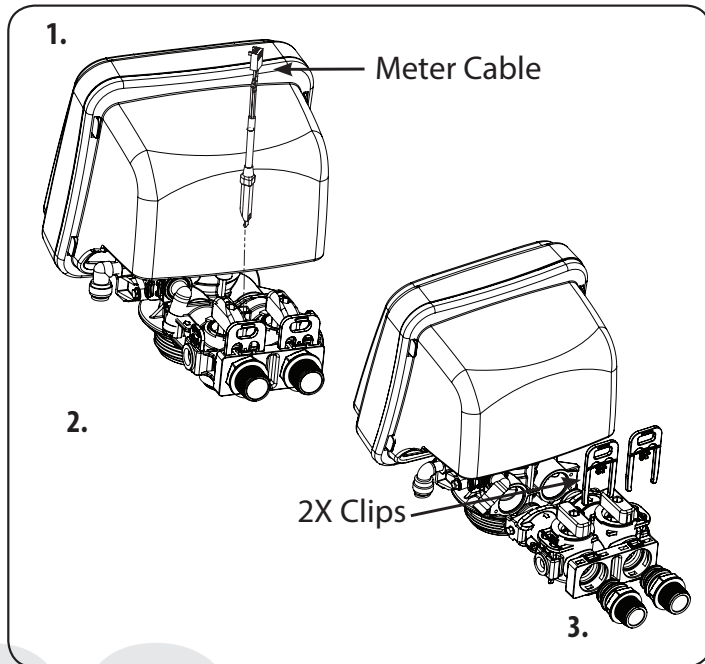

1. Disconnect the meter cable from the meter.
2. Disconnect the valve from bypass by removing clips
3. Remove the coupling adapter from the valve
4. Remove the meter support and then the impeller out from the coupling and clean it
5. Replace meter with the help of special tool and re-assemble the removed components back in the section

CLEAN INJECTOR ASSEMBLY

1. Remove two screws of the injector cap.
2. Pull the Injector Cap Out, Remove the injector assembly, oring and screen, Clean the injectors and replace cap

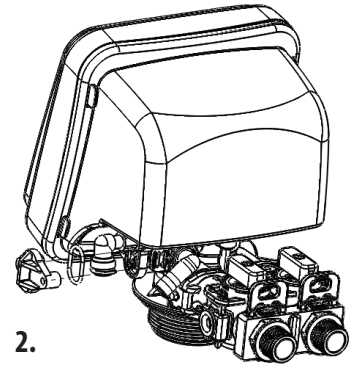
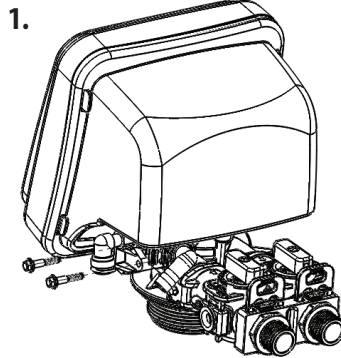

2.

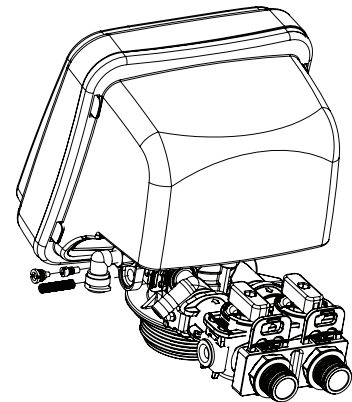

WARNING!

**ELECTRICAL SHOCK
HAZARD! UNPLUG THE UNIT
BEFORE REMOVING THE
COVER OR ACCESSING ANY
INTERNAL CONTROL PARTS**

REPLACE MOTOR

1. Remove Screws from the back of the valve and pull the cover
2. Remove all connections from the circuit board
3. Remove the two screws from the motor. Remove the motor and watch for the pin under the motor.
4. Replace the motor, connections and cover

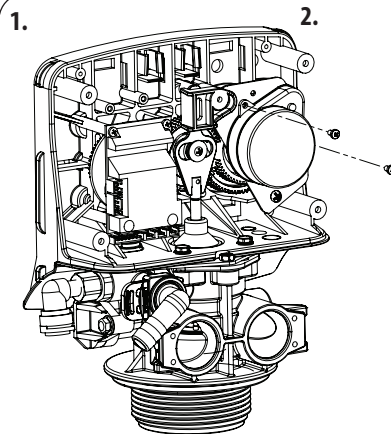

3.

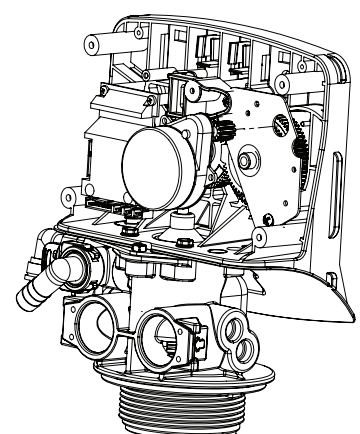

4.

CIRCUIT BOARD REPLACEMENT

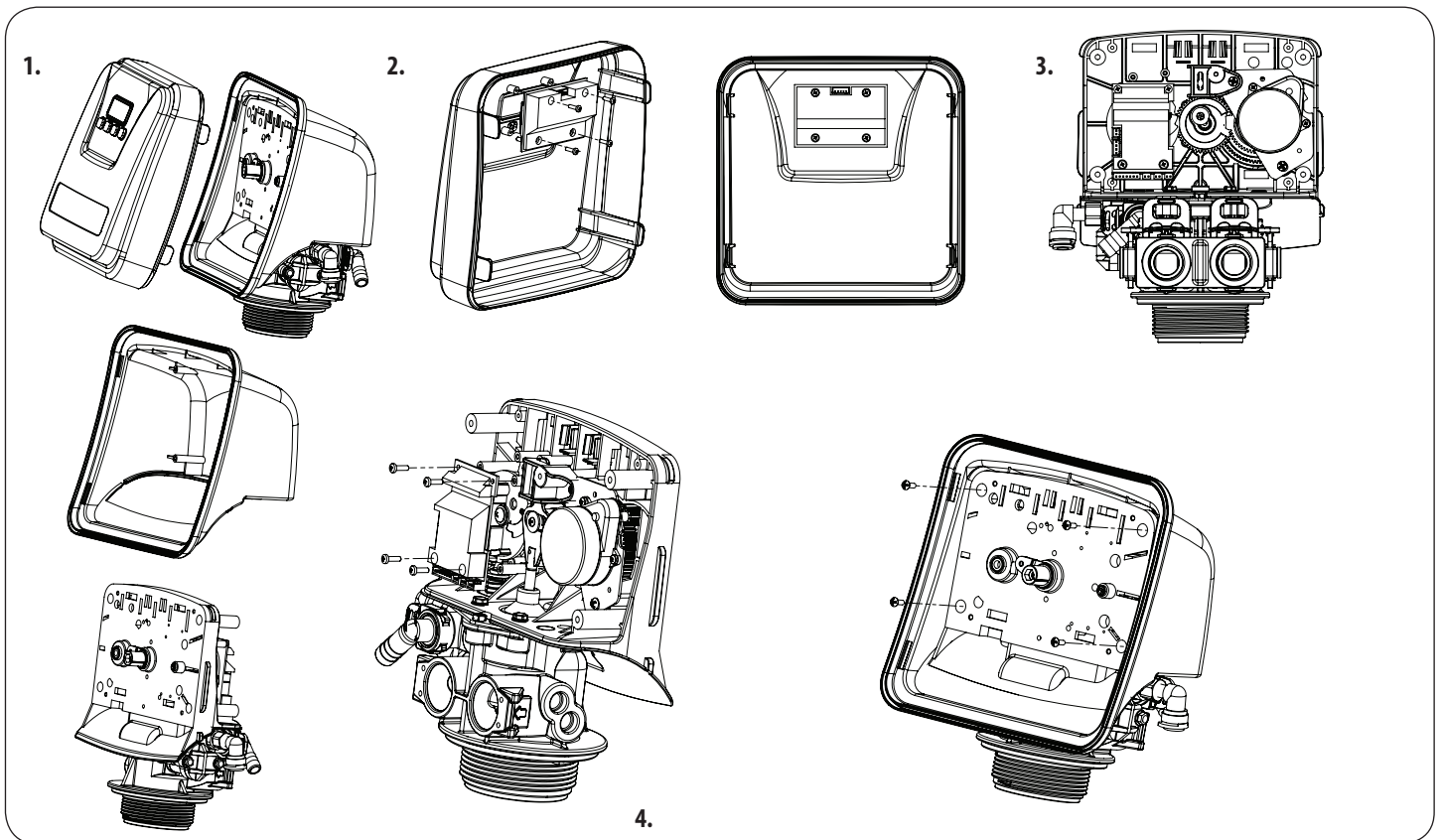

1. Remove the screws from the back of the valve and pull the front cover

2. Remove all connections from the circuit board

3. Remove the four screws from the circuit board and pull it out

REPLACE DRAIN LINE FLOW CONTROL

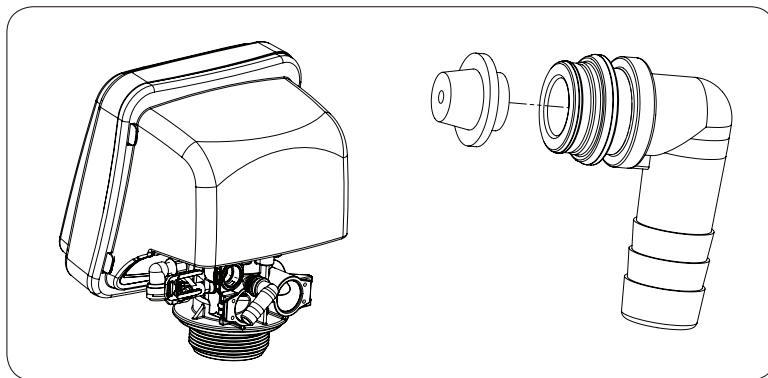

NOTE

Be sure to shut off any bypass line.

AFTER SERVICING

1. Reconnect drain line
2. Return bypass or inlet valve to normal in service position. Water Pressure will automatically build in the filter
3. Check for leaks at all sealed areas. Check Drain seal with the control in the backwash position
4. Plug electrical cord into outlet
5. Set Time of Day and cycle the control valve manually to assure proper function. Make sure control valve is returned to the In Service position

PARTS BREAKDOWN

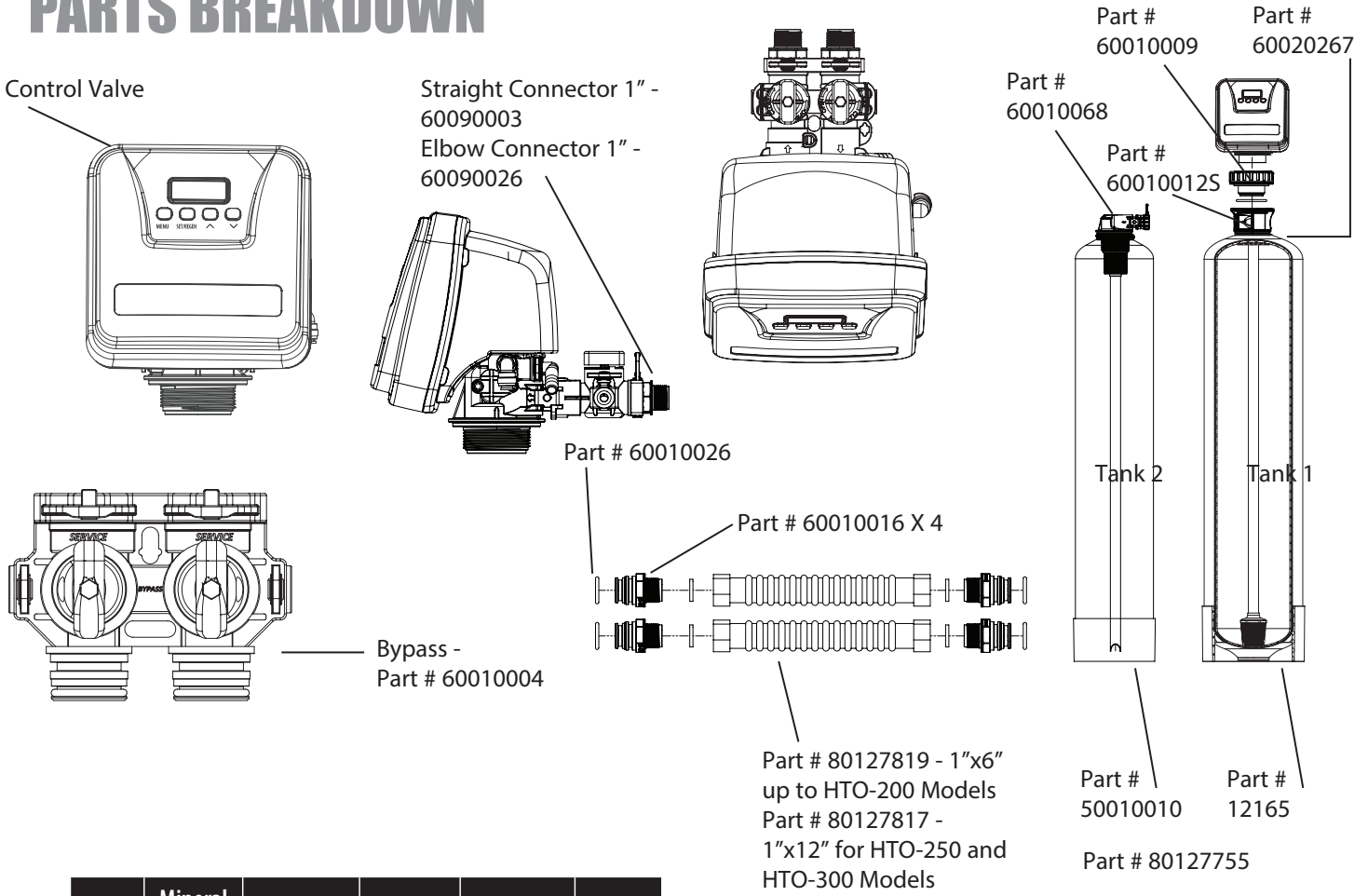

Model	Mineral Tank 1 Size	Tank 1 Media	Tank 2 Media	Distributor#	Valve #
100	9 x 48	CARBON	RESIN	50010005	50010009

TANK ONE CARBON

Model	Mineral Tank Size	Tank # (Natural Color)	Tank # (Black Color)	Tank # (Blue Color)	Distributor#	Valve #	Media Bed #
Softener Downflow (Single Tank)							
100	9 x 48	25010034	25010036	25010035	50010005	50010009	95401

TANK TWO RESIN

Model	Mineral Tank Size	Tank # (Natural Color)	Tank # (Black Color)	Tank # (Blue Color)	Distributor#	Valve #	Media Bed #
Softener Downflow (Single Tank)							
100	9 x 48	25010034	25010036	25010035	50010005	50010009	95601

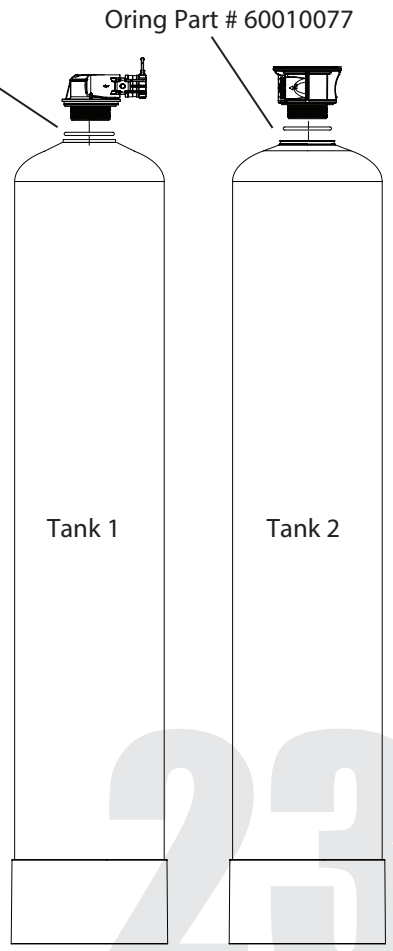

PARTS BREAKDOWN

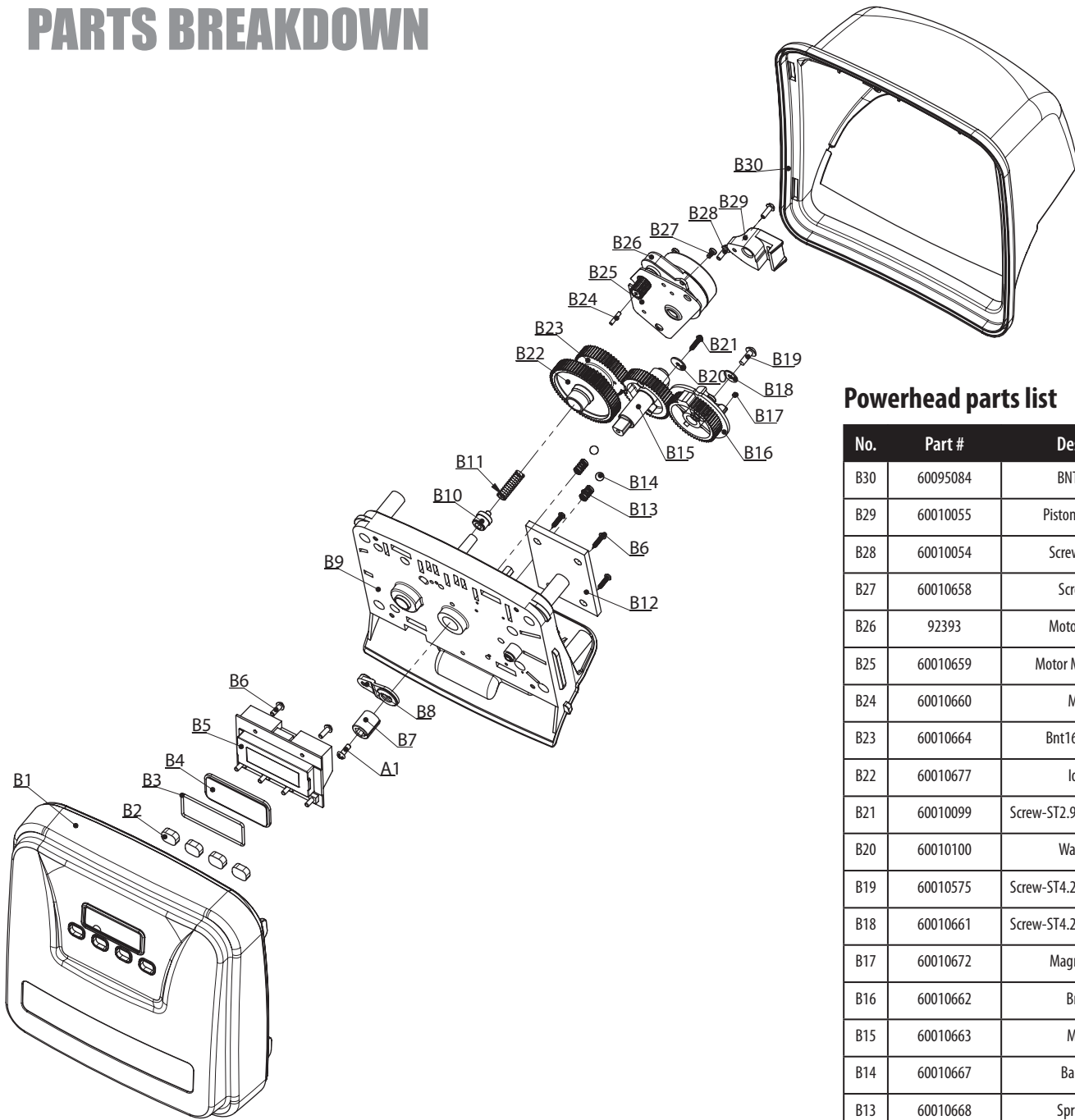

Powerhead parts list

No.	Part #	Description	Qty
B30	60095084	BNT365 Cover	1
B29	60010055	Piston Stem Holder	1
B28	60010054	Screw-ST3.5×13	2
B27	60010658	Screw-M3×5	2
B26	92393	Motor-12v/2rpm	1
B25	60010659	Motor Mounting Plate	1
B24	60010660	Motor Pin	1
B23	60010664	Bnt165 Drive Gear	1
B22	60010677	Idler Gear	1
B21	60010099	Screw-ST2.9×13(Large Wafer)	1
B20	60010100	Washer-3x13	1
B19	60010575	Screw-ST4.2×12(Large Wafer)	1
B18	60010661	Screw-ST4.2×12(Large Wafer)	1
B17	60010672	Magnet-φ3×2.7	1
B16	60010662	Brine Gear	1
B15	60010663	Main Gear	1
B14	60010667	Ball-1/4inch	2
B13	60010668	Spring Detent	2
B12	60010113	BNT85 Main PCB	1
B11	60010103	Spring Idler	1
B10	60010666	Spring Retainer	1
B9	60095085	BNT365 Base	1
B8	60010671	Magnet Holder	1
B7	60010059	Locking Knob	1
B6	60010673	Screw-ST2.9×10	8
B5	60010051	BNT 85 Main PCB	1
B4	60095086	Display Protective Cover	1
B3	60095612	O-ring 40×1.8	1
B2	60010615	BNT465 Button	4
B1	60010056	BNT565 Front Cover	1

Part #	Description	Qty
60010052	Transformer	1
60010105	Transformer Ext. Cable	1
60010115	Meter Cable 165 / 565	1
60010123	Power Cable	1

PARTS BREAKDOWN

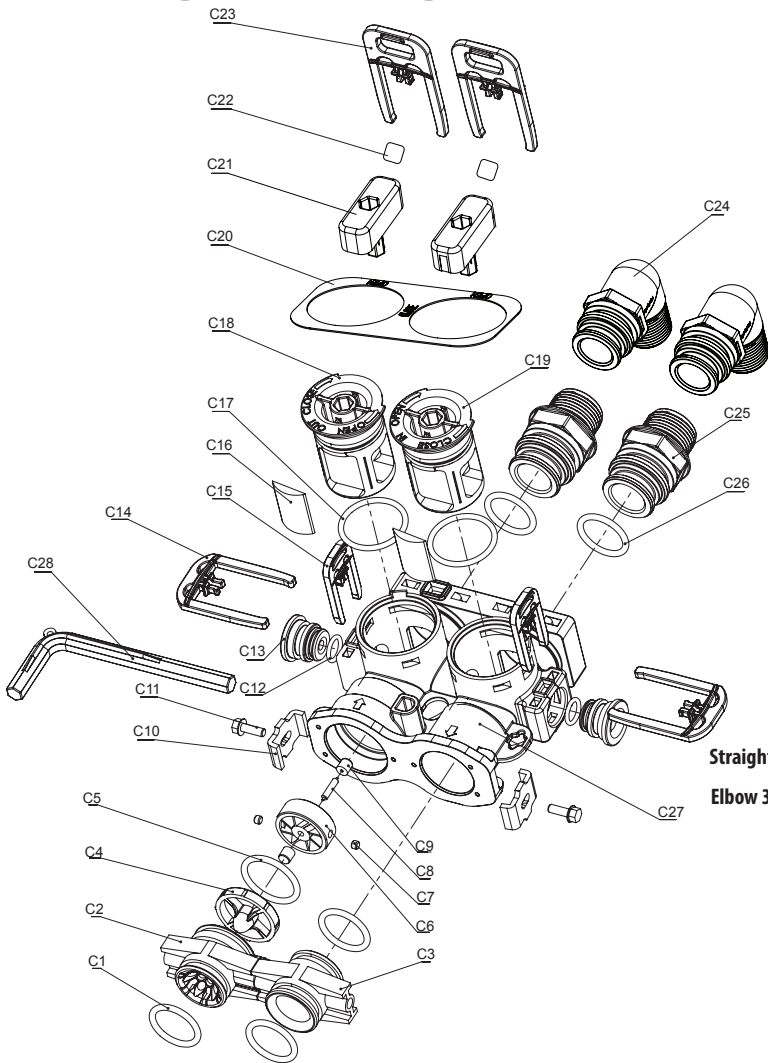

Bypass Parts List

No.	Part # (Water Group)	Part # (Canature)	Description	Qty
C28	60010006	70020007	Bypass Tool	1
C27		05056212	063 Bypass Body	1
C26	60010026	26010143	O-ring on Inlet and Outlet	2
C25	60010019	21319011N	Straight 1" NPT Inlet and Outlet	2
C24	60010023	21319036N	Elbow 3/4" NPT Inlet and Outlet	2
C23	60010025	21709003N	Secure Clip Inlet and Outlet	2
C22	60010740	50040086	Direction Indication Label	2
C21	60010741	05056220	Bypass Knob	2
C20	60010742	61045012	Bypass Indication Plate	1
C19	60095088	05056214	Bypass Shaft(Outlet)	1
C18	60095089	05056213	Bypass Shaft(Inlet)	1
C17	60095614	05030013	O-ring on Shaft	2
C16	60095051	05056149B	Shaft Seal	2
C15	92846	05056155N	Plug Clip	2
C14	60095090	21709004B	Shaft Clip	2
C13	60010209	05056146	Bypass Plug	2
C12	60010044	05056134	O-ring on Plug	2
C11	60010701	13000327	Screw on SS Clip	2
C10	60010046	05056044B	SS Clip	2
C9		05010019	Bush	2
C8		05010079	Impeller Pin	1
C7	60010238	05010078	Magnet	2
C6		05010014	Impeller	1
C5	60010102	26010046	Big O-ring on Connector(Outlet)	1
C4	60010587	05010077	Impeller Support	1
C3	60010079	05056025M	Valve-Bypass Connector(Inlet)	1
C2	60010101	05010083N	Valve-Bypass Connector(Outlet)	1
C1	60010562	05056129	Small O-ring on Connector(Outlet)	3

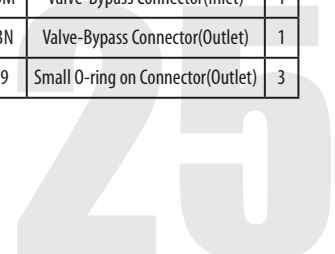

PARTS BREAKDOWN

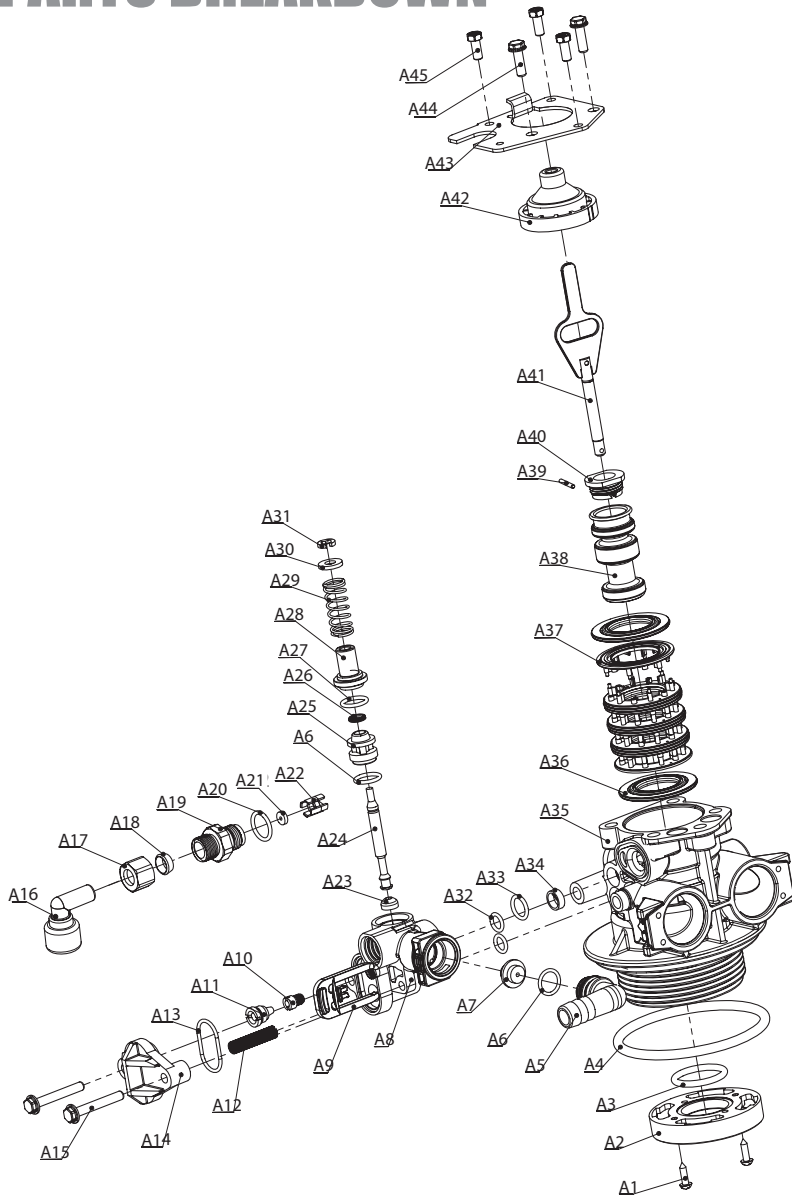

Valve Body Parts List

No.	Part #	Part Description	Qty
A45	60010076	SCREW M5×16	2
A44	60010075	SCREW M5×12	3
A43	60010645	END PLUG RETAINER	1
A42	13446	END PLUG	1
A41	13001	65 PISTON ROD	1
A40	60010646	PISTON RETAINER	1
A39	60010647	PIN	1
A38	60010648	PISTON	1
A37	14241	SPACER	8
A36	13242-02	SEAL	5
A35	13755-1	BNT 65 VALVE BODY	1
A34	60010095	AIR DISPENSER	1
A33	12638	O-RING(11×2)	1
A32	60010094	O-RING(7.8×1.9)	2
A31	60010649	RETAINER RING	1
A30	60010650	INJECTOR WASHER	1
A29	60010651	INJECTOR SPRING	1
A28	60010652	INJECTOR CAP	1
A27	60010185	O-RING(12.5×1.8)	1
A26	60095735	QUAD RING	1
A25	60010653	INJECTOR SPACER	1
A24	60010654	INJECTOR STEM	1
A23	60010655	INJECTOR RUBBER SEAT	1
A22	60010081	BLFC BUTTON RETAINER	1
A21	60010110	BLFC(0.3GPM)	1
A20	60010083	O-RING(14×1.8)	1
A19	13244	COPPER FITTING	1
A18	60010087	BLFC FERRULE	1
A17	60010088	BLFC FITTING NUT	1
A16	60010656	QC BRINE ELBOW	1
A15	60010089	SCREWS M5×30	2
A14	60010090	INJECTOR PLUG	1
A13	60010091	O-RING(23.9×1.8)	1
A12	10227	INJECTOR SCREEN	
A9	60010069	SECURE CLIP-S	1
A8	60010093	INJECTOR BODY	1
A7	60010657	DLFC 3.0GPM	1
A6	60010044	O-RING(12×2)	1
A5	60010229	QC DRAIN LINE ELBOW	1
A4	60010077	O-RING(78.74×5.33)	1
A3	60010080	O-RING(25×3.55)	1
A2	60010599	VALVE BOTTOM CONNECTOR	1
A1	60010574	SCREWS ST3.5×13	2

Item #s For All Injector Assemblies and Brine Line and Drain Line Washers

Part #	Part Description
A21	60010110 BLFC BUTTON #2 0.3GPM A32
60010082*	BLFC BUTTON #2 0.7GPM A32
60010128	BLFC BUTTON 0.2GPM
60010601	INJECTOR SET #0000 BLACK THROAT
60010602	NOZZLE #0000 BLACK THROAT
60010603	INJECTOR SET #000 GREY THROAT
60010604	NOZZLE #000 GREY THROAT
60010605	INJECTOR SET #00 VIOLET THROAT
60010606	NOZZLE #00 VIOLET THROAT
60010607	INJECTOR SET #0 RED THROAT
60010608	NOZZLE #0 RED THROAT
60010609*	INJECTOR SET #1 WHITE THROAT
60010610*	NOZZLE #1 WHITE THROAT
60010611	INJECTOR SET #2 BLUE THROAT
60010612	NOZZLE #2 BLUE THROAT

Part #	Part Description
A10 and A11	60010613 INJECTOR SET #3 YELLOW THROAT
60010614	NOZZLE #3 YELLOW THROAT
60010685	INJECTOR SET #4 GREEN THROAT
60010686	NOZZLE #4 GREEN THROAT
A7	60010131 DLFC #1 1.5GPM
60010132	DLFC #2 2.0GPM
60010133	DLFC #3 2.4GPM
60010135	DLFC #5 3.5GPM
60010041	DLFC #6 4GPM
60010169	DLFC #7 5GPM
60010136	DLFC #A 5.0GPM
60010137	DLFC #B 7.0GPM
60010138	DLFC #C 11.0GPM

* Default

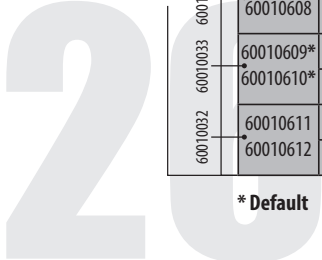

PARTS BREAKDOWN

Tank and Valve Connection PART

No.	Part #	Part Description	Qty
A	60010012	PARALLEL TANK CONNECTOR W/ O RING	1
B	80127756	TOP PIPE CONNECTOR	1
C	80127755	BOTTOM PIPE CONNECTOR	1
D	60010067	TANK ADAPTOR W/ O RING	1
E	60010025	RED CLIPS (4PCS)	4
F	60010026	O RING	1
	60010017	3/4" X 3 STRAIGHT	3
G	60010026	O RING	1
	60010021	3/4" X 1 90 DEGREE	1
H		CLAMP RING	1
I		VALVE BASE	1
J		TANK BASE	1
K	60010073	O-RING (87.5x3.55)	
L		RETAINER RING	

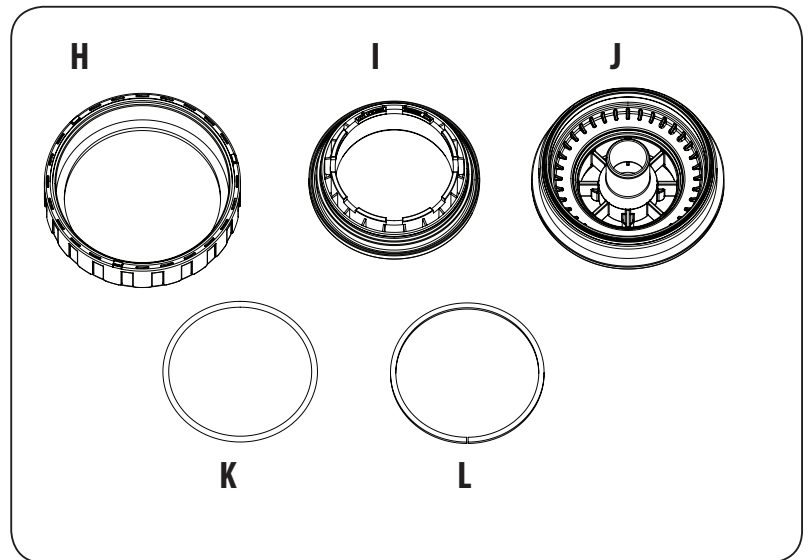
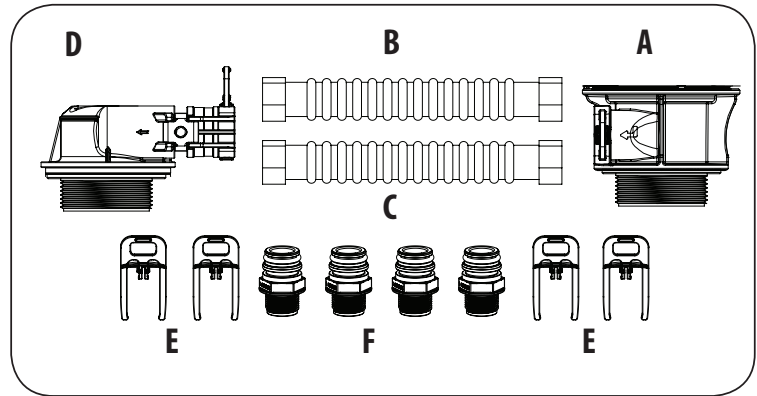

TROUBLE SHOOTING GUIDE

Problem	Possible Solutions
<p>1. CONDITIONER DELIVERS HARD WATER</p> <ul style="list-style-type: none"> A. Bypass valve is open B. No salt in brine tank C. Injector or screen plugged D. Insufficient water flowing into brine tank E. Hot water tank hardness F. Leak at distributor tube G. Internal valve leak H. Flow meter jammed I. Flow meter cable disconnected or not plugged into meter cap J. Improper programming 	<ul style="list-style-type: none"> A. Close bypass valve B. Add salt to brine tank and maintain salt level above water level C. Replace injectors and screen D. Check brine tank fill time and clean brine line flow tank control if plugged E. Make sure distributor tube is not cracked. Check O ring and tube pilot F. Make sure distributor tube is not cracked. Check O ring and tube pilot G. Replace seals and spacers and/or piston H. Remove obstruction from flow meter I. Check meter cable connection to timer and meter cap J. Reprogram the control to the proper regeneration type, inlet water hardness, capacity or flow meter size.
<p>2. CONDITIONER FAILS TO REGENERATE</p> <ul style="list-style-type: none"> A. Electrical service to unit has been interrupted B. Timer is not operating properly C. Defective valve drive motor D. Improper programming 	<ul style="list-style-type: none"> A. Assure permanent electrical service (check fuse, plug, chain or switch) B. Replace timer C. Replace drive motor D. Check programming and reset as needed
<p>3. UNIT USES TOO MUCH SALT</p> <ul style="list-style-type: none"> A. Improper salt setting B. Excessive water in brine tank C. Improper programming 	<ul style="list-style-type: none"> A. Check salt usage and salt setting B. See #7 C. Check programming and reset as needed
<p>4. LOSS OF WATER PRESSURE</p> <ul style="list-style-type: none"> A. Iron build-up in line to water conditioner B. Iron build-up in water conditioner C. Inlet of control plugged due to foreign material broken loose from pipes by recent work done on plumbing system. 	<ul style="list-style-type: none"> A. Clean line to water conditioner B. Clean control and add resin cleaner to resin bed. Increase frequency of regeneration C. Remove piston and clean control
<p>5. LOSS OF RESIN THROUGH DRAIN LINE</p> <ul style="list-style-type: none"> A. Air in water system B. Drain line flow control is too large 	<ul style="list-style-type: none"> A. Assure that well system has proper air eliminator control. Check for dry well condition. B. Ensure drain line flow control is sized
<p>6. IRON IN CONDITIONED WATER</p> <ul style="list-style-type: none"> A. Fouled resin bed B. Iron content exceeds recommended parameters 	<ul style="list-style-type: none"> A. Check backwash, brine draw and brine tank fill. Increase frequency of regeneration. Increase backwash time. B. Add iron removal filter system
<p>7. EXCESSIVE WATER IN BRINE TANK</p> <ul style="list-style-type: none"> A. Plugged drain line flow control B. Brine valve failure C. Improper programming 	<ul style="list-style-type: none"> A. Clean flow control B. Replace brine valve C. Check programming and reset as needed
<p>8. SALT WATER IN SERVICE LINE</p> <ul style="list-style-type: none"> A. Plugged injector system B. Timer not operating properly C. Foreign material in brine valve D. Foreign material in brine line flow control E. Low water pressure F. Improper programming 	<ul style="list-style-type: none"> A. Clean injector and replace screen B. Replace timer C. Clean or replace brine valve D. Clean brine line flow control E. Raise water pressure F. Check programming and reset as needed
<p>9. CONDITIONER FAILS TO DRAW BRINE</p> <ul style="list-style-type: none"> A. Drain line flow control is plugged B. Injector is plugged C. Injector screen is plugged D. Line pressure is too low E. Internal control leak F. Improper programming G. Timer not operating properly 	<ul style="list-style-type: none"> A. Clean drain line flow control B. Clean or replace injectors C. Replace screen D. Increase line pressure (line pressure must be at least 20 psi at all times) E. Change seals and spacers and/or piston assembly F. Check programming and reset as needed G. Replace timer
<p>10. CONTROL CYCLES CONTINUOUSLY</p> <ul style="list-style-type: none"> A. Timer not operating properly B. Faulty hall sensor on circuit 	<ul style="list-style-type: none"> A. Replace timer B. Replace circuit board

TROUBLE SHOOTING GUIDE (CONTINUED)

Problem	Possible Solutions
11. DRAIN FLOWS CONTINUOUSLY A. Foreign material in control B. Internal control leak C. Control valve jammed in brine or backwash position D. Timer motor stopped or jammed teeth E. Timer not operating properly	A. Remove piston assembly and inspect bore. Remove foreign material and check control in various regeneration positions B. Replace seals and/or piston assembly C. Replace piston and seals and spacers D. Replace timer motor and check all gears for missing teeth E. Replace timer
12. Electrical Trouble Shooting: Issue 1: When the controller is plugged, the buzzer beeps and the screen displays "System Error E1" Cause: The wire of micro switch is not plugged or loose.	Check the micro switch and connect the wire well.
13. Electrical Trouble Shooting: Issue 2: The buzzer beeps and the screen displays "System Maintaining E1" Cause: The wire of micro switch is not plugged or loose..	Check the micro switch and connect the wire.
14. Electrical Trouble Shooting: Issue 3: The buzzer beeps and the screen displays "System Error E2" Cause: The motor can not find its right position, micro switch or motor malfunction, automatic circuit protection action.	Check the current of micro switch and motor.
15. Electrical Trouble Shooting: Issue 4: The buzzer beeps and the screen displayed " System Maintaining E2" Cause: The motor can not find its right position.	Replace Motor or PCB.

MASTER PROGRAMMING GUIDE **Below is how the settings are set at factory:**

MASTER PROGRAMMING - 465,565 SERIES																							
Press '^' and 'v' for 8 seconds		PRESS '^' AND 'V'														VALVE SETTINGS							
MODEL	SYSTEM LANGUAGE	VALVE OPERATION	REGEN MODE	REGEN TIME	CAP CALC	REGEN DAYS	GAL	RESIN VOL	SALT SET	Refill	UNIT CAP	RESERV CAP	BACK WASH	BRINE RINSE	RINSE	REFILL	Injector	Injector Color	BLFC Washer	DLFC Washer	DLFC Code	BT Grid EXTs	Upper Cone
HTO-100	ENGLISH	SOFTENER	METER DELAYED	2:00AM	AUTO			1.0CF	6.0LB	0.7	25,000	75 GAL	10	90	15		#1	White	0.7	4	#6		YES

MASTER PROGRAMMING GUIDE

Press **Up** and **Down** Button for 3 seconds

Press **Manual Regen** Button and change value using **Up** and **Down** Buttons

Key Pad Setting

MENU This function is to enter the basic set up information required at the time of installation.

SET/REGEN This function is to initiate an immediate or delayed manual regeneration.

DOWN / UP Increase or decrease the value of the settings while in the programming mode.

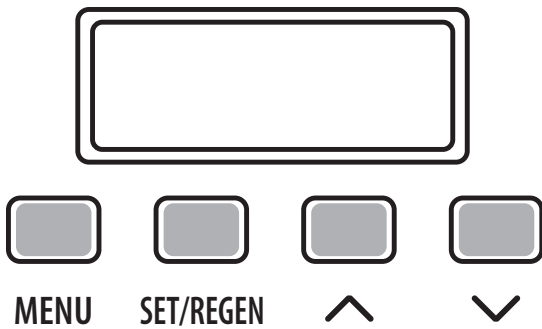

Main Valve Settings

Meter Ratio	5.714
Service Delay	2.0
Backwash Delay	2.0
Brine Delay	2.0
Rinse Delay	2.0
Refill Delay	2.0

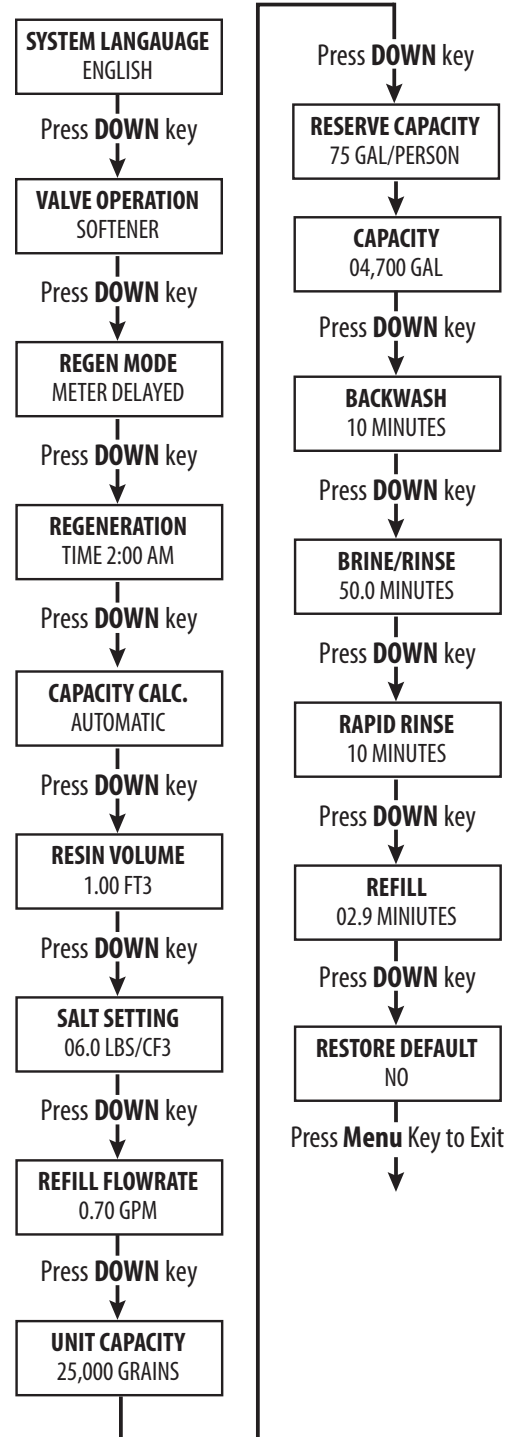

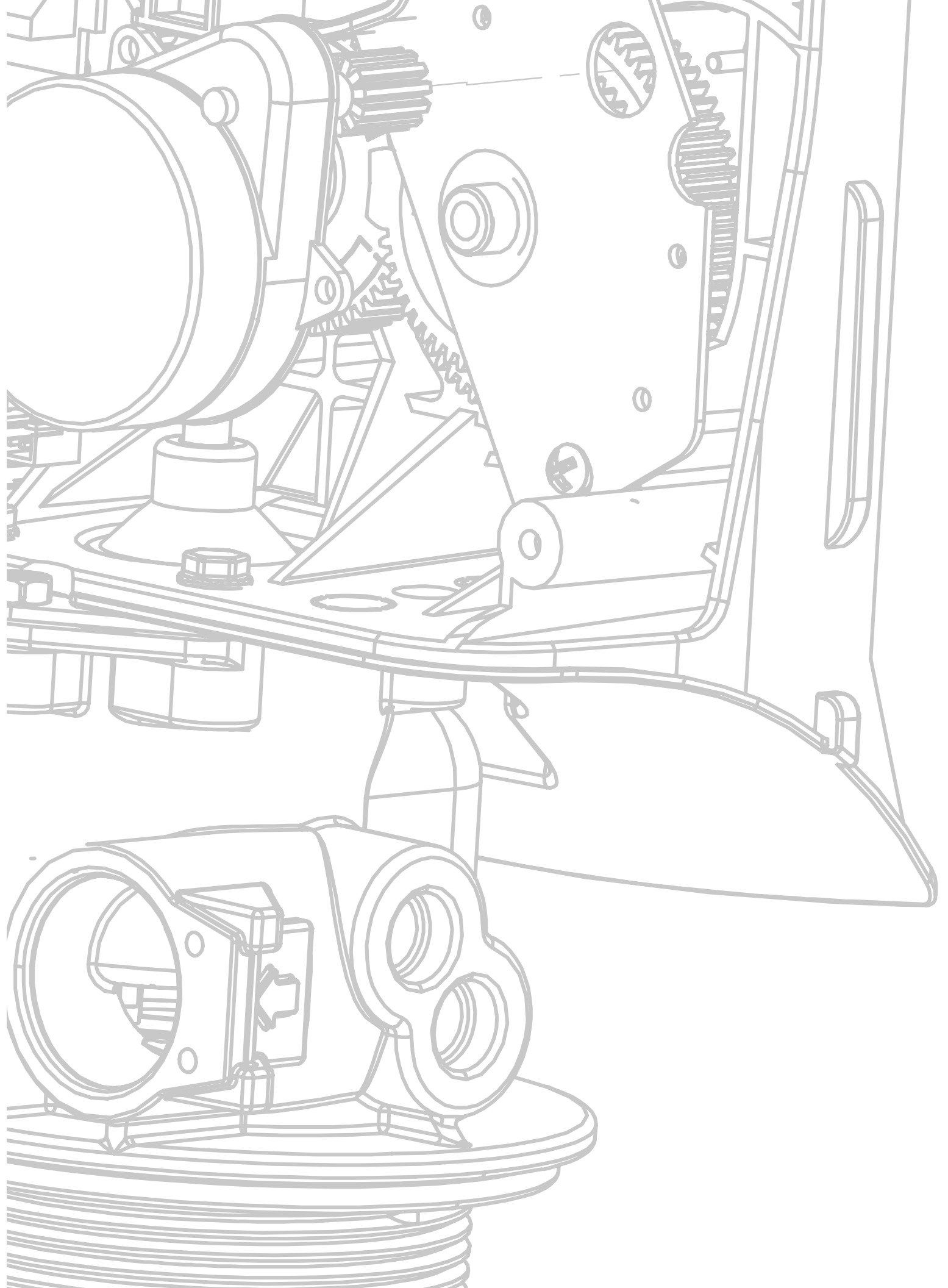

TDC warrants that your new water conditioner is built of quality material and workmanship. When properly installed and maintained, it will give years of trouble free service.

Seven Year Complete Parts Warranty

TDC will replace any part which fails within 84 months from date of manufacture, as indicated by the serial number, provided the failure is due to a defect in material or workmanship. The only exception shall be when proof of purchase or installation is provided and then the warranty period shall be from the date thereof.

Ten Year Warranty on Mineral Tanks and Brine Tanks

TDC will provide a replacement mineral tank or brine tank to any original equipment purchaser in possession of a tank that fails within 120 months, provided that the water conditioner is at all times operated in accordance with specifications and not subject to freezing.

General Provisions

Damage to any part of this water filter as a result of misuse, misapplication, neglect, alteration, accident, installation or operation contrary to our printed instructions, damage to ion exchange resin and seals caused by chlorine / chloramines in the water supply, or damage caused by any force of nature is not covered in this warranty. We will repair or replace defective parts if our warranty department determines it to be defective under the terms of this warranty. TDC™ assumes no responsibility for consequential damage, labor or expense incurred as a result of a defect or failure.

TOLL-FREE: 1-866-874-2532

The Distribution Center

100 Hanlan, Woodbridge, ON L4L 4V8