



TREC Ireland

Addendum: New PTV Obstacles

v2023_1 (release date: 01.04.2023)

This addendum is designed to officially allow the introduction of new PTV obstacles that can be used by groups in addition to the obstacles listed in the current TREC Ireland Rule Book (version released April 2023).

The new obstacles may only be used at local or non-championship events unless the obstacle has been specified as suitable for use in Championship events by TREC Ireland.

The addendum may be updated from time to time in between releases of the official Rule Book and Data Sheet documentation. The obstacle number includes the year that they have been introduced.

Successful obstacles may then be moved to the official list of TREC Ireland PTV Obstacles on a permanent basis at the next review (every two years). The remaining obstacles may either remain on a trial basis for a little longer or be phased out.

Obstacle No	Obstacle Name	Relevant Score Sheet	Standard of competition	Date added
2023-1	Bramble Tangle Ridden	S/Sheet 3	Local, non-championship	Apr-2023
2023-2	Teardrop One-Handed	S/Sheet 1	Local, non-championship	Apr-2023
2023-3	Ridden Weave	S/Sheet 3	Local, non-championship	Apr-2023
2023-4	Bramble Tangle In-Hand	S/Sheet 4	Local, non-championship	Apr-2023
2023-5	In-Hand Weave	S/Sheet 4	Local, non-championship	Apr-2023
2023-6	Road Closed	S/Sheet 3	Local, non-championship	Apr-2023
2023-7	Tree Roots	S/Sheet 3	Local, non-championship	Apr-2023
2023-8	Stepping Stones	S/Sheet 4	Local, non-championship	Apr-2023

The six new generic TREC Ireland score sheets are based on how an obstacle is judged (by gait, style or time) and whether the obstacle is ridden or in-hand. The various categories (which have been colour coded for easy identification) are as follows:

[S/Sheet 1: Ridden, Gait]
[S/Sheet 2: In-Hand, Gait]

[S/Sheet 3: Ridden, Style]
[S/Sheet 4: In-Hand, Style]

[S/Sheet 5: Immobilities, Time]
[S/Sheet 6: Mounting, Style]



TREC Ireland PTV DATA SHEETS

T.I.
2023-1

[S/Sheet 3: Ridden, Style]

Note: compulsory WALK only

Bramble Tangle Ridden

Level	Height top branch	Inner Gap
1	1.5 m	0.8m
2	1.5m	0.7m
3	1.5m	0.5m
4	1.5m	0.5m

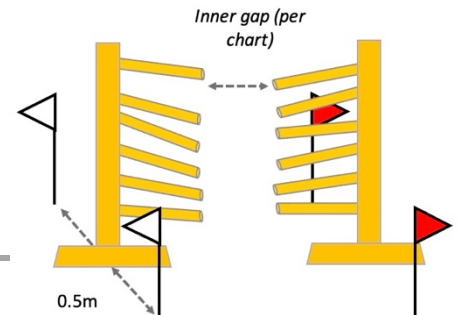

Equipment...

- 2 red flags, 2 white flags, 1 number
- 2 upright posts
- 8 – 12 lengths of soft foam, or soft leafy branches (secured to the uprights)

Features...

- Fronds of soft foam strips or leafy branches on each side of the path through the obstacle
- Distance (inner gap) between foam strips or branches **0.5-0.8m**

Objectives...

- Must be negotiated in walk
- Demonstrates the correct approach of the rider & willingness of the horse

Effectiveness faults...

- Running out or circling before entering the obstacle
- Refusal including stepping back
- Change of gait, including break in forward motion
- Rectified error of course

Style evaluation...

- Regular forward motion
- Good rider position
- Horse and rider maintaining balance at all times
- Horse moving in a straight line
- Discreet rider aids

Penalties...

- Brutality -5 points
- Dangerous riding -5 points
- Fall of the horse or rider -10 points

Obstacle design courtesy of TREC GB, illustrations recreated by Jill Davies



TREC Ireland PTV DATA SHEETS

T.I.
2023-2

[S/Sheet 1: Ridden, Gait]

Note: change of gait is penalised

Teardrop One-Handed

Level 1	Gait: Walk, Trot, Canter
Level 2	
Level 3	Gait: Trot, Canter
Level 4	

Equipment...

- 2 red flags, 2 white flags, 1 number
- Barrel or tall cone (or similar marker)

Features...

- Entrance/exit gate:
 - 3m wide for L1 & L2
 - 2m wide for L3 & L4
- Recommended distances from entrance/exit gate to barrel:
 - 10m for L1 & L2
 - 15m for L3 & L4

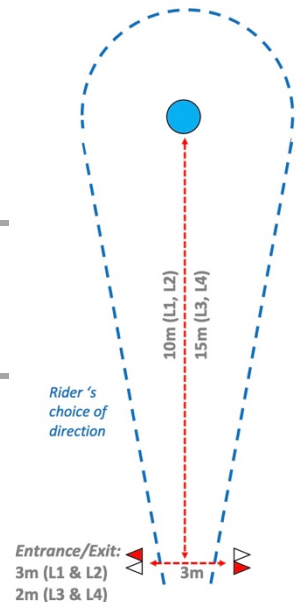

Objectives...

- To show the appropriateness of the rider's aids & obedience of the horse, while negotiating the obstacle **with one hand only on the reins**
- Ride around the barrel and return through exit gate (without knocking over the barrel)
- Rider's choice of rein and gait; free choice of circle size, to suit rider/horse

Effectiveness faults...

- Change of gait, including break in forward motion
- Running out or circling before entering the obstacle
- Refusal including stepping back
- Touching the barrel / cone / marker
- Rectified error of course

Choice of Gait...

- Walk (Level 1 and Level 2 only; Level 3 and Level 4 can't choose Walk)
- Trot
- Canter

Where there is a change of the gait the obstacle is marked at the lowest gait. Resumption of initial gait is not acknowledged.

Penalties...

- Brutality -5 points
- Dangerous riding -5 points
- Fall of the horse or rider -10 points

Obstacle design courtesy of TREC GB, illustrations recreated by Jill Davies



TREC Ireland PTV DATA SHEETS

T.I.
2023-3

[S/Sheet 3: Ridden, Style]

Note: compulsory WALK only

Ridden Weave (Arena only)

	Corridor Width
Level 1	5m minimum, based on the
Level 2	actual objects used
Level 3	4m minimum, based on the
Level 4	actual objects used

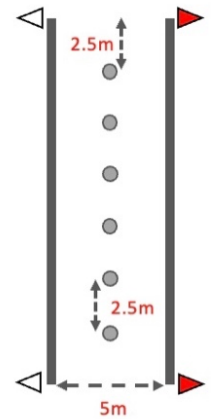

Equipment...

- 2 red flags, 2 white flags, 1 number
- **6 tall** poles, cone or objects
- Marker cones (or flour, etc) to mark edges of corridor route (optional)

Features...

- Poles, cones or similar objects placed a minimum of **2m-2.5m** apart
- Minimum width of route corridor 5m or 4m depending on level
- The dimensions of the obstacle and number of poles may be altered between levels

Objectives...

- Obstacle must be negotiated in a walk.
- Demonstrate the correct approach and aids of the rider
- Demonstrate the flexibility and obedience of the horse by weaving around the objects while remaining inside the corridor route

Effectiveness faults...

- Touching the poles, cones or objects
- Running out or circling before entering the obstacle
- Refusal including stepping back
- Rectified error of course
- Break in forward motion, change of gait

Style evaluation...

- Regular forward motion
- Good rider position, with discreet aids
- Horse and rider maintaining balance at all times

Penalties...

- Brutality -5 points
- Dangerous riding -5 points
- Fall of the horse or rider -10 points
- Foot outside -10 points

Obstacle design courtesy of TREC GB, illustrations recreated by Jill Davies



TREC Ireland PTV DATA SHEETS

T.I.
2023-4

[S/Sheet 4: In-Hand, Style]

Note: compulsory WALK only

Bramble Tangle In-Hand

Level	Height top branch	Inner Gap
1	1.2 m	0.8m
2	1.2m	0.7m
3	1.5m	0.5m
4	1.5m	0.5m

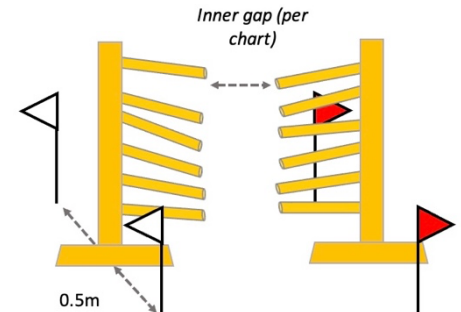

Equipment...

- 2 red flags, 2 white flags, 1 number
- 1 sign "in-hand"
- 2 upright posts (for the vertical arrangement)
- 8 – 12 lengths of soft foam, or soft leafy branches (secured to the uprights)

Features...

- Fronds of soft foam strips or leafy branches on each side of the path through the obstacle
- Distance (inner gap) between foam strips or branches **0.5-0.8m**

Objectives...

- Must be negotiated in walk
- Demonstrates the correct approach of the rider & willingness of the horse

Effectiveness faults...

- Running out or circling before entering the obstacle
- Refusal including stepping back
- Break in forward motion, including change of gait
- Rectified error of course

Style evaluation...

- Regular forward motion
- Rider leading on a loose rein
- The horse's muzzle not ahead of the rider's shoulder line
- Good position of the rider in relation to the horse
- Horse moving in a straight line
- Discreet rider aids

Penalties...

- Flapping stirrup(s), reins not over the head of the horse -1 point
- Brutality -5 points
- Dangerous method, includes fall of rider -5 points
- Fall of the horse -10 points

Obstacle design courtesy of TREC GB, illustrations recreated by Jill Davies



TREC Ireland PTV DATA SHEETS

T.I.
2023-5

[S/Sheet 4: In-Hand, Style] In-Hand Weave (Arena only)

Note: compulsory WALK only

	Corridor Width
Level 1	5m minimum, based on the
Level 2	actual objects used
Level 3	4m minimum, based on the
Level 4	actual objects used

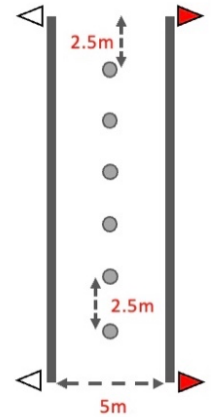

Equipment...

- 2 red flags, 2 white flags, 1 number
- 1 sign "in-hand"
- **6 tall** poles, cone or objects
- Marker cones (or flour, etc) to mark edges of corridor route (optional)

Features...

- Poles, cones or similar objects placed a minimum of **2m-2.5m** apart
- Minimum width of route corridor 5m or 4m depending on level
- The dimensions of the obstacle and number of poles may be altered between levels

Objectives...

- Obstacle must be negotiated in a walk.
- Demonstrate the flexibility and obedience of the horse by weaving around the objects while remaining inside the corridor route

Effectiveness faults...

- Touching the poles, cones or objects in the obstacle route
- Running out or circling before entering the obstacle
- Refusal including stepping back
- Break in forward motion, including change of gait
- Rectified error of course

Style evaluation...

- Regular forward motion
- Rider leading on a loose rein
- The horse's muzzle not ahead of the rider's shoulder line
- Good position of the rider in relation to the horse
- Discreet rider aids

Penalties...

- Flapping stirrup(s), reins not over the head of the horse -1 point
- Brutality -5 points
- Dangerous method, includes fall of rider -5 points
- Fall of the horse -10 points
- Foot outside -10 points

Obstacle design courtesy of TREC GB, illustrations recreated by Jill Davies



TREC Ireland PTV DATA SHEETS

T.I.
2023-6

[S/Sheet 3: Ridden, Style]

Note: compulsory WALK only

Road Closed (3-point turn)

Level 1	The same for all levels
Level 2	The same for all levels
Level 3	The same for all levels
Level 4	The same for all levels

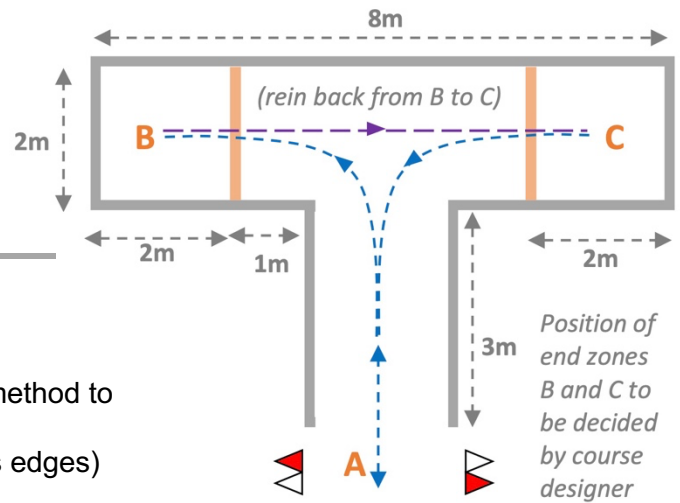

Equipment...

- 2 red flags and 2 white flags, 1 number
- Letters B and C
- Poles (2x4m, 2x2m, 4x3m) or alternative method to mark edges (eg cones, flour, etc)
- Cones or flour to mark zones (not same as edges)

Features...

- Overall dimensions: 8m x 5m
- Corridor width inside obstacle: 2m
- **B and C positions to be decided by the Chef de Piste**

Objectives...

- Obstacle must be negotiated in a walk (A - B - C - A)
- Demonstrate the correct approach of the rider and willingness of the horse
- **Horse's front feet to go over the marked line in zone B, back feet to go over the marked line in zone C**

Effectiveness faults...

- Running out or circling before entering the obstacle
- Refusal including stepping back (except when reining back from B to C)
- Break in forward motion, change of gait (stopping at B & C to perform change of direction is allowed)
- Rectified error of course
- Knocking the poles or stepping on the marked edges (if poles not used)

Style evaluation...

- Regular movement, both forwards and backwards
- Good rider position, with discreet aids
- Horse and rider maintaining balance at all times
- Calmness and obedience of the horse

Penalties...

- Brutality -5 points
- Dangerous riding -5 points
- Fall of the horse or rider -10 points
- Foot outside -10 points

Obstacle design courtesy of TREC GB, illustrations recreated by Jill Davies



TREC Ireland PTV DATA SHEETS

T.I.
2023-7

[S/Sheet 3: Ridden, Style]

Note: compulsory TROT only

Tree Roots

Level	Suggested variations
Level 1	Fan of 4 poles, on ground or raised
Level 2	Obstacle negotiated in TROT only
Level 3	Fan of up to 6 poles, raised
Level 4	Obstacle negotiated in TROT only

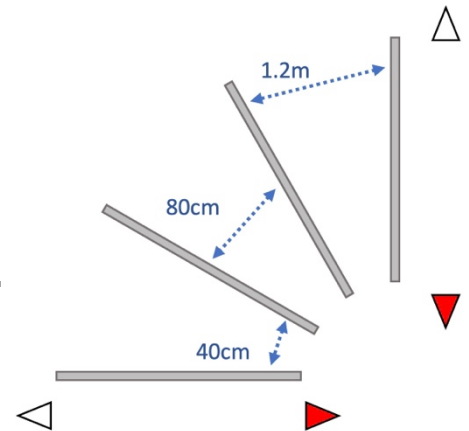

Equipment...

- 2 red flags, 2 white flags, 1 number
- 4 – 6 Poles
- 8 – 12 pole risers (as required)

Features...

- Poles or similar
- If risers are used, 20 cm maximum height of the riser
- Obstacle must be in a fan or arc shape, to suit all sizes of equines
- Suggested distances of poles on arc, outer 1.2m, middle 80cm, inner 40cm minimum

Objectives...

- Obstacle must be negotiated in **TROT**
- Demonstrate the correct approach of the rider and willingness of the horse

Effectiveness faults...

- Running out or circling before entering the obstacle
- Refusal including stepping back
- Rectified error of course
- Change of gait, including break in forward motion
- Dislodging the poles, when raised

Style evaluation...

- Touching the poles
- Regular forward motion
- Good rider position
- Horse and rider maintaining balance at all times
- Discreet rider aids

Penalties...

- Brutality -5 points
- Dangerous riding -5 points
- Fall of the horse or rider -10 points

Obstacle design courtesy of TREC GB, illustrations recreated by Jill Davies



TREC Ireland PTV DATA SHEETS

T.I.
2023-8

[S/Sheet 4: In-Hand, Style]

Stepping Stones

Note: compulsory WALK only

Level 1	5-6 stepping stones
Level 2	max 30cm apart
Level 3	6-8 stepping stones
Level 4	max 30cm apart

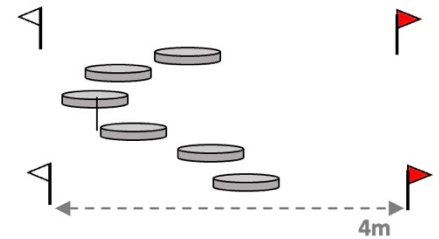

Equipment...

- 2 red flags and 2 white flags, 1 number
- 6-8 "stepping stones" eg non-slip rubber discs, hoops, concrete discs, etc. or the special Mounted Games pots

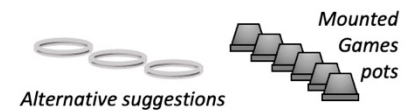

IMPORTANT: If stones greater than 10cm (4") in height are being used, an alternative route with flat stones must also be provided.

Features...

- The stepping stones may be placed in a straight line or with some offset/curved
- Maximum space between the stones 30cm

Objectives...

- Obstacle must be negotiated in a walk
- The rider must negotiate the path of stepping stones while leading their horse beside them
- Both horse and rider to go through entrance and exit flags
- Demonstrates the correct approach of the rider and willingness of the horse

Effectiveness faults...

- Running out or circling before entering the obstacle
- Refusal including stepping back
- Rectified error of course
- Break in forward motion, hesitation
- Rider's foot touches the ground between stones

Style evaluation...

- Regular forward motion
- Rider leading on a loose rein
- The horse's muzzle not ahead of the rider's shoulder line
- Good position of the rider in relation to the horse
- Horse and rider maintain balance at all times
- Discreet rider aids

Penalties...

- Flapping stirrup(s) or reins not over the head of the horse -1 point
- Brutality -5 points
- Dangerous method, includes fall of rider -5 points
- Fall of the horse -10 points

Obstacle illustrations courtesy of Jill Davies