

Cupola Data

Overall Height = 6'-3"
 Base Width = 3'-8"
 Unit Weight = 125 lbs.

Optional Window Panel Styles



304
Keystone

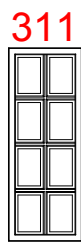

311
Square

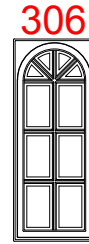

306
Round Top

Note: Windows also available without panes.

Optional Cupola Finials



36" Cross
8"Ø Sphere



36" Aluminum Spire
8"Ø Sphere

Weathervane selection at :
www.whitehallproducts.com

Base Panels - WPK Model Standard with (8) K-glass Windows. Optional Window Panel Styles Listed Above.

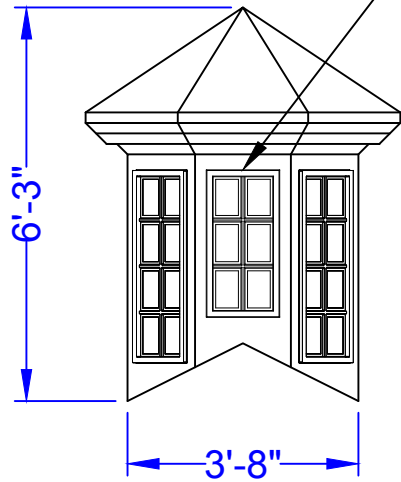

Elevation View

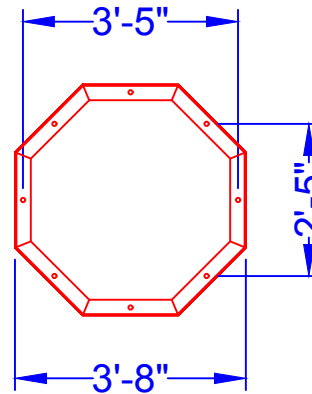

Mounting Detail

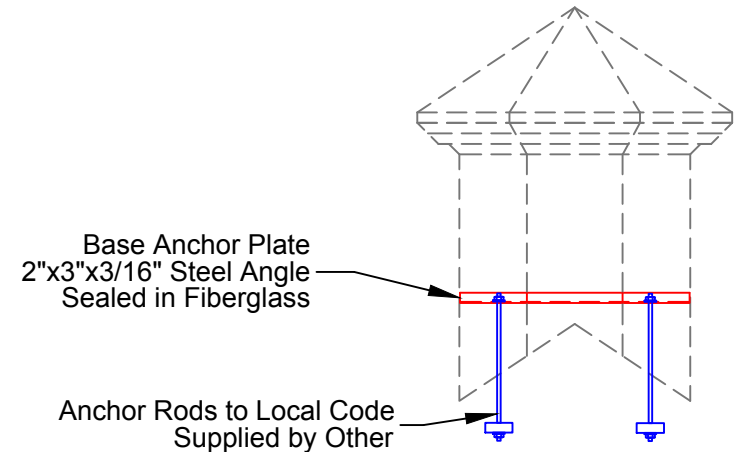

Skeleton View



PIEDMONT
 COMPOSITES & TOOLING

33 Lewittes Rd.
 Taylorsville, NC 28681
 Phone: 828-632-8883
 Fax: 828-632-5585
www.piedmontcomposites.com

CUPOLA

Model :

800WPK

Scale:
 N/A

Drawn by:
 K.SHERRILL

Created On
 N/A

Updated On
 05/09/19

Note: All drawings are the property of Piedmont Composites & Tooling, LLC. Variation in material thickness, dimension and weight may occur. PCT reserves the right to change or modify design at anytime without notice.