

# 520 HN



**Flow Modulated with Hydro-generated Ignition**

**Suitable for heating potable water only - Not approved for space heating purposes  
(Intended for variable flow applications with steady cold water inlet temperatures)**



# BOSCH



## 520-HN-N 520-HN-L

**Warning:** If the information in this manual is not followed exactly, a fire or explosion may result causing property damage, personal injury or death. Do not store or use gasoline or other flammable vapor and liquids in the vicinity of this or any other appliance.

Improper installation, adjustment, alteration, service or maintenance can cause injury or property damage. Refer to this manual. For assistance or additional information consult a qualified installer, service agency or the gas supplier.

In the Commonwealth of Massachusetts this product must be installed by a licensed plumber or gas fitter.

Upon completion of the installation, these instructions should be handed to the user of the appliance for future reference.

### What to do if you smell gas

- Close gas valve. Open windows.
- Do not try to light any appliance.
- Do not touch any electrical switch; do not use any phone in your building.
- Immediately call your gas supplier from a neighbor's phone. Follow the gas supplier's instructions.
- If you cannot reach your gas supplier, call the fire department.
- Installation and service must be performed by a qualified installer, service agency or the gas supplier.



# Index

<b>1</b>	<b>Warning</b>	<b>2</b>
<b>2</b>	<b>Appliance details</b>	<b>3</b>
2.1	520 HN specifications (Technical data)	3
2.2	Unpacking the 520 HN heater	4
2.3	General rules to follow for safe operation	4
2.4	Dimensions and installation clearances	5
<b>3</b>	<b>Installation instructions</b>	<b>6</b>
3.1	Introduction	6
3.2	Proper location for installing your heater	6
3.3	Venting	6
3.4	Combustion air requirements	9
3.5	Mounting Heater	9
3.6	Gas piping & connections	11
3.7	Measuring gas pressure	13
3.8	Water connections	13
3.9	Recirculation application	14
<b>4</b>	<b>Operation instructions</b>	<b>14</b>
4.1	For your safety, read before operating your water heater	14
4.2	Lighting instructions	15
4.3	To turn off appliance	15
4.4	Adjusting the water temperature	15
4.5	Power adjustment knob	16
4.6	Draining the appliance	16
<b>5</b>	<b>Maintenance and service</b>	<b>17</b>
5.1	Maintenance intervals	17
5.2	Water valve	17
5.3	Pilot	17
5.4	Main burners	18
5.5	Vent assembly	18
5.6	Mineral scale build-up	18
<b>6</b>	<b>Troubleshooting</b>	<b>19</b>
6.1	Introduction	19
6.2	No spark at pilot with water flow	19
6.3	Spark appears when hot water is turned on, but pilot and burners will not ignite	19
6.4	Pilot lights, but burners will not come on.	20
6.5	Main burners go out during hot water use	20
6.6	Hot water temperature fluctuates at tap	21
6.7	Water is too hot	21
6.8	Water is not hot enough	22
6.9	Low hot water pressure	22
6.10	Noise when heater is running	22
6.11	Burners do not burn cleanly, yellow flames when operating	22
<b>7</b>	<b>Protecting the environment</b>	<b>23</b>
<b>8</b>	<b>Interior components and diagram parts list</b>	<b>24</b>
8.1	Interior components	24
8.2	Components diagram	25
8.3	Parts list	26
<b>9</b>	<b>Fifteen Year Limited Warranty</b>	<b>27</b>

## 1 Warning



**Warning:** The heater must be isolated from the gas supply piping system during any pressure testing of that system at test pressures equal to or more than 0.5 psig.



**Caution:** Any changes or modifications not expressly approved by the party responsible for compliance could void the user's authority to operate the equipment.

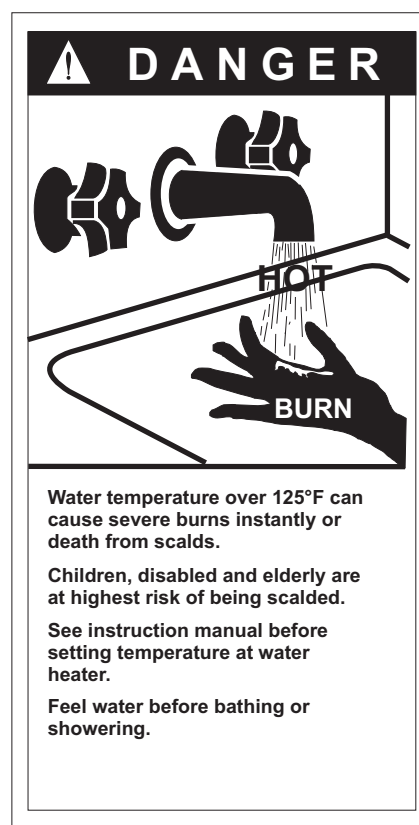

Fig. 1

## 2 Appliance details

### 2.1 520 HN specifications (Technical data)

Approved in US/Canada

#### Capacity

520 HN: 4.36 GPM

#### Minimum input

520 HN: 30,735 Btu/hr

#### Maximum input

520 HN: 117 000 Btu/hr

#### Min. Output

520 HN: 23 906 Btu/hr

#### Maximum output

520 HN: 91 525 Btu/hr

#### Efficiency in %

Efficiency 80%

#### Gas Requirement

Gas connection - 3/4" NPT

Inlet gas pressure under maximum operation:\*

- Propane: 10.5" - 14" water column
- Natural Gas: 5.7" - 14" water column.

\* To measure Gas Pressure, see Measuring Gas Pressure, chapter 3.7.

#### Venting

- Natural Draft
- Vent diameter - 5" or 6"
- Minimum height (feet) - 6' with no elbows
- Vertical termination through roof or into chimney.
- Sidewall termination only with AQ4 power vent kit.

#### Water

- Hot water connection - 1/2" NPT
- Cold water connection - 1/2" NPT
- Water valve material: Fiberglass reinforced polyimide (PA)
- Minimum water flow to activate heater: 0.5 gallon/minute (1.9 l/m)
- Minimum recommended water pressure: 30 PSI (2.07 bar)
- Connections:
  - Bottom of heater

- Temperature rises:<sup>1)</sup>
  - 45F rise @ 4.1 gpm
  - 50F rise @ 3.7 gpm
  - 55F rise @ 3.4 gpm
  - 65F rise @ 2.8 gpm
  - 77F rise @ 2.4 gpm
  - 90F rise @ 2.0 gpm

#### Dimensions

- Depth (in): 8.66" (220 mm)
- Width (in): 16.73" (425 mm)
- Height (in): 25.75" (655 mm)
- Weight: 35 pounds (16 kg).

#### Gas types

Natural Gas

LP Gas

#### Safety devices

- Flame failure device (ionization flame rod)
- Pressure relief valve (Available as accessory)
- Overheat prevention (temperature limiter).

#### Water protection

IP X4.

#### Accessories (Bosch part #)

- Freeze prevention kit (7709003775)<sup>2)</sup>
- Pressure relief valve (FWL-2).

1) Depending on gas pressure and altitude.

2) The freeze prevention kit is designed to provide protection for the water heater down to approximately 5°F for short term conditions only. It will not protect the appliance in areas where the temperature is routinely expected to be below freezing.  
- The freeze prevention kit will not protect plumbing outside the appliance from freezing. Precautions should be taken.

## 2.2 Unpacking the 520 HN heater

Before installing the unit, be certain you have the correct heater for your type of Gas - Propane or Natural Gas. Identification labels are found on the shipping box, and on the rating plate which is located on the right side panel of the cover.

- ▶ **Installer must fill out checklist on back cover to provide details in case service or warranty coverage is required.**

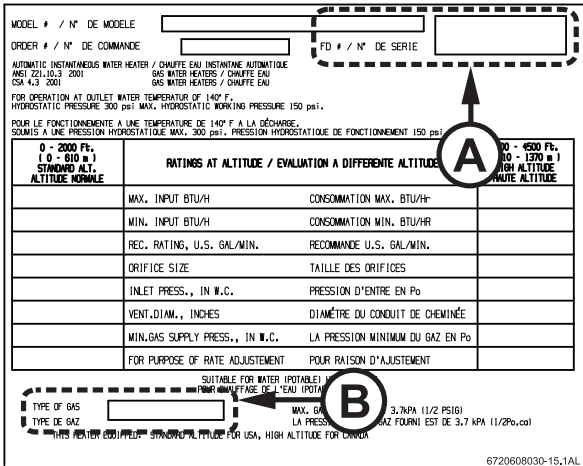

Fig. 2 Rating plate

- A** Serial number
- B** Type of gas

The box includes:

- Hot and cold water connection fittings
- Mounting screws
- Product registration card
- Installation manual
- Incandescent particle tray.

**Do not lose this manual, there is a charge for a replacement.**

Please complete and return the enclosed product registration card.

**The 520 HN is not approved or designed for:**

- Manufactured (mobile) homes, RV's or boats
- Heating or other recirculating/pumping applications\*
- Solar/preheat backup or high temperature booster use
- Installation in bathroom, bedroom or other occupied rooms normally kept closed.

\* This includes domestic hot water circulator pump loop systems that may be installed in home hot water system prior to installing this unit. An approved recirculation design can be found in chapter 3.9.

## 2.3 General rules to follow for safe operation

1. You must follow these instructions when you install your heater. In the United States: The installation must conform with local codes or, in the absence of local codes, the National Fuel Gas Code ANSI Z223.1/ NFPA 54.

In Canada: The Installation must conform with CGA B149.(1,2) INSTALLATION CODES and /or local installation codes.

2. Carefully plan where to install the heater. Proper clearances must be followed.

3. The appliance must be isolated from the gas supply piping system by closing its individual manual gas shutoff valve (not supplied with heater) during any pressure testing in excess of 1/2 Psig (3.5 kPa).

The appliance and its gas connection must be leak tested before placing the appliance in operation.

4. Keep water heater area clear and free from combustibles and flammable liquids. Do not locate the heater over any material which might burn.

5. **Correct gas pressure** is critical for the optimum operation of this heater. Gas piping must be sized to provide the required pressure at the maximum output of the heater, while all the other gas appliances are in operation. Check with your local gas supplier, and see chapter 3.6 and 3.7 to verify proper gas line sizing.

6. Should overheating occur or the gas supply fail to shut off, turn off the gas supply at the manual gas shut off valve, on the gas line. Note: manual gas shutoff valve is not supplied with the heater.

7. Do not use this appliance if any part has been underwater. Immediately call a qualified service technician to inspect the appliance and to replace any part of the control system and any gas control which has been underwater.



BOSCH is constantly improving its products, therefore specifications are subject to change without prior notice.

## 2.4 Dimensions and installation clearances

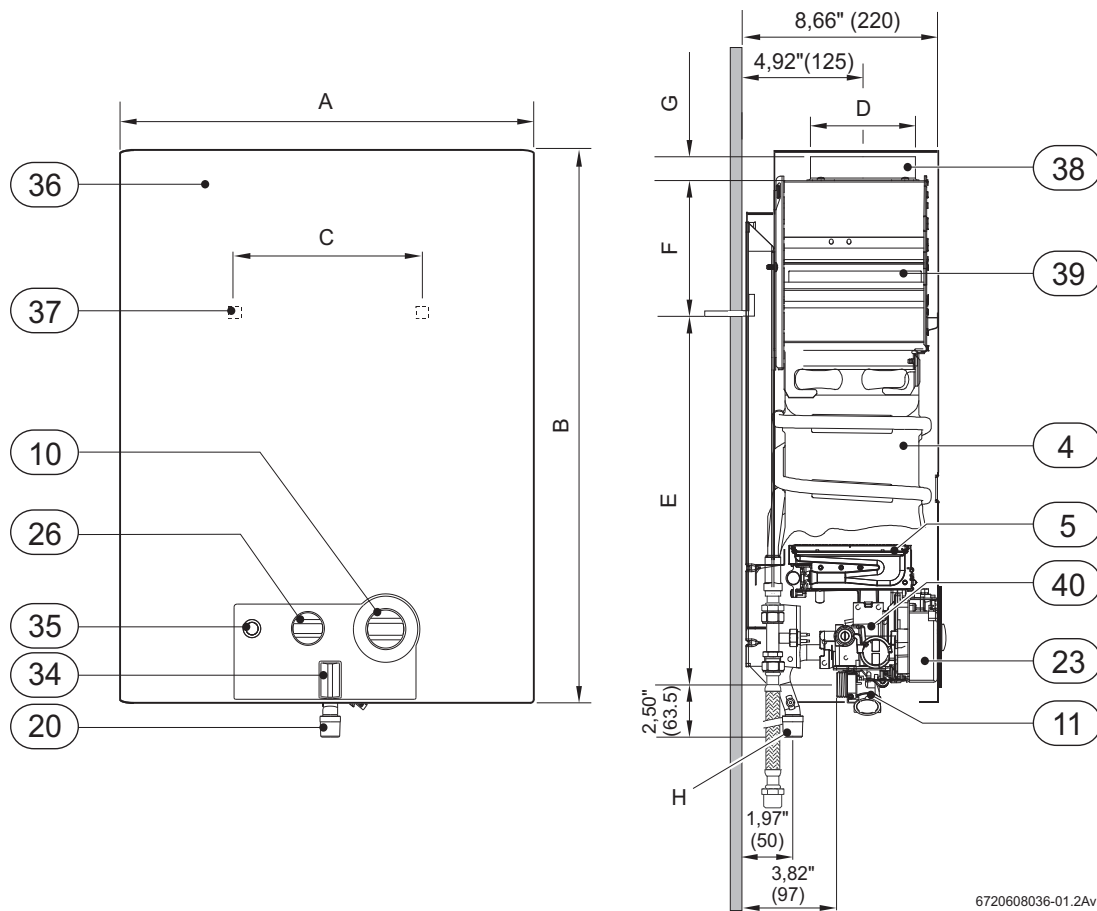

Fig. 3 Dimensions in Inches and (mm)

- 4 Heat exchanger
- 5 Burner
- 10 Flow control knob
- 11 Water valve
- 20 Gas connection
- 23 Ignition unit
- 26 Power adjustment knob
- 34 LED indicator for burner status
- 35 On/Off switch
- 36 Front cover
- 37 Mounting holes
- 38 Exhaust pipe union
- 39 Draft diverter with flue gas sensor
- 40 Gas valve

	Dimensions inches (mm)
	<b>520 HN</b>
<b>A</b>	16.73" (425)
<b>B</b>	25.75" (655)
<b>C</b>	13.15" (334)
<b>D</b>	5.11" (130)
<b>E</b>	21.25" (540)
<b>F</b>	2.55" (65)
<b>G</b>	1.18" (30)
<b>H</b>	3/4"

Table 1 Dimensions in inches (mm)

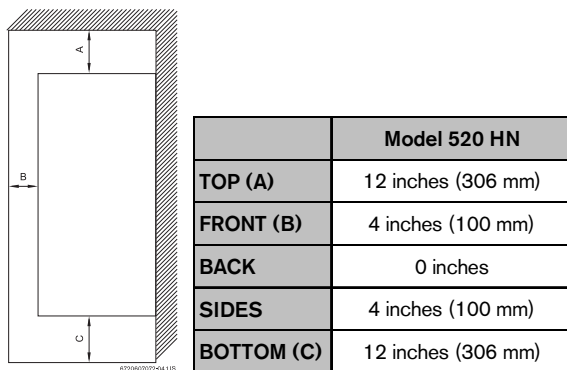

Fig. 4 Minimum clearances

### 3 Installation instructions

#### 3.1 Introduction

Please follow these instructions. Failure to follow instructions may result in:

- ▶ Damage or injury.
- ▶ Improper operation.
- ▶ Loss of warranty.

If you are unable to perform the tasks required to install this heater properly, please contact a locally licensed plumber or gas technician.

Please contact Bosch Water Heating with any questions.

#### 3.2 Proper location for installing your heater

Carefully select the location of the water heater. For your safety and for proper heater operation, you must provide combustion air to the heater and a proper exhaust vent system.

Follow the guidelines below:

- ▶ **1.** Common installation practice is to determine the venting system layout and penetration first, then work back to the heater.
- ▶ **2.** Locate the heater where venting, gas and plumbing connections are feasible and convenient.
- ▶ **3.** The hot water lines should be kept short to save energy. Centrally locating the water heater is best. It is always best to have hot water lines insulated.



**Warning:** The water in this water heater is cold and always remains cold except for the times that hot water is being used. **DO NOT INSTALL IN AN AREA WHERE IT COULD FREEZE.**

Drain the heater entirely if freezing temperatures are anticipated in area where heater is installed. See chapter 4.6 for draining instructions.

To prevent any freeze damage, introduce short bursts of compressed air (20-40psi) through these connections to remove the residual water in the horizontal pipes and water valve.



**Warning:** Flammable materials, gasoline, pressurized containers, or any other items or articles that are potential fire hazards must NOT be placed on or adjacent to the heater. The appliance area must be kept free of all combustible materials, gasoline and other flammable vapors and liquids.



**Warning:** Place the heater in a location where water leaks will do NO DAMAGE to adjacent areas.

#### 3.3 Venting



**Danger:** Do not reduce the vent pipe size. Do not put an elbow directly on top of heater. Failure to follow venting requirements may result in dangerous exhaust gases entering living space.

- ▶ Minimum vent pipe diameter: 5 inches
- ▶ Minimum vertical vent height: 6 feet, with no elbows
- ▶ Establish 12 inch rise before any elbow

The heater must be vented to the outside following all local ordinances and specifications for installing a gas appliance vent or chimney. The heater must be located as close as practicable to a vertically rising chimney or vent that has a listed vent cap at its termination point. The venting system must be designed and constructed so as to develop a positive flow adequate to remove flue gasses to the outdoors. Consult the National Fuel Gas Code if the vent will have elbows or share venting with another natural draft appliance.



**Warning:** Do not combination vent with a power vented appliance.

##### 3.3.1 Horizontal venting



**Warning:** Horizontally venting to a vertically constructed vent stack along an outside wall of a building is not permissible.



**Warning:** Horizontally venting to a sidewall vent terminator (without power vent) is not permissible.

An AQ4 power vent, with a proof-of-draft safety interlock device, is required and is available for sidewall venting. Contact your dealer. In the Commonwealth of Massachusetts power vented applications must utilize proof-of-draft safety interlock device and comply with regulations established for all side wall horizontally vented gas fueled equipment.

##### 3.3.2 Vertical venting

- ▶ A 5 inch diameter gas vent constructed of double wall Type B gas vent is recommended. A 6 inch vent is required in elevations greater than 2000 feet, see Fig. 10. Under no circumstances must the vent pipe be reduced in size.

- ▶ An approved gas vent connector must be attached to the top of the water heater and rise vertically at least 12" before entering into an approved gas vent connector elbow.
- ▶ The minimum vertical gas vent height allowed is 6 feet; horizontal vent connectors and elbows are not to be considered in the total gas vent height.
- ▶ All gas vent sections must be secured to each other with sheet metal screws and be properly supported.

**Horizontal runs:**

Any gas vent section that is greater than 45 degrees from the vertical is considered horizontal. Horizontal sections must slope upwards at least 1/4 inch for every foot of its horizontal length and be properly supported. Keep the horizontal section short and avoid too many elbows. The maximum horizontal run allowed is half of the total vertical vent height; horizontal vent connectors and elbows are not to be considered in the total gas vent height.

**Vent termination:**

The gas vent constructed of double wall Type B gas vent must terminate above the roof surface with a listed vent cap at a height that's in accordance with Fig. 7 and table 2, provided they are at least 8 feet (2.4 m) from a vertical wall or similar obstruction. All other gas vents that are not able to terminate within the minimum specified height allowed must terminate not less than 2 feet (0.6 m) above the highest point where it passes through the roof and at least 2 feet (0.6 m) higher than any vertical wall or similar obstruction within 10 feet (3.1 m).

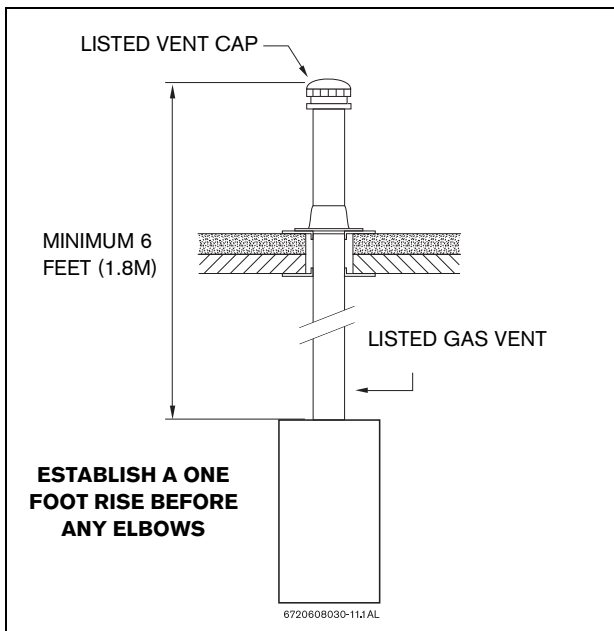

Fig. 5 Flat roof

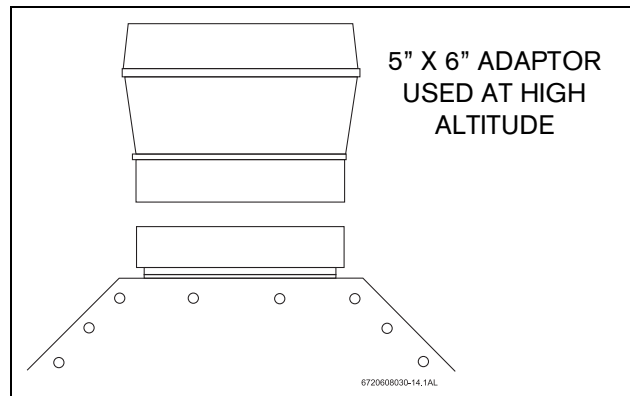

Fig. 6 Vent Adaptor for High Altitude Installations

**Freeze prevention**

In cold climates, components of a tankless water heater can freeze and burst from negative draft. A leading cause of negative draft is combustion appliances in the building not being supplied with sufficient combustion air. A wood stove or furnace can pull its combustion air from the water heater's vent pipe, allowing the cold incoming air to freeze the cold water in the heat exchanger. Supplying more combustion air for all combustion appliances is the solution. A HVAC specialist should be consulted to design solutions for providing more combustion air.

**In cold climates where backdraft is a problem, the freeze prevention kit accessory (7709003775) should be installed.**

**Masonry chimney**

Masonry chimneys shall be built and installed in accordance with NFPS 211 or local codes. A minimum 5" diameter gas vent pipe (metal double wall Type B), or an approved clay flue liner or a listed chimney lining system must be used when venting into a naturally drafting, internal masonry chimney. 6 inch is required in elevations greater than 2000 feet, see Fig. 6. Local codes may require the use of both gas vent and an approved lining system when venting into a masonry chimney. The Commonwealth of Massachusetts requires the use of a listed liner. Lining systems include approved clay flue lining, a listed chimney lining system or other approved material that will resist corrosion, erosion, softening, or cracking from exhaust flue gases at temperatures up to 1800 degrees F. The lining system must be listed for use with naturally drafting, draft hood equipped gas appliances. Follow local codes and refer to NFGC 54 and NFPA 58.

**Existing interior masonry chimney**

The metal gas vent pipe should be permanently mounted inside the masonry chimney. Double wall Type B gas vent is recommended. The masonry chimney may have to be tile or metal lined before the insertion of the gas vent pipe; check local codes for clarification. The lining material must be listed for use only with naturally drafting, draft hood equipped gas appliances. Follow manufacturer's instructions for installation of listed lining material. You may not vent any other fuel burning appliances into any free space remaining in the chimney. The minimum vertical gas vent length within the masonry chimney must be no less than 5 ft (1.5 m); the vent terminator must extend at least 3 feet (0.9 m) above where the chimney meets the roofline and at least 2 feet (0.6 m) higher than any vertical wall or similar obstruction within 10 feet (3.1 m). The top of the gas vent must have an approved vent terminator. See Fig. 8.

GAS VENT TERMINATIONS FOR LISTED VENT CAPS		
Roof pitch	H (minimum) feet	meters
Flat to 6/12	1.0	0.30
6/12 to 7/12	1.25	0.38
Over 7/12 to 8/12	1.5	0.46
Over 8/12 to 9/12	2.0	0.61
Over 9/12 to 10/12	2.5	0.76
Over 10/12 to 11/12	3.25	0.99
Over 11/12 to 12/12	4.0	1.22
Over 12/12 to 14/12	5.0	1.52
Over 14/12 to 16/12	6.0	1.83
Over 16/12 to 18/12	7.0	2.13
Over 18/12 to 20/12	7.5	2.27
Over 20/12 to 21/12	8.0	2.44

Table 2

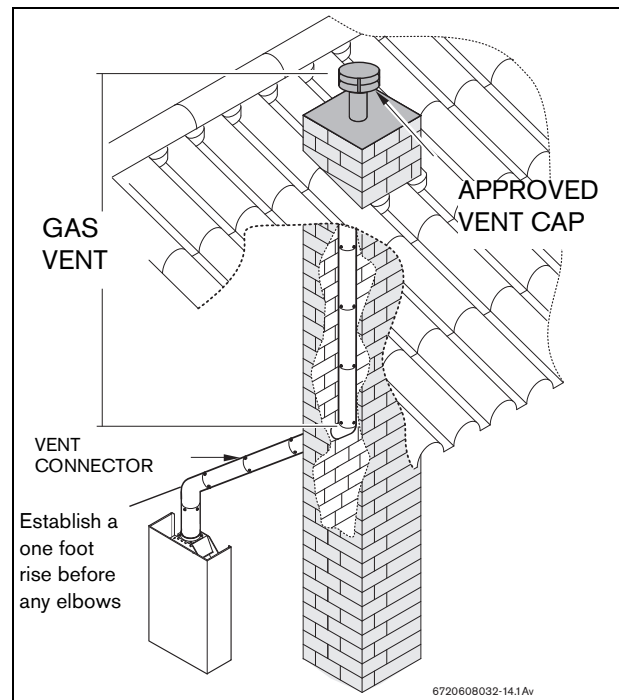

Fig. 8 Masonry chimney

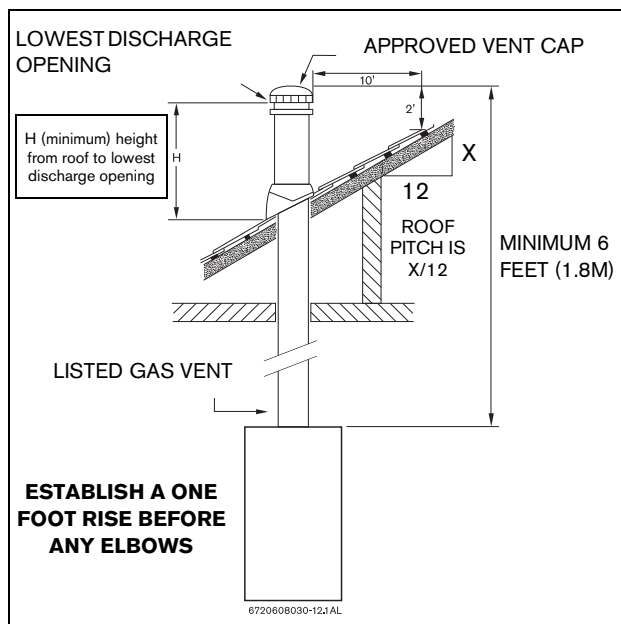

Fig. 7 Pitch roof



### 3.4 Combustion air requirements

The Protankless water heater holds cold water in its copper heat exchanger and water valve when not in use. Because of this, any cold air that comes down through the unit's vent pipe is capable of freezing these components. This Installation Manual specifies the minimum vertical vent pipe and the amount of combustion air required for this unit. When all requirements are followed, the unit will operate properly and safely. However, there may still be a risk of freezing due to negative draft if all the combustion appliances in the structure are not being supplied with sufficient combustion air. A wood stove or furnace can pull its combustion air from the Protankless vent pipe. This allows the cold infiltrating air to potentially freeze the cold water in the AquaStar heater. Damage from freezing is not covered under the manufacturer's warranty. Supplying more combustion air for all combustion appliances is the solution. Follow the instructions on venting and checking adequacy of combustion air. A HVAC specialist should be consulted to design solutions for providing more make-up air if necessary. Observe the following instructions concerning combustion air.

#### Appliances located in unconfined spaces:

- a) An unconfined space is one whose volume is greater than 50 cubic feet per 1000 Btu per hour of the combined rating of all appliances installed in the space. That would be 5850 cubic feet for the Protankless 520 HN alone.
- b) Installations in structures that have been tightly constructed (air infiltration rate of 0.40 ACH or less) must be provided with combustion air per the National Fuel Gas Code. Consult a HVAC specialist if your air infiltration rate is questionable.

#### Appliances located in confined spaces:

The confined space must be provided with two permanent openings, one commencing within 12 inches of the top and one commencing within 12 inches of the bottom of the enclosure. Each opening must have a minimum free area of one square inch per:

- 1000 Btu/hr if all air is taken from inside the building.
- 2000 Btu/hr if all air is taken from the outside by horizontal ducts.
- 4000 Btu/hr if all air is taken from the outside by direct openings or vertical ducts.

Or the confined space must be provided with one permanent opening or duct that is within 12 inches of the ceiling of the enclosure. This opening must have a minimum free area of one square inch per:

- 3000 Btu/hr if all air is taken from the outside by a direct opening or vertical duct.

Louvers, grills and screens have a blocking effect. If the effective free area is not known, increase the sizes of

your openings by 400% if your louvers are wood and by 135% if your louvers are metal. Refer to the National Fuel Gas Code for complete information. In buildings of tight construction all air should be taken from outside.

### 3.5 Mounting Heater

The 520 HN is approved for installation on a combustible wall provided the floor covering below the heater is noncombustible. For installations in an alcove or closet, maintain the minimum clearances to combustible and non-combustible materials listed in Fig. 4.



#### Warning: before starting installation:

- ▶ check that there are no loose parts inside the appliance
- ▶ ensure that gas pipe, gas valve, and burner have no damage and are properly fitted.
- ▶ Read chapter 2.2 to verify proper gas type and to verify all parts are included in box.



Front cover must be removed in order to inspect components visually (see instructions below).

#### Remove cover and inspect.

- ▶ Remove the flow control and power adjustment knobs.
- ▶ Unscrew the cover fixing screws, see Fig. 10.
- ▶ Loosen the two Phillips head screws located on bottom rear of cover. Remove cover by pulling it outward and then lifting upwards.
- ▶ Ensure that the flue terminal is clear.
- ▶ After inspection, replace front cover and tighten screws.

#### Install incandescent particle tray.

- ▶ Install incandescent particle tray using screws provided as shown in Fig. 9.

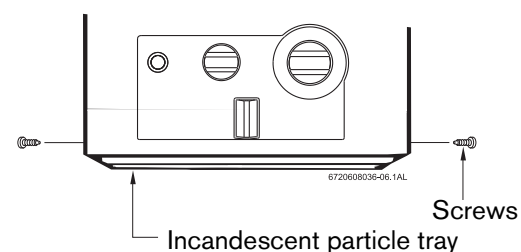



Fig. 9 Incandescent particle tray illustration

**Mounting heater.**

**Warning:**



▶ Do not install this appliance on a carpeted wall.

The heater must be mounted on a wall using appropriate anchoring materials. If wall is a stud wall sheathed with plasterboard, it is recommended that support board(s), either 1x4's or 1/2" (minimum) plywood first be attached across a pair of studs and then the heater should be attached to the support boards. See Fig. 11.

- ▶ Install the two included L shaped hooks to wall studs or support board 13 1/4" apart (See Fig. 11).
- ▶ Hang heater on two L shaped hooks (See Fig. 12).

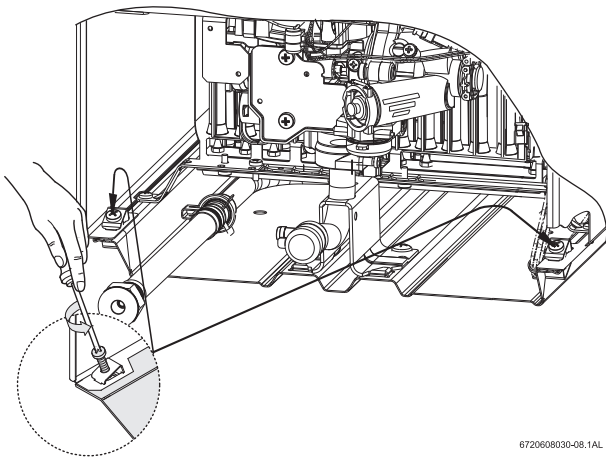

6720608030-08.1AL

Fig. 10 Remove front cover

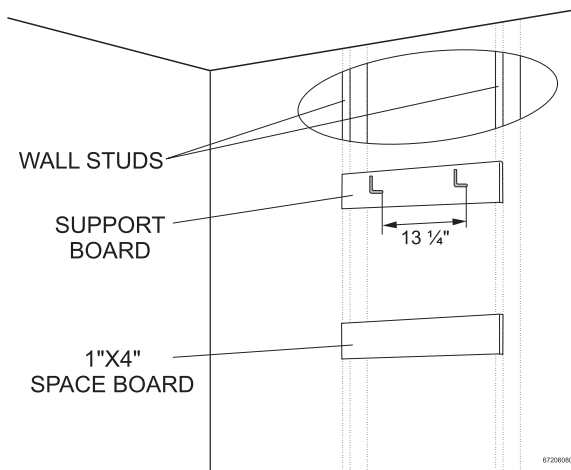

6720608030.10.1AL

Fig. 11 Support board

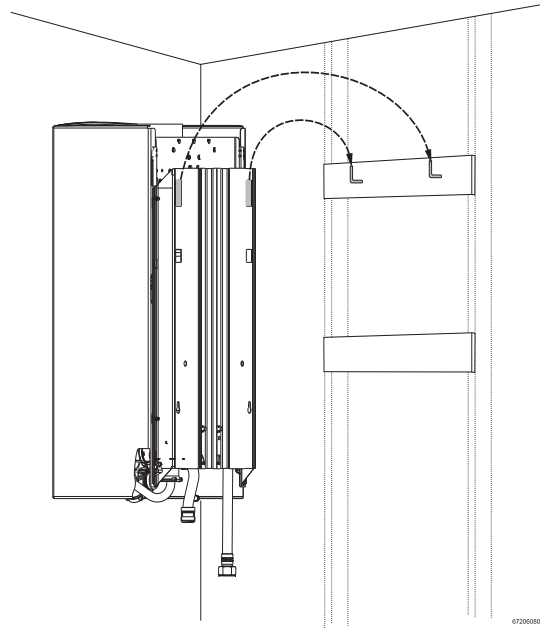

6720608030.05.1AL

Fig. 12 Secure heater to wall

### 3.6 Gas piping & connections



Before connecting the gas supply, check the rating plate on the right side of the heater to be sure that the heater is rated for the same gas to which it will be connected.

In the United States: The installation must conform with local codes or, in the absence of local codes, the National Fuel Gas Code ANSI Z223.1/NFPA 54.

In Canada: The Installation must conform to CGA B149 INSTALLATION CODES and/or local installation codes.

Mount regulator to gas inlet pipe as shown in Fig. 13. The arrow on the back of the regulator indicates the direction of gas flow and must point upwards toward the appliance.

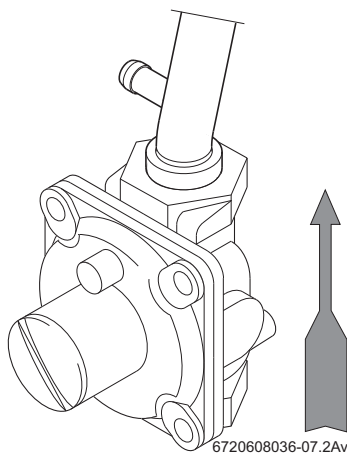

Fig. 13 Installation of Gas Pressure Regulator

**Note:** The 520 HN comes with a gas pressure regulator. Failure to install or altering the gas pressure regulator will be a violation of CSA certification of the unit. The regulator supplied with the heater is preset for the gas shown on the rating plate to the correct pressure. It is an appliance level regulator designed for (low inlet) pressure (less than 1/2 Psig or 14" W.C.).

**Warning:** DO NOT connect to an unregulated or high pressure propane line or to a high pressure commercial natural gas line.

**Warning:** The heater must be isolated from the gas supply piping system during any pressure testing of that system at test pressures equal to or more than 0.5 psig. If overpressure has occurred, such as through improper testing of the gas lines or malfunction of the supply system, the gas valve must be checked for safe operation.

#### GAS CONNECTIONS

- ▶ Install a manual gas shut off valve on the gas supply line.

- ▶ Install a union when connecting gas supply.
- ▶ Attach the appliance regulator to the inlet gas pipe.
- ▶ The minimum diameter required for any appliance connector used is 3/4" NPT.
- ▶ National Fuel Gas Code requires that a sediment trap (drip leg) be installed on gas appliances not so equipped. The drip leg must be accessible and not subject to freezing conditions. Install in accordance with the recommendations of the serving gas supplier.

When connections are made, check for gas leaks at all joints. Apply some gas leak detection solution to all gas fittings. Bubbles are a sign of a leak. A combustible gas detector may also be used to detect for leaks.



**Danger:** If you have a leak, shut off the gas. Tighten appropriate fittings to stop leak. Turn the gas on and check again with a gas leak detection solution. Never test for gas leaks using a match or flame.

#### HIGH ALTITUDE INSTALLATION

The pressure regulator provided with the heater has been adjusted to deliver the proper gas pressure (as indicated on the rating plate and in the manual) for altitude up to 2000 feet (660 meters) above sea level. On appliances being installed above 2000 ft (660 meters) elevation, the inlet gas pressure should be adjusted at installation to the value shown below.

**Note:** The gas pressures specified below refer to pressures taken at the pressure tap on the gas inlet pipe just above the regulator. See chapter 3.7 for measuring gas pressure.

#### MAXIMUM INLET GAS FLOW PRESSURE SETTING

Altitude	Nat. Gas inches W.C.	Liquid Propane inches W.C.
2 000 ft - 4 500 ft	4.6"	8.4"

Table 3 Above 4.500 ft consult your local gas provider

#### GAS LINE SIZING

The gas supply piping should be sized according to the applicable code for a maximum draw of 117,000 BTUH. Measure the length of gas supply line and use the tables in Fig. 14 or the gas line manufacturer's sizing tables to determine the pipe diameter necessary to accommodate the BTU demand of the unit. If there are more gas appliances drawing on the same line, size the gas line according to the total maximum amount of BTU draw for all appliances.

**Note:** Undersizing the gas line may result in diminished output. See chapter 3.7 for the procedure to measure gas pressure.

**Installation instructions**

**FOR NATURAL GAS**

Maximum Capacity of pipe in Cubic Feet of Gas per Hour for Gas Pressure of 0.5 Psig or less and a Pressure drop of 0.3 in Water Column (0.75mbar). (Based on a 0.60 Specific Gravity Gas) Btu numbers given in thousands. Copper tubing is prohibited for use with Natural Gas in the Commonwealth of Massachusetts and not recommended elsewhere.

Follow boxed numbers for piping just one 520 HN (example: 3/4" B.I. Natural Gas pipe for 20 ft (6.1m). will handle 190,000 btu's (55.7 kWh). For multiple appliances combine the total btu input load and then refer to applicable chart below.

Nominal Iron Pipe Size inches	Internal Diameter inches	Length of Black Iron Pipe, Feet													
		10	20	30	40	50	60	70	80	90	100	125	150	175	200
3/4	0.824	278	190	152	130	115	105	96	90	84	79	72	64	59	55
1	1.049	520	350	285	245	215	195	180	170	160	150	130	120	110	100
1 1/4	1.380	1050	730	590	500	440	400	370	350	320	305	275	250	225	210

Length of Flexible Corrugated Stainless Steel Tubing (CSST), Feet							
Tube size, inches	EHD*	10	20	30	40	50	60
1/2	18 EHD	82	58	47	41	37	34
3/4	23 EHD	161	116	96	83	75	68
1	30 EHD	330	231	188	162	144	131
1 1/4	37 EHD	639	456	374	325	292	267

\* EHD = Equivalent Hydraulic Diameter. The greater the value of EHD, the greater the gas capacity of the tubing.

**FOR LP GAS**

Maximum Capacity of Pipe in Thousands of BTU per Hour of Undiluted Petroleum Gases (at 11 inches Water Column Inlet Pressure) (Based on a Pressure Drop of 0.5 Inch Water Column).

\* EHD = Equivalent Hydraulic Diameter. The greater the value of EHD, the greater the gas capacity of the tubing.

Nominal Iron pipe size inches	Black Iron Pipe Length of pipe, Feet										
	10	20	30	40	50	60	80	100	125	150	200
1/2	291	200	160	137	122	110	94	84	74	67	58
3/4	608	418	336	287	255	231	197	175	155	140	120
1	1145	787	632	541	480	434	372	330	292	265	227

Length of Flexible Corrugated Stainless Steel Tubing (CSST), Feet							
Tube size inches	EHD*	10	20	30	40	50	60
1/2	18 EHD	129	91	74	64	58	53
3/4	23 EHD	254	183	151	131	118	107
1	30 EHD	521	365	297	256	227	207
1 1/4	37 EHD	971	661	528	449	397	359

Maximum Capacity of Semi-Rigid copper Tubing in Thousands of BTU per Hour of Undiluted Liquefied Petroleum Gases (at 11 inches Water Column Inlet Pressure).

(Based on a Pressure Drop of 0.5 Inch Water Column)

\* Source National Fuel Gas Code NFPA 54, ANSI Z223.1 - No Additional Allowance is necessary for an ordinary number of fittings

Out side diameter Inch	Copper Length of Tubing, Feet									
	10	20	30	40	50	60	70	80	90	100
3/8	39	26	21	19	-	-	-	-	-	-
1/2	92	62	50	41	37	35	31	29	27	26
5/8	199	131	107	90	79	72	67	62	59	55
3/4	329	216	181	145	131	121	112	104	95	90

Fig. 14

### 3.7 Measuring gas pressure

#### Connecting manometer

- ▶ Shut off gas.
- ▶ Remove front cover and locate inlet gas pressure measuring point on the left side, see Fig. 15.
- ▶ Loosen screw from test point on the left side and connect manometer tube on test point.

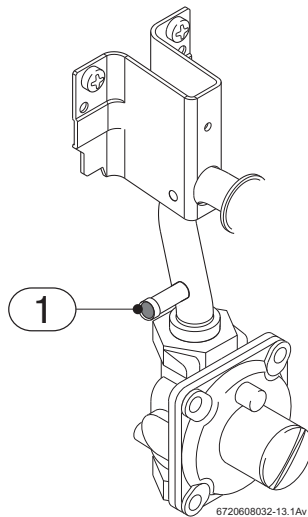

Fig. 15 Gas pressure measuring point

1 Inlet tap

#### Static pressure test

- ▶ Turn gas supply back on.
- ▶ Record static gas pressure reading on back page of manual.

#### Operating pressure test

- ▶ Turn on all hot water taps served by the water heater.
- ▶ Turn flow control (right knob) fully clockwise.
- ▶ Turn power adjustment (left knob) fully counter-clockwise.
- ▶ Turn power adjustment knob fully clockwise.
- ▶ Operate all other gas appliances on same gas piping system at maximum output.
- ▶ Record operating gas pressure reading on back page of manual.

Gas pressures lower than 5.7" W.C. for Natural Gas or 10.5" W.C. for LP Gas will result in insufficient degree rise to the hot water being used and must be corrected. See Gas Line Sizing under chapter 3.6.

### 3.8 Water connections



When facing the heater, the 1/2" cold water inlet is on the bottom right and the hot water outlet is on the bottom left.

- ▶ **Install unions and shutoff or isolation valves when connecting plumbing to the water heater. This will facilitate any necessary cleaning and servicing.**

Although water piping throughout the structure may be other than copper, we require that copper piping or suitably rated stainless steel flex line piping be used for at least three feet before and after the heater (follow local codes if more stringent). Never sweat any rigid piping directly to or beneath the water connections or damage can occur to the internal water valve from heating of the pipe. Plastics or other PEX type plumbing line materials are not allowed for connecting directly to the water heater. Keep water inlet and outlet pipes to no less than 1/2" (12.7mm) diameter to allow the full flow capacity.

It is recommended that all hot water piping be properly insulated to avoid heat loss.

If the cold and hot connections to the heater are reversed, the heater will not function. Be certain there are no loose particles or dirt in the piping. Blow out or flush the lines before connecting to the water heater. Full port valves must be installed on both the cold water supply and hot water outlet lines to facilitate servicing the heater (see Fig. 16). For installation on a private well system with the use of a pressure tank, the lowest pressure range setting recommended is 30-50 psi (2.07 and 3.45bar).

#### Connecting the pressure relief valve (PRV)

A listed pressure relief valve must be installed at the time of installation. **No valve is to be placed between the PRV and the heater.** No reducing coupling or other restriction may be installed in the discharge line. The discharge line must be a minimum of 4" above a drain and installed such that it allows complete drainage of both the PRV and the line.

The location of the PRV must be readily accessible for servicing or replacement, and be mounted as close to the water heater as possible. See Fig. 16. To install the PRV, a suitable fitting connected to an extension on a "T" fitting can be sweated to the hot water line. Support all piping.

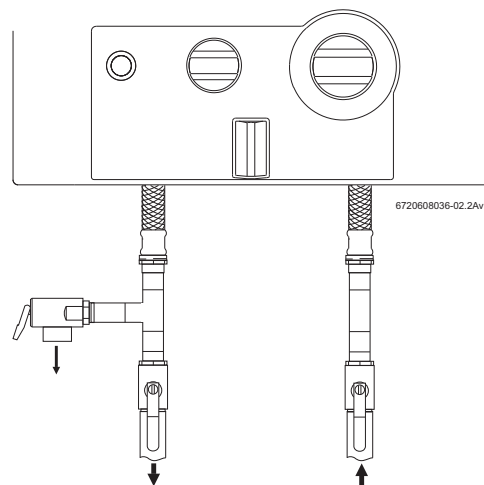

Fig. 16 Plumbing Connections and Pressure Relief Valve

### 3.9 Recirculation application

Since recirculation through the heater is not allowed, the following drawing is provided to outline a recirculation application using the Protankless water heater with an Ariston mini tank water heater. This schematic is for illustration only and must not be used for actual installation without appropriate engineering and technical advice from a professional properly licensed in locality where the installation is made.

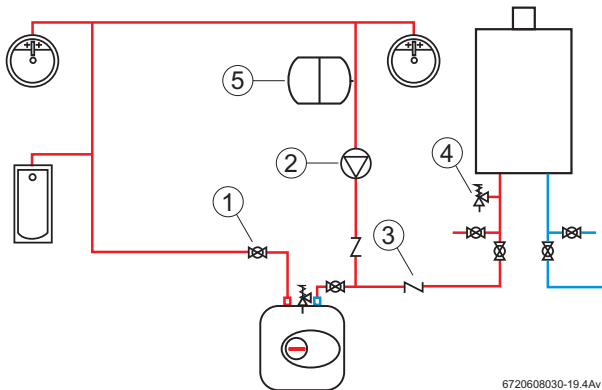

Fig. 17 Recirculation application

- 1 Full port shutoff valve
- 2 Circulator
- 3 Check valve
- 4 PRV
- 5 Expansion tank

A small electric mini tank water heater (4-6 gallon size) must be used for this application and designed so the pump will circulate the water through the mini-tank and the building's hot water return loop only. A timed or thermostatically controlled operation of the pump is commonly done. The 520 HN must be plumbed in line before the mini-tank water heater. Contact Bosch Water Heating if further instruction is needed.

## 4 Operation instructions

### 4.1 For your safety, read before operating your water heater



**Warning:** If you do not follow these instructions exactly, a fire or explosion may result causing property damage, personal injury or loss of life.

**A.** This appliance is equipped with electronic ignition for lighting the pilot and main burners. When turning the heater on, follow these instructions exactly.

**B.** Before operating the unit, set the On/Off button to the On  position. The On/Off button is located on the front panel. Smell all around the appliance area for gas. Be sure to smell next to the floor because some gas is heavier than air and will settle on the floor.



#### WHAT TO DO IF YOU SMELL GAS

- ▶ Close gas valve. Open windows.
- ▶ Do not try to light any appliance.
- ▶ Do not touch any electric switch; do not use any phone in your building.
- ▶ Immediately call your gas supplier from a neighbors phone. Follow the gas supplier's instructions.
- ▶ If you cannot reach your gas supplier, call the fire department.

**C.** Use only your hand to push in the on/off control button. Never use tools. Follow these instructions exactly. If control button is jammed, close the gas supply and call a qualified service technician. Attempted forceful repair may result in a fire or explosion.

**D.** Do not use this appliance if any part has been under water. Immediately call a qualified service technician to inspect the appliance and to replace any part of the control system and any gas control which has been under water.

## 4.2 Lighting instructions

- ▶ **1. STOP!** Read the previous safety information.
- ▶ **2.** The gas valve must be shut off by putting the ON/OFF switch to position OFF . Wait five (5) minutes to clear out any gas. If you smell gas, STOP! Follow "B" in chapter 4.1. If you do not smell gas, go to the next step.
- ▶ **3.** This water heater is equipped with a safety pilot burner and an automatic ignition control system.
- ▶ **4.** Set the ON/OFF button to the position ON . In this position, the water heater is ready to use.

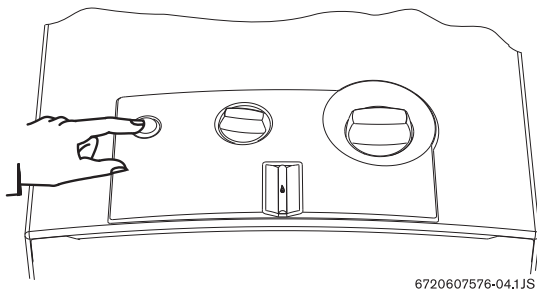



Fig. 18

- ▶ **5.** Open hot water tap to a flow rate above the minimum activation rates listed in table 4. The automatic ignition system first ignites the safety pilot burner which then ignites the main burner in about 4 seconds.
- ▶ **6.** The green LED indicator is on when the main burner is on.
- ▶ **7.** The pilot flame will extinguish a few seconds after the burners come on. The burners will remain on until the hot water tap is turned off.

**Note:** The 520 HN operates in two modes. See SETTING THE WATER TEMPERATURE.

**i** **Note: On initial installation, existence of air in the gas supply line and in the water line may cause some ignition delay. In that case, repeat the ignition process until all the air has been purged.**

## 4.3 To turn off appliance

- ▶ Set the ON/OFF switch to the position OFF .

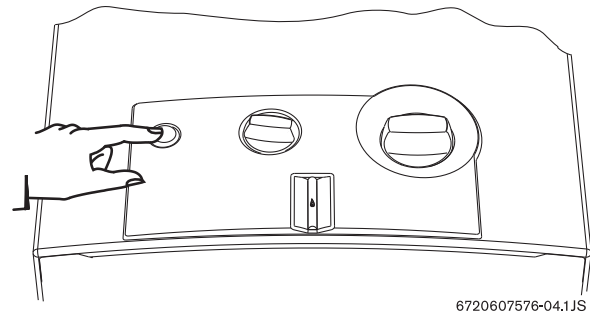

Fig. 19

- ▶ Close installer supplied manual gas shutoff valve on the supply line to the heater.

## 4.4 Adjusting the water temperature

The 520 HN has two knobs that regulate temperature. One knob controls temperature by regulating water flow through the heater. The other knob controls temperature by adjusting the gas supply to the burners.

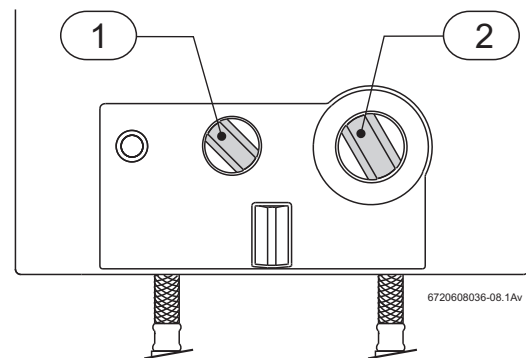

Fig. 20

- 1 Power adjustment knob
- 2 Flow control knob

### Flow control knob

The flow control knob (see Fig. 20 & Fig. 21) adjusts temperature by adjusting flow capacity. See table 4 for details.

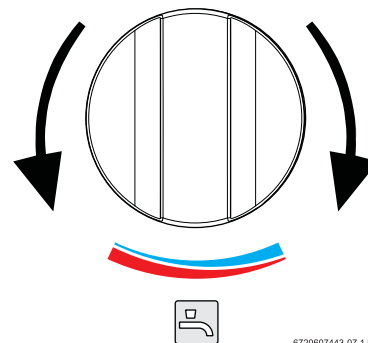

Fig. 21



- ▶ Turning the flow control knob clockwise restricts water flow. This provides higher temperature because the water is moving slower, spending more time over the burner flames. Turning flow control knob fully clockwise also lowers the activation rate (water flow needed to turn the heater on) to 0.5 gpm.
- ▶ Turning the flow control knob counter-clockwise increases water flow. This provides lower temperature because the water is moving faster, spending less time over the burner flames. Turning flow control knob fully counter-clockwise also increases the activation rate of the heater to 1.1 gpm.

Knob position	Clockwise	Counter-clockwise
Degree rise	90°F	45°F
Activation rate	0.5 GPM	1.1 GPM
Max flow rate	2.0 GPM	4.3 GPM

Table 4 Flow control knob settings

#### 4.5 Power adjustment knob

The power adjustment knob (see Fig. 20 & 22) adjusts temperature by adjusting the amount of gas supplied to the burners.

(note: change in flame height not always visible with knob adjustment).

- ▶ Turning the power adjustment knob clockwise supplies less gas to the burners and lowers the water temperature.

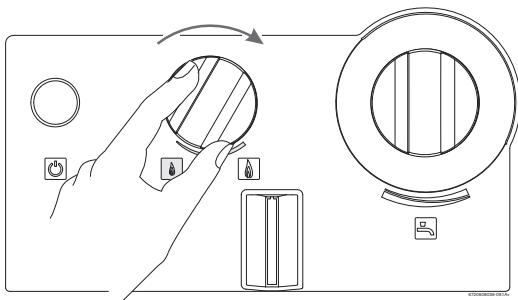

Fig. 22

- ▶ Turning the power adjustment knob counter-clockwise supplies more gas to the burners and raises the water temperature.

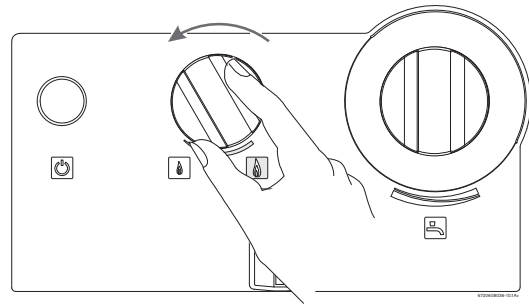

Fig. 23

#### Maximum temperature

The maximum temperature is achieved by turning the (left) power adjustment knob fully counter-clockwise and the (right) flow control knob fully clockwise.

#### 4.6 Draining the appliance

If there is a risk of freezing, proceed as follows:

- ▶ Remove the retaining clip from water valve (pos. 1).
- ▶ Remove bushing and filter (pos. 2) from water valve.
- ▶ Empty the appliance of all water.

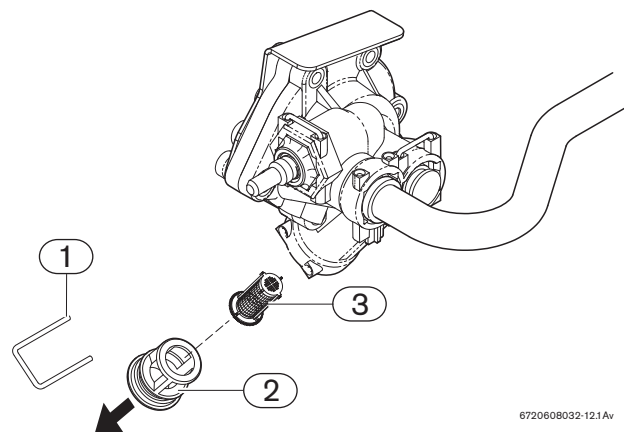

Fig. 24 Draining

- 1 Retaining clip
- 2 Threaded bushing
- 3 Filter



**Warning:** To prevent any freeze damage, introduce short bursts of compressed air (20-40psi) through the outlet water connection to remove the residual water in the horizontal pipes and water valve.



## 5 Maintenance and service

### 5.1 Maintenance intervals



**Warning:** Failure to perform recommended maintenance may result in complete failure of the unit over time. The warranty does not cover failures due to improper or insufficient maintenance.

The 520 HN requires periodic maintenance. The time maintenance intervals below should keep the unit operating for many years.

#### Every year

- ▶ Inspect inlet water filter screen ( 5.2)
- ▶ Inspect pilot assembly and flame ( 5.3)
- ▶ Inspect burner assembly ( 5.4)

#### Every 2 years

- ▶ Inspect heat exchanger fins for soot, debris or blockage. Clean if necessary (5.5)
- ▶ Clean and lubricate water valve ( 5.2)

#### Every 3 to 5 years

- ▶ Rebuild water valve with parts kit (part# WVKITCT) ( 5.2)
- ▶ Clean pilot assembly and clean or replace orifice ( 5.3)

### 5.2 Water valve

The water valve is the main control that tells the heater to fire. If the periodic maintenance is neglected, more costly damage may occur.

#### Inspecting inlet water filter screen

Shut off the installer supplied cold water shut-off valve to the heater. If one is not installed, install before proceeding. Open the nearest hot water tap to drain the plumbing lines. Position a bucket under the heater's water valve assembly to catch any water that may drain from the heater. Remove the filter retaining clip located at base of water valve (see Fig. 24). Remove the bushing to access the cylindrical filter inside. Remove filter, clean with water and inspect for damage. If the filter is damaged, it must be replaced.

#### Lubricating the water valve

Service bulletins are available on our website at [www.boschpro.com](http://www.boschpro.com). Shut off the installer supplied cold water shut-off valve to the heater. If one is not installed, install before proceeding. Open the nearest hot water tap to drain the plumbing lines. Position a bucket under the heater's water valve assembly to catch any water

that may drain from the heater. Disconnect the inlet water pipe going to the back of the water valve. Disconnect the water pipe leading out of water valve to the heat exchanger. Do this by removing the retaining clip on water valve assembly and pulling the pipe free from the water valve. Loosen the two set screws underneath the water valve where it connects to the gas valve. If the set screws are seized, STOP and call Bosch tech support before proceeding. Forcing and breaking seized set screws may damage the water valve and gas valve assemblies. Remove the water valve by pulling it to the right. Separate the two halves of the water valve by removing the five screws on the left side of the water valve. Apply lithium or faucet & valve grease to the pushrod and o-ring. (See Fig. 28, num. 4). Remove and inspect the venturi and clean if necessary. (see Fig 28, num. 23).

#### Rebuilding the water valve

Several parts within the water valve must be replaced every 3 to 5 years depending on water quality and usage. For more detailed instruction, bulletin CT-23 can be found on our website at [www.boschpro.com](http://www.boschpro.com). Failure to rebuild the water valve can result in decreased performance or water leaks in the heater.

### 5.3 Pilot

#### Inspecting pilot

The pilot should burn with a clean sharp blue flame. The flame should fully engulf the bend of the flame sensor. If it does not, clean the pilot assembly using the procedure below.

#### Cleaning pilot assembly

Shut off gas supply to the heater using installer supplied gas shutoff valve. Remove 2 screws mounting pilot burner to front of burner assembly. Remove the filter screen at the base of the pilot burner. Remove 8 mm brass hex head pilot orifice from pilot electrovalve. If heater is a NG model, soak orifice and pilot burner in carburetor cleaner for 30 minutes. Dry, blow out with compressed air and reinstall orifice. If heater is an LP model, replace orifice. Reinstall the pilot burner following removal instructions in reverse. Open gas supply and return heater to service.



**Caution:** Do not ream or poke orifice as it will enlarge orifice opening.

## 5.4 Main burners

The main burner flames should be blue, with a more intense blue cone in the center core. Yellow flames could be a sign of wrong size gas orifices, dirty burners or a blockage on the heat exchangers fins. If some burners have yellow flames while others have blue flames, it is likely that dust, lint or spider webs have partially clogged the burner venturis. To clean the burners, contact a gas service person and refer to service bulletin CT-13.

## 5.5 Vent assembly / heat exchanger

Inspect the draft hood and heat exchanger fins for signs of soot build-up or any other foreign material such as spider webs. Clean out any debris found in the vent hood and/or heat exchanger fins. Signs of soot indicate insufficient combustion air or exhaust draft. Check for vent assembly blockage or combustion air blockage on the underside of the unit.

## 5.6 Mineral scale build-up

The 520 HN, when operated at lower temperatures settings, does not accumulate mineral build-up. If however, the heater is used at higher temperature settings and the water has a high mineral content, mineral deposits (scale) may form within the heat exchanger and periodic descaling may be necessary. The heat exchanger should be flushed with a descaling solution.

### 5.6.1 Descaling heat exchanger

1. Shut off the water supply to the water heater using (installer supplied) shut-off valve.
2. Open hot water taps to drain and relieve pressure from the plumbing system.
3. Drain water from the unit by disconnecting inlet and outlet water connections.
4. Connect the line (A) from the outlet of the circulating pump (installer supplied) to the inlet water fitting on the water heater.
5. Using another line (B), connect to the water outlet fitting on the water heater. Route the other end of this line into a descaling reservoir.
6. Using a 3rd line (C) from the descaling reservoir, connect to the inlet side of circulating pump. Install a filter on the end of the line in the descaling reservoir.
7. Make sure all connections are "hand tight."
8. Fill tank with descaling solution so lines inside are submersed. We recommend a straight white vinegar solution. If using a commercial descalant, refer to manufacturer's instructions on dilution with water.
9. Operate the circulating pump.

10. Make sure there are no leaks and the solution is flowing from the descaling reservoir through the heat exchanger and returning to the reservoir.

11. Run solution through the heat exchanger until the solution returning to the descaling reservoir comes out clear.

- ▶ Changing to a fresh solution may be necessary during this process.
- ▶ Several hours may be necessary to flush the heater thoroughly.

12. Disconnect all lines and drain all solution from heat exchanger. Properly discard of solution.

13. Position a container below the hot water outlet and connect cold water supply. Open cold water supply shut-off valve and flush heater with clean water.

14. Shut cold water shut-off valve and reconnect hot water supply to the water heater.

15. Open open water shut-off valves, and return the unit to service.

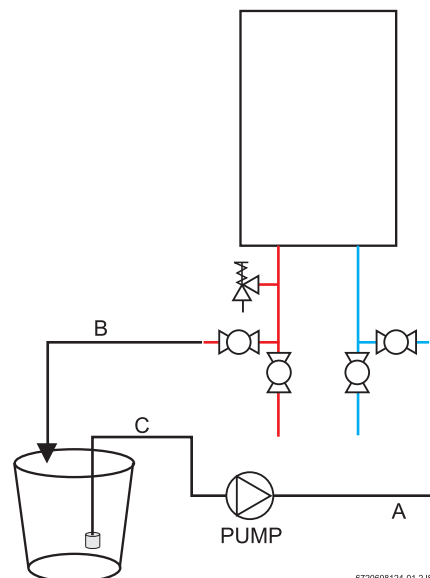

Fig. 25

## 6 Troubleshooting

### 6.1 Introduction

Many of the questions customers ask regarding operation of this unit can be answered by following the troubleshooting steps as outlined below. Visit our web site at [www.boschpro.com](http://www.boschpro.com) for more detailed troubleshooting bulletins. For best results, perform each step before proceeding to the next. The suggested solutions may require that the cover be taken off. (See chapter 3.5).

### 6.2 No spark at pilot with water flow

Refer to service bulletin CT-09

- 1. Ensure that the On/Off button on control box is pushed to the "On" position. .
- 2. Ensure that cold water supply is attached to rear of water valve and hot water outlet is on the left.
- 3. Measure voltage at hydrogenerator. Disconnect the wire connector at hydrogenerator and measure voltage on hydrogenerator side of connector.
  - a. If the wires from the hydrogenerator are black and red, the voltage should be at least 1.3VDC.
  - b. If the wires from the hydrogenerator are blue and brown, the voltage should be at least 2.8VAC. If the voltage is inadequate, refer to bulletin CT-29 to clean the hydrogenerator.
- 4. Check for crossover:
  - a. Turn off cold water supply to heater only. If no shut off valve is present, install before continuing.
  - b. Turn on each hot water fixture to hot only.
  - c. Wait 5 minutes.
  - d. If any water is flowing, even a trickle, there is a crossover or the scald protection in a shower valve is adjusted incorrectly. Consult plumber or faucet valve manufacturer for repair or adjustment.
- 5. Rotate flow control (right knob) to full clockwise position for the lowest activation rate of about .6 gallon per minute. As the knob is turned counter-clockwise, the activation rate will rise to about 1.1 gallons per minute.
- 6. Check for obstructions to water flow. Clean inlet filter screen in water valve, whole house filters, showerheads and faucet aerators. Obstructions such as dirt, debris or mineral deposits will decrease the water flow through the heater below the activation rate.
- 7. Check for tight and clean wire connections in heater:
  - a. wire from ignition unit to spark electrode
  - b. wires to flue gas sensor on draft diverter
  - c. wires to overheat sensor on outlet pipe
  - d. wires to overheat sensor on heat exchanger

- e. wires to microswitch
- f. ground wire connection between ignition unit and fixing screw
- 8. If a powervent and spill switch are installed, check the reset button on the spill switch (installed on the draft diverter). Consult powervent manual for more details.
  - a. If the button clicks when pushed, the switch was tripped. Check venting for restrictions and exhaust hood damper for correct operation.
- 9. Check microswitch on bottom of gas valve. Disconnect wire connector at microswitch and jump connector on wiring cable. Run water through heater.
  - a. If heater sparks, check continuity through microswitch connector with water flow. If circuit does not close one of the following may be the cause; microswitch is faulty, water valve needs maintenance or flow is inadequate.
- 10. If heater still does not spark, contact Bosch technical support.

### 6.3 Spark appears when hot water is turned on, but pilot and burners will not ignite

Refer to service bulletin CT-10

If there is a spark from the spark electrode with water flow, but the pilot does not ignite:

- With water flowing and heater sparking, apply flame from a match or lighter to the rear of the pilot burner. Avoid applying flame to flame sensor.

If main burners only light, repeat procedure and watch for brief flame from pilot burner:

- 1. If pilot does not light:
  - a. Measure voltage between pilot electrovalve wire connection and ground when heater is sparking (Do not disconnect wire); Voltage must be at least 1.1VDC. If less, contact Bosch Tech Support.
  - b. Clean or replace pilot orifice. See Bulletin CT-22.
  - c. If heater has never fired, check for correct gas type on rating label on right side of cover. If incorrect, exchange heater for correct gas type. It is not practical to convert a heater to a different gas type.
  - d. If heater has never fired or gas lines have recently been serviced, there may be air in the gas line. Turn water on, wait until sparking has stopped, turn water off and back on again. Repeat until pilot lights or have gas technician bleed the gas line.

- e. Verify that gas shut off valves are open. Gas must be supplied to heater.
  - f. Measure gas pressure at inlet tap with manometer. See service bulletin CT-04.
  - g. If no gas is present, Maxitrol regulator supplied with heater may be upside down or locked. Reinstall correctly or unlock regulator (see Bulletin CT-14). Measure gas pressure on gas line before Maxitrol. If over 14", Maxitrol should lock up to prevent high gas pressure from damaging heater.
  - h. Check for tight and clean wire connections to pilot and burner electrovalves. Remove connector and clean with pencil eraser if dirty or corroded.
  - i. Check pilot electrovalve function: Turn off gas supply to heater, remove wire connection from electrovalve, connect positive terminal from a single cell battery (1.2-1.5VDC) to electrovalve terminal and a jumper wire from negative terminal of battery to ground. When connection is complete, there should be an audible "click" from the electrovalve. If no click is heard, electrovalve may be faulty.
- 2. If pilot and burners light:
    - a. Check for drafts around pilot burner. See Bulletin CT-03 but apply smoke to pilot burner without heater operating. If smoke is blown away from pilot burner, find cause of draft and correct.
    - b. If an AQ4 powervent is installed:
      - I. Check for presence of time delay in powervent. If there is no time delay, replace with newer style AQ4 powervent with time delay.
      - II. If powervent has time delay, check for correct setting (2 seconds).
      - III. Check for adequate minimum vent length. Refer to AQ4 Installation Manual.

### 6.4 Pilot lights, but burners will not come on.

1. Verify that gas type indicated in the rating sticker located on the cover's right hand side, coincides with the gas type you are using. NG is a natural gas unit and LP is for liquid propane (See chapter 2.2).
2. Pilot flame should be blue in color and completely engulfing the flame sensor. If not, the pilot orifice may be dirty or clogged. See chapter 5.3 on how to clean the pilot and orifice.
3. If sparking does not stop when pilot is lit, the flame sensor may not be recognizing pilot flame. Verify that wire connection clip on wire from the bottom of the flame sensor is secure. If flame sensor is fully engulfed by the pilot flame, it may be dirty. Clean entire surface area of flame sensor with a pencil eraser or fine steel wool.
4. Confirm that wire connection to the burner electrovalve is secure (see components diagram for

location of burner electrovalve). Inspect terminals for corrosion. To clean terminals, remove the spade connectors and clean with a pencil eraser.

5. Ignition unit, burner electrovalve or flame sensor maybe faulty. Measure voltage from the spade connection of the burner electrovalve to ground with wire connected (see components diagram for location of burner electrovalve). After the pilot lights, voltage should read at least 1 VDC. If voltage is proper, the burner electrovalve may be faulty. If voltage is not proper, ignition unit may be faulty.

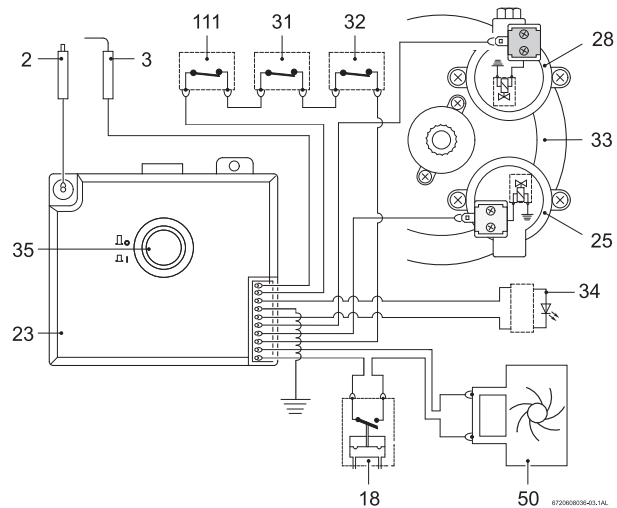

Fig. 26 Electrical wiring diagram

2	Spark electrode
3	Flame sensor
18	Microswitch
23	Ignition unit
25	Burner electrovalve
28	Pilot electrovalve
31	Temperature limiter/ECO
32	Flue gas sensor
33	Gas valve
34	Main burner operation LED
35	On/Off button
50	Hydrogenerator
111	Temperature limiter/ECO

### 6.5 Main burners go out during hot water use

1. Hot water flow rate is dropping below required activation flow rate. Turn flow control knob all the way clockwise. Fully open a hot water faucet and fill a quart container. If the container fills in 36 seconds or less, the flow rate (0.5 gallon per minute) is sufficient to activate the water heater. If flow rate is not sufficient, the water heater's inlet filter should be inspected and cleaned. See chapter 5.2.
2. Close installer supplied cold water shut off valve (if none installed, install before proceeding). Open every hot water tap supplied by the heater. Wait 5 minutes and check all taps. Any water running, even a trickle, is a sign of a plumbing crossover. Consult local plumber

or service person for help correcting a plumbing crossover.

3. The minimum water pressure required is 30psi. For installation on a well system with use of a pressure tank, the lowest pressure range setting recommended is 30-50 psi (2.07-3.45 bar).

4. Hot water is very hot out of the tap, requiring a lot of cold water to be added to it in order to attain a useable hot water temperature. The addition of too much cold water will slow the flow within the tankless heater, decreasing it below activation point, which shuts off the burners. The end result is nothing but cold water coming out of the outlet. Reduce the amount of cold water to be mixed by turning the gas control knob clockwise for lower hot water temperatures. See chapter 4.4 for details in lowering temperature.

5. A temperature limiter (ECO) is tripped. The water heater does not have a thermostat. If the inlet water is preheated, the unit will overheat, stopping the flow of gas. Supply heater inlet with cold water only.

6. Flue gas sensor is tripped. Lack of adequate combustion air or venting improperly by reducing pipe diameter, improper use of elbows or exceeding maximum vent length will trip the flue gas sensor. Confirm that venting and combustion air meet requirements in this manual. Refer to service bulletin CT-03.

7. If the water has a high mineral content, the heat exchanger may be scaled internally. This restricts the water path, causing the water to overheat and trip the temperature limiter (ECO). To descale the heat exchanger, consult section 5.6 on page 18.

8. The water valve assembly, which allows gas flow to the burners, requires periodic maintenance (every 2-5 years depending on water quality and use). See section 5.2.

## 6.6 Hot water temperature fluctuates at tap

1. Close installer supplied cold water shut off valve (if none installed, install before proceeding). Open every hot water tap supplied by the heater. Wait 5 minutes and check all taps. Any water running, even a trickle, is a sign of a plumbing crossover. Consult local plumber or service person for help correcting a plumbing crossover.

2. Check for a clogged inlet water filter screen. See chapter 5.2.

3. Hot water is very hot out of the tap, requiring a lot of cold water to be added to it in order to attain a useable hot water temperature. The addition of too much cold water will slow the flow within the tankless heater, decreasing it below activation point, which shuts off the burners. The end result is nothing but cold water coming out of the outlet. Reduce the amount of cold water to be mixed by turning the gas control knob

clockwise for lower hot water temperatures. See chapter 4.5. If the problem persists, go to [www.boschpro.com](http://www.boschpro.com) for service bulletin CT-07.

4. The water heater is designed to modulate gas flow to the burners when water flow varies. If the water pressure in the home is erratic and the water flow is not consistent while a tap is opened, then the temperature of the hot water will fluctuate. The minimum water pressure for the home must be 30psi or greater. For installations on a private well system with the use of a pressure tank, the lowest pressure range setting recommended is 30-50psi (2.07-3.45 bar). The use of a pressure reducing/regulating valve before the water heater (directly after the pressure tank on well systems) may be an effective way to maintain constant water pressure to the water heater.

5. If the inlet water temperature is not consistent then the hot water temperature from the water heater will fluctuate. The water heater modulates its burners when flow rate is changed. It does not have a thermostat and will not adjust to changes in inlet water temperature.

6. If the inlet water temperature to the water heater is above 70 F, the heater may produce outlet temperatures that are too hot for most uses. A temperature balance shower valve can automatically mix in cold water to reduce very hot water temperatures. This can slow the flow within the tankless water heater, decreasing it below activation point, which shuts off the burners. In the event of any temperature instability with the use of a temperature balance shower valve, refer to shower valve manufacturer instructions for internal adjustment to minimize the amount of cold water the valve is adding.

7. The gas pressure also needs to be stable and adequate. Ensure that gas pressure meets specifications in chapter 3.8. A gas pressure reading is needed to proceed further. Contact your original installer or a local gas technician to obtain this reading.

## 6.7 Water is too hot

1. Verify that gas type indicated in the rating sticker located on the cover's right hand side coincides with the gas type you are using. NG is a natural gas unit and LP is for liquid propane (See chapter 2.2).

2. Adjust the power adjustment knob clockwise for cooler temperatures. See section 4.4.

3. Inlet water is preheated. This model does not have a thermostat and will not modulate flame height in order to prevent overheating. It is designed for cold water supply only. Supply the heater with cold water to the inlet.

4. Increase flow rate. Restrictions in the water path can slow the flow of water through the heater, resulting in very hot outlet temperatures. Restrictive showerheads and faucet aerators should be cleaned or upgraded with less restrictive ones. In addition, the inlet filter on

the water heater should be cleaned and inspected. See chapter 5.2.

5. If the water has a high mineral content, the heat exchanger may be scaled internally. This restricts the water path, causing the water to boil and produce extremely hot temperatures. To descale the heat exchanger, section 5.6 on page 18.

### 6.8 Water is not hot enough

1. Verify that gas type indicated in the rating sticker located on the cover's right hand side coincides with the gas type you are using. NG is a natural gas unit and LP is for liquid propane (see chapter 2.2).

2. Flow at one particular tap is too great or too many fixtures are running at one time. Lower flow to stay within the heater's specifications.

3. Ensure that the gas control knob is all the way counter-clockwise for highest temperatures. In addition, the flow control knob maybe set too high. Raise the setting by turning the knob clockwise for higher temperatures.

4. Close installer supplied cold water shut off valve (if none installed, install before proceeding). Open every hot water tap supplied by the heater. Wait 5 minutes and check all taps. Any water running, even a trickle, is a sign of a plumbing crossover. Consult local plumber or service person for help correcting a plumbing crossover.

5. Inspect the water path outside the heater for obstructions. Make sure all showerheads, faucet aerators and whole house filters are clear of debris. Also, the water heater's inlet filter should be inspected and cleaned. See chapter 5.2.

6. The water valve assembly, which allows gas flow to the burners, requires periodic maintenance (every 2-5 years depending on water quality and use). See section 5.2.

7. Gas pressure is too low. Ensure that gas pressure meets specifications meets chapter 3.9. A gas pressure reading is needed to proceed further. Contact your original installer or a local gas technician to obtain this reading.

### 6.9 Low hot water pressure

1. Confirm adequate flow rate through the unit. With cold supply shut off to the unit, disconnect hot outlet side to the unit. Place a gallon jug under hot water outlet to catch water. Open cold water supply and measure flow rate out of the unit. With temperature adjustment knob set all the way clockwise, the flow rate should be close to 2GPM (filling the jug in 30 seconds or less). If the flow rate is not adequate, inspect and clean inlet filter screen. See chapter 5.2.

2. Confirm that the incoming water pressure to the unit is above the minimum required pressure of 30psi.

3. Inspect the water path outside the heater for obstructions. Make sure all showerheads, faucet aerators and whole house filters are clear of debris.

4. Be sure to run only one major fixture at a time with this water heater. Opening too many taps at one time can disperse water flow resulting in diminished flow or pressure at all outlets.

### 6.10 Noise when heater is running

If the water has a high mineral content, the heat exchanger may be scaled internally. This restricts the water path, causing the water to boil resulting in noise and overheating. To descale the heat exchanger, consult section 5.6 on page 18.

### 6.11 Burners do not burn cleanly, yellow flames when operating

1. Verify that gas type indicated in the rating sticker located on the heater's right hand side, coincides with the gas type you are using. NG is a natural gas unit and LP is for liquid propane (see chapter 2.2).

2. For proper combustion at high elevations the inlet gas pressure must be set at installation to the values in table 3 on page 11 (while operating at maximum BTU). A gas pressure reading is needed to proceed further. Contact your original installer or a local gas technician to obtain this reading.

3. Combustion air is inadequate. Ensure that adequate combustion air is being supplied to the unit in accordance with requirements in the installation manual. See chapter 3.3.

4. Verify that the water heater is vented properly. Ensure that the venting meets requirements in chapter 3.6.

5. If the burner flames burn yellow or orange the burners must be removed from the unit and cleaned. Once the burners are removed, the fins in the top of the heat exchanger can be accessed from below and brushed or vacuumed clean. Consult service bulletin CT-13 on [www.boschpro.com](http://www.boschpro.com) for removing and cleaning the burners.

## 7 Protecting the environment

### Packing

The packing box may be fully recycled as confirmed by the recycling symbol .

### Components

Many parts in the heater can be fully recycled in the end of the product life. Contact your city authorities for information about the disposal of recyclable products.

### Saving water resources:

- ▶ Make sure you close all the taps after any use. Avoid leaving the taps dripping. Repair any leaking tap.
- ▶ Define the temperature you want. This way you have the precise water flow needed (mixing cold water to regulate temperature will increase the water flow with consequent waste of water).

**For increased safety shut off the appliance from the main water supply if you are staying away from home for a considerable time.**

**See Section 4.6.**

## 8 Interior components and diagram parts list

### 8.1 Interior components

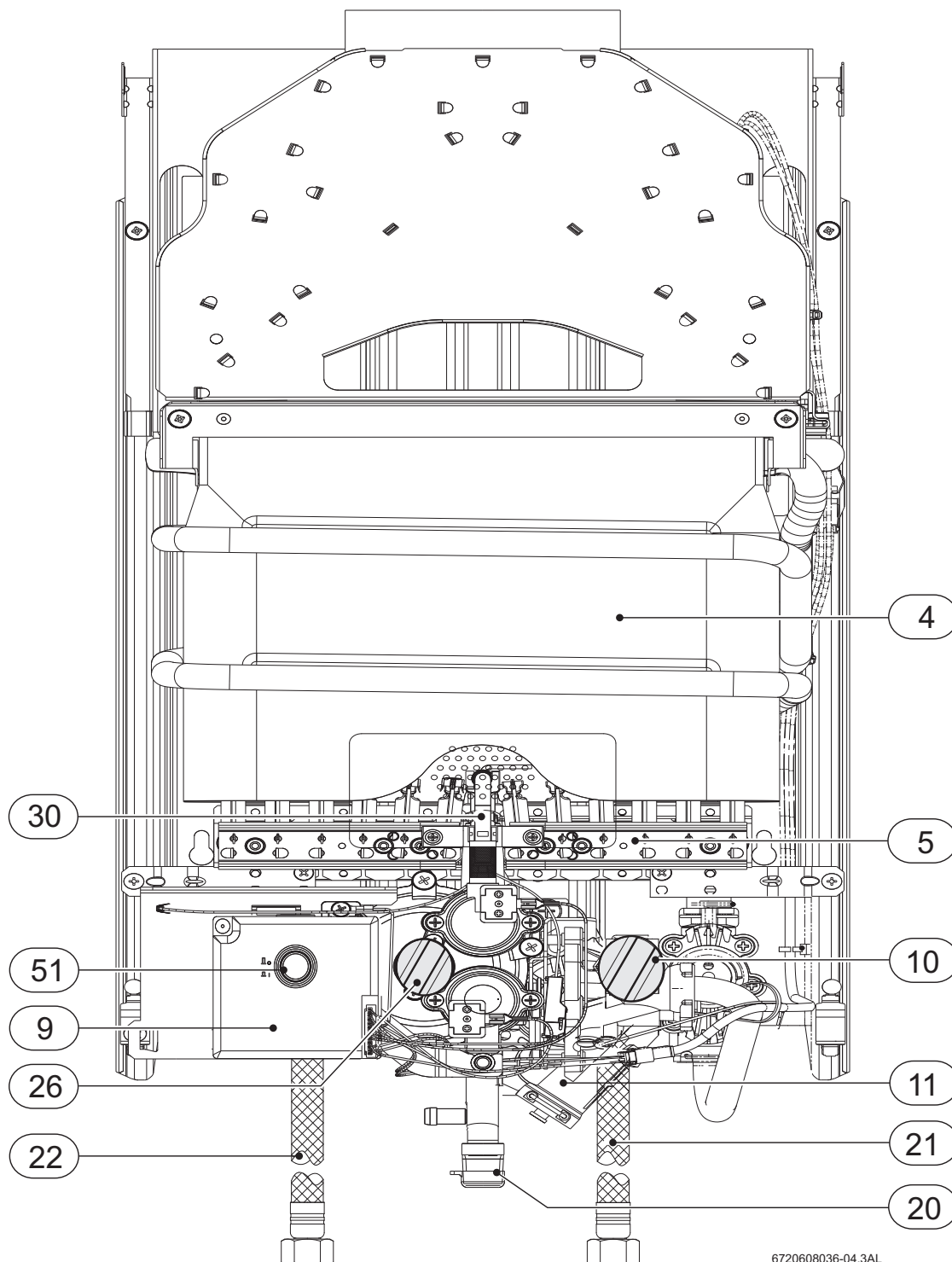

6720608036-04.3AL

Fig. 27 Functional scheme

4	Heat exchanger	22	Flexible hot outlet
5	Burner	26	Power adjustment knob
9	Ignition unit	30	Pilot burner
10	Flow control knob	51	on/off button
11	Water valve		
20	Gas connection		
21	Flexible cold inlet		



## 8.2 Components diagram

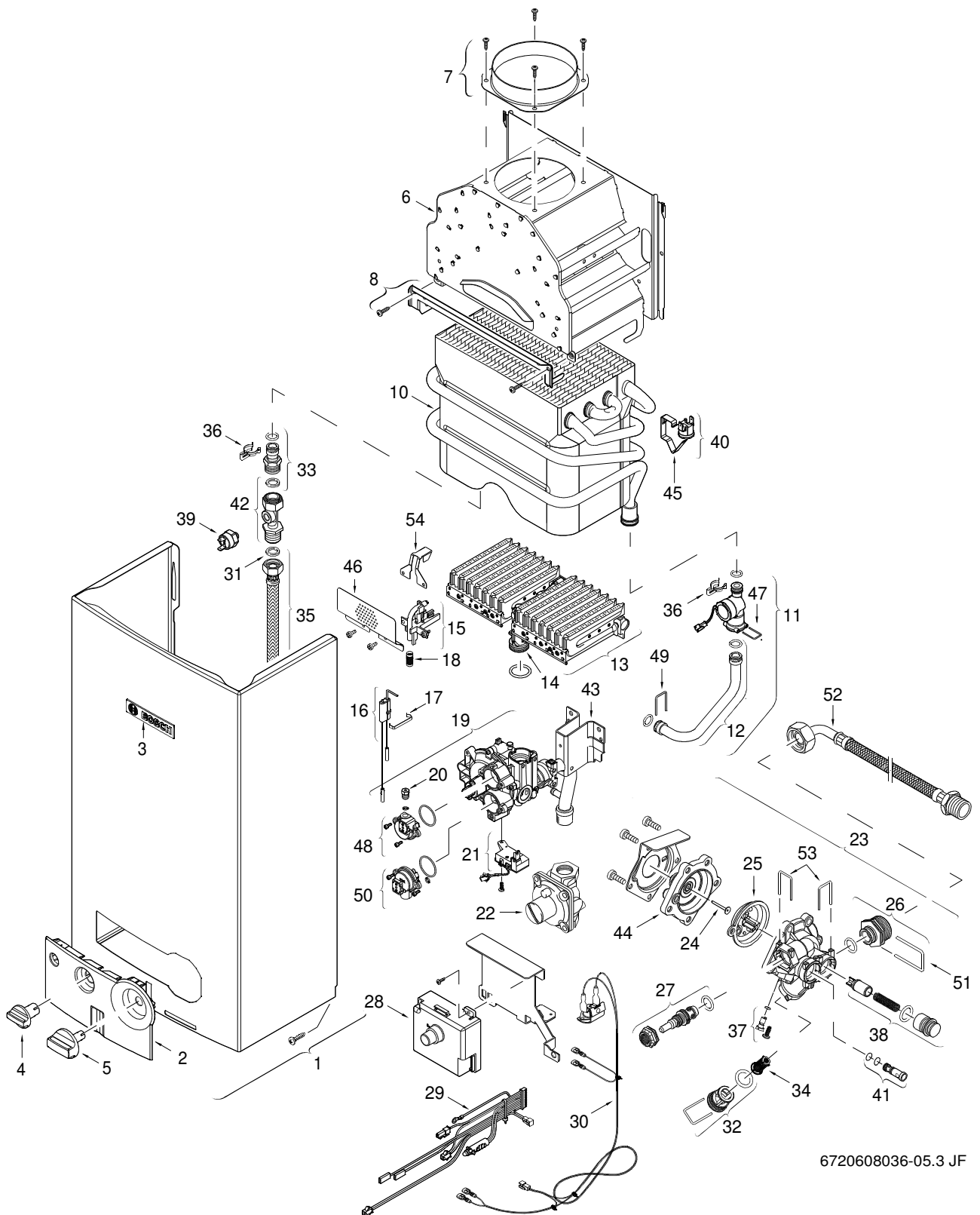

Fig. 28 Components Diagram

### 8.3 Parts list

Item	Description	Reference
1	Front cover	8 705 431 415 0
2	Shield	8 705 506 912 0
3	Trade mark badge	8 701 103 135 0
4	Flow control knob	8 702 000 297 0
5	Power adjustment knob	8 702 000 295 0
6	Draft Diverter	8 705 505 442 0
7	Exhaust pipe union Ø128	8 705 504 046 0
8	Angle bracket	8 708 003 192 0
10	Heat exchanger	8 705 406 386 0
11	Hydrogenerator	8 707 406 095 0
12	Cold water pipe	8 700 715 109 0
13	Main burner NG	8 708 120 620 0
13	Main burner LP	8 708 120 621 0
14	Connector	8 705 209 056 0
15	Pilot burner	8 708 105 655 0
16	Electrode/sensor group	8 708 107 013 0
17	Ignitor bracket	8 701 300 010 0
18	Pilot screen	8 700 507 066 0
19	Gas valve LP	8 707 011 922 0
19	Gas valve NG	8 707 021 011 0
20	Pilot orifice LP	8 708 200 321 0
20	Pilot orifice NG	8 708 200 322 0
21	Microswitch	8 707 200 020 0
22	Gas pressure regulator LP	8 707 406 083 0
22	Gas pressure regulator NG	8 707 406 084 0
23	Water valve	8 707 006 344 0
24	Water valve pushrod	8 703 204 051 0
25	Diaphragm	8 700 503 084 0
26	Inlet water connection	8 700 306 110 0
27	Selector screw	8 708 500 304 0
28	Ignition unit	8 707 207 272 0
29	Cable	8 704 404 060 0
30	Flue gas sensor	8 707 206 446 0
31	Heat exchanger washer	8 700 103 658 0
32	Threaded bushing	8 700 306 148 0
33	Connector	8 700 306 187 0
34	Water Filter	8 700 507 059 0
35	Outlet Hose	8 700 703 139 0
36	Water connection clip	8 701 201 020 0
37	Plunger	8 703 502 039 0
38	Volumetric water governor	8 705 705 034 0
39	ECO/temperature limiter	8 707 206 017 0
40	Temperature limiter/ECO	8 707 206 435 0
41	Venturi	8 708 205 279 0
42	Hot water pipe	8 700 705 178 0
43	Gas supply pipe	8 700 715 351 0
44	Cover	8 705 500 105 0
45	Clip	8 701 300 015 0
46	Protection shield	8 701 000 397 0
47	Wire form spring	8 704 705 030 0
48	Pilot valve	8 708 501 249 0
49	Wire form spring	8 704 705 025 0
50	Servovalve	8 708 501 250 0
51	Wire form spring	8 704 705 024 0
52	Inlet Hose	8 700 703 114 0
53	Wire form spring (10x)	8 704 705 029 0
54	Protection shield	8 701 000 414 0

Table 5

## 9 Fifteen Year Limited Warranty

### General

BOSCH heaters are warranted by the Manufacturer (BOSCH) through Bosch Thermotechnology. Bosch Thermotechnology will furnish a replacement heat exchanger and will furnish a replacement of any other part which fails in normal use and service within the applicable periods specified below, in accordance with the terms of this warranty. The replacement will be warranted for the unexpired portion of the original warranty. This warranty will be valid only for water heaters in possession of the original purchaser as recorded on the warranty card.

### The Heat Exchanger

If the heat exchanger fails within fifteen (15) years after the original installation and operation *Bosch Thermotechnology Corporation* will furnish a replacement heat exchanger. However, if the water heater is installed in other than a single family dwelling this heat exchanger warranty is limited to three (3) years from date of original installation and operation.

### Exceptions

This warranty will not apply:

- **1.** to defects or malfunctions resulting from failure to properly install, operate or maintain the unit in accordance with the printed instructions provided;
- **2.** to damage or abuse, accident, neglect or freezing and other acts of nature;
- **3.** to damage resulting from operation with either the flame sensor rod or overheat sensor removed;
- **4.** to failure of the heat exchanger resulting from the operation of the water heater in a corrosive atmosphere or at water temperatures exceeding the maximum rating, or if the water heater is not supplied with potable water;
- **5.** to defects or damage cause by any attachment or modification, including any energy-saving device
- **6.** to damage resulting from scale deposits and/or highly mineralized / unsoftened water supply.

### All Other Parts

If any other part fails within three (3) years after original installation and operation, *Bosch Thermotechnology Corporation* will furnish a replacement part free of charge.

### Shipping costs

In addition to supplying the replacement part(s), *Bosch Thermotechnology Corporation* will provide ground service delivery for these parts. Expedited or upgraded shipping will be charged to the customer.

### Service Labor Costs

This warranty does not cover any labor costs associated with service, removal or re-installation of part(s). All such costs must be borne by the Purchaser. Additionally, this warranty does not cover any labor costs associated with service, removal or re-installation of the original water heater or a replaced water heater.



Note: the water heater must be free of damaging scale deposits and not subject to gas pressures greater than those shown on the rating plate, which must not be altered, defaced or removed.

### How to Make a Claim

Any claim for warranty parts should be made to your local dealer or distributor:

### BOSCH THERMOTECHNOLOGY CORPORATION

50 Wentworth Avenue

Londonderry, NH 03053

Phone: 866-330-2730

www.boschpro.com

In most cases, the dealer or distributor will be able to promptly honor your claim and subsequently notify *Bosch Thermotechnology Corporation*. However, all replacements are made subject to validation by *Bosch Thermotechnology Corporation* of in-warranty coverage. The damaged or defective item must be made available in exchange for the replacement.

### Miscellaneous

No one is authorized to make any other warranties on behalf of *Bosch Thermotechnology Corporation*. It is expressly understood that the replacement warranty of *Bosch Thermotechnology Corporation* shall be in lieu of any and all other warranties, express or implied, including warranties of merchantability or fitness for a particular use or purpose, and further that *Bosch Thermotechnology Corporation* shall not be liable for any loss or damage directly or indirectly arising from the use of the hot water heater, or for any consequential damages arising from such use (including damages from water leakage). *Bosch Thermotechnology Corporation* sole liability with respect to any defect shall be for the replacement of the defective part(s). Some states do not allow such limitations and exclusions, so the above may not apply to you.

This warranty gives specific legal rights. You may also have other rights which vary from state to state.



6720644942

### Installer Checklist, to be performed by installer upon installation

Serial Number \_\_\_\_\_  
(8 digit serial number is located on rating plate on right side panel)

Gas Pressure Reading\*                      Static \_\_\_\_\_                      Operating \_\_\_\_\_

Building Water Pressure                      \_\_\_\_\_ Range if on Well system \_\_\_\_\_

Average Winter Temperature                      \_\_\_\_\_

Average Summer Temperature                      \_\_\_\_\_

Installing Company                      \_\_\_\_\_

Installer name                      \_\_\_\_\_

Address                      \_\_\_\_\_

Phone                      \_\_\_\_\_

\* See Chapter 3.7 and gas pressure table (to be filled out by installer)

Installation manual should be left with the owner after the installation is tested and completed

**BOSCH THERMOTECHNOLOGY CORP.**

50 Wentworth Avenue  
Londonderry, NH 03053  
Tel. 866-330-2730  
www.boschpro.com

Bosch Termotecnologia SA  
Estrada de Cacia  
3800 - 533 Cacia - PORTUGAL