

HVAC Security Bracket

side 1

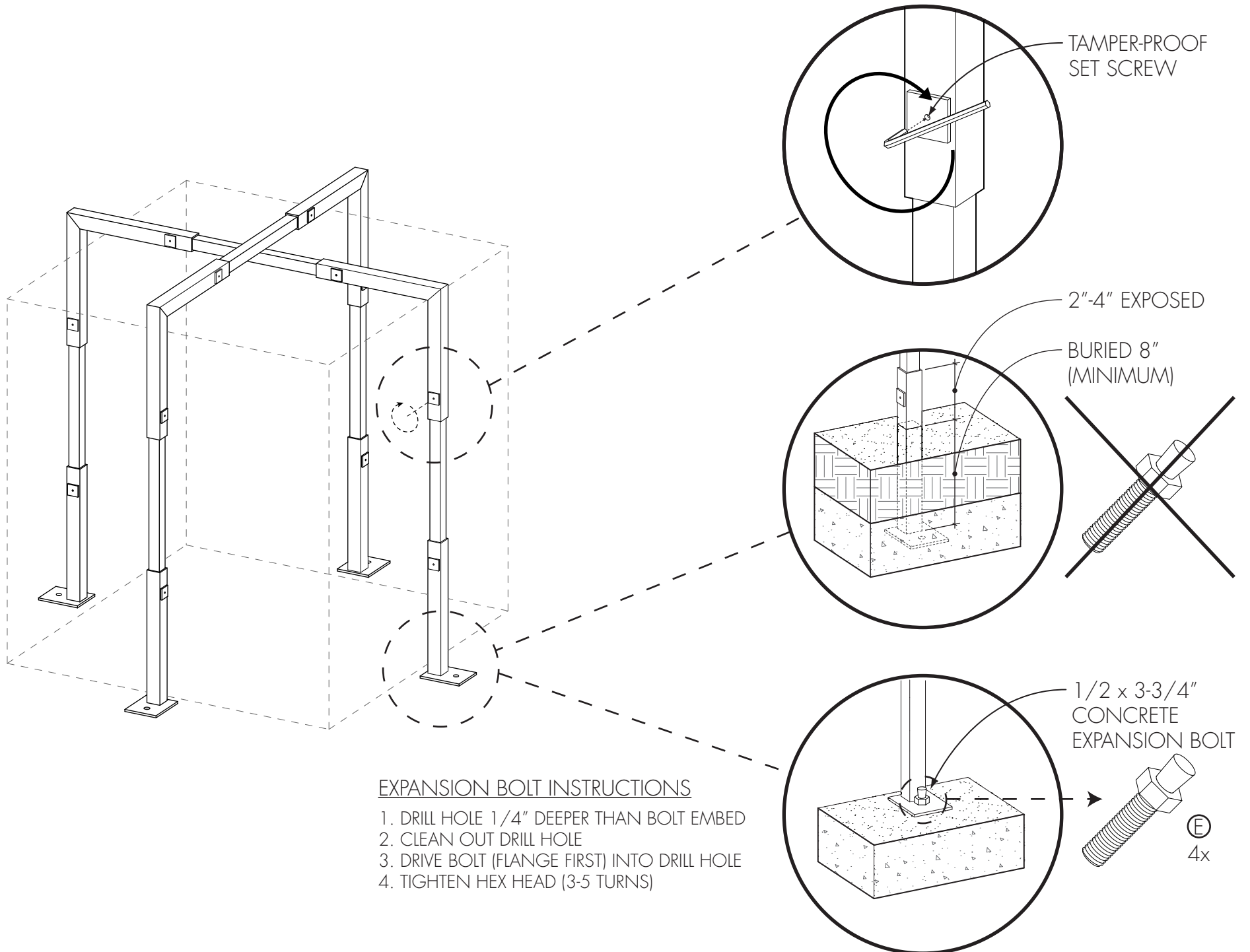

EXPANSION BOLT INSTRUCTIONS

1. DRILL HOLE 1/4" DEEPER THAN BOLT EMBED
2. CLEAN OUT DRILL HOLE
3. DRIVE BOLT (FLANGE FIRST) INTO DRILL HOLE
4. TIGHTEN HEX HEAD (3-5 TURNS)