

CESSNA 185 PARTS SHEET

Use this guide to help find and locate parts

Some parts on the sheets shown are grayed out because some

wing parts are also located on some fuselage sheets and visa versa.

For example, see and compare FUES PARTS SHEET-5 (pg 5) & WING PARTS SHEET-21 (pg 21)

FUES PARTS -----SHEET-1 thru SHEET-12

TAIL PARTS -----SHEET-13 thru SHEET-15

WING PARTS -----SHEET-16 thru SHEET-21

MISCH PARTS -----SHEET-22 and SHEET-23

OPTIONAL VORTEX WING TIPS-----SHEET-24

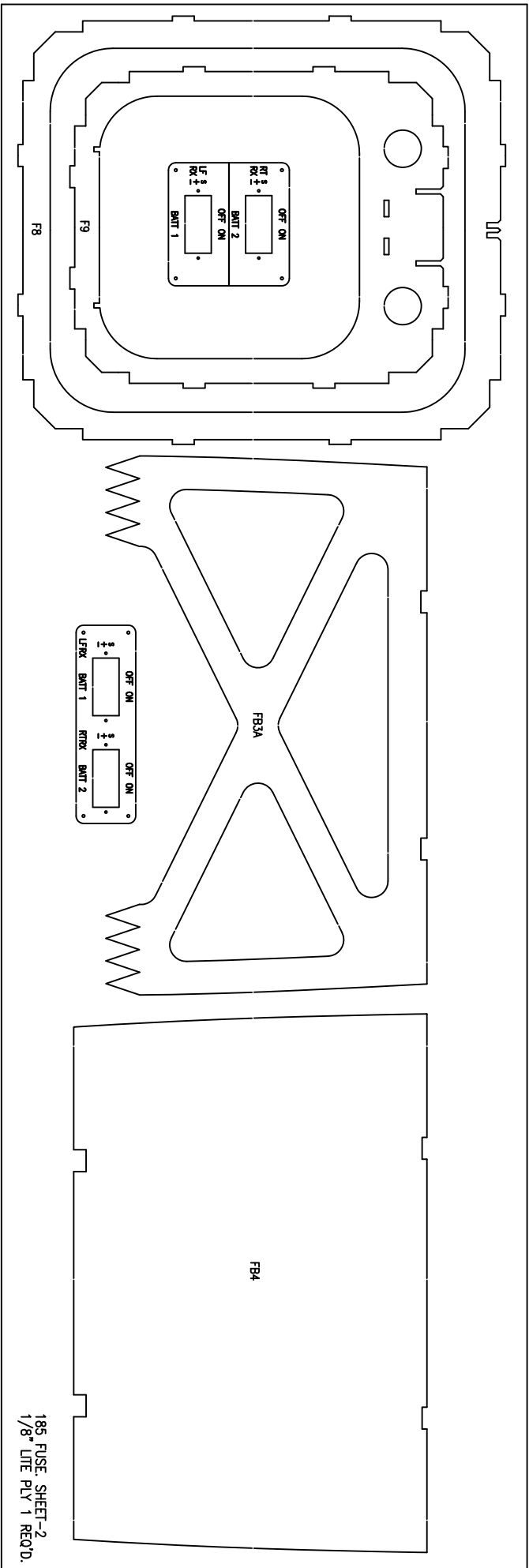
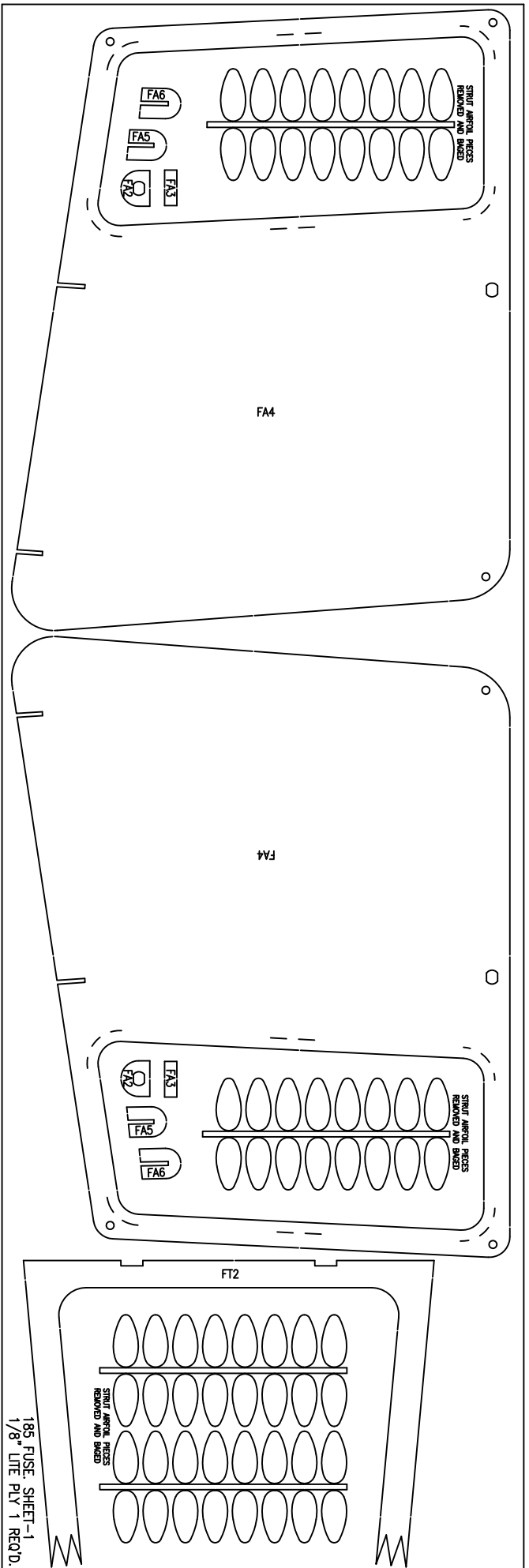

12" WIDE x 36" LONG x 1/8" THICK LITE PLY ONE (1) REQUIRED

185 FUSES PARTS SHEET-1

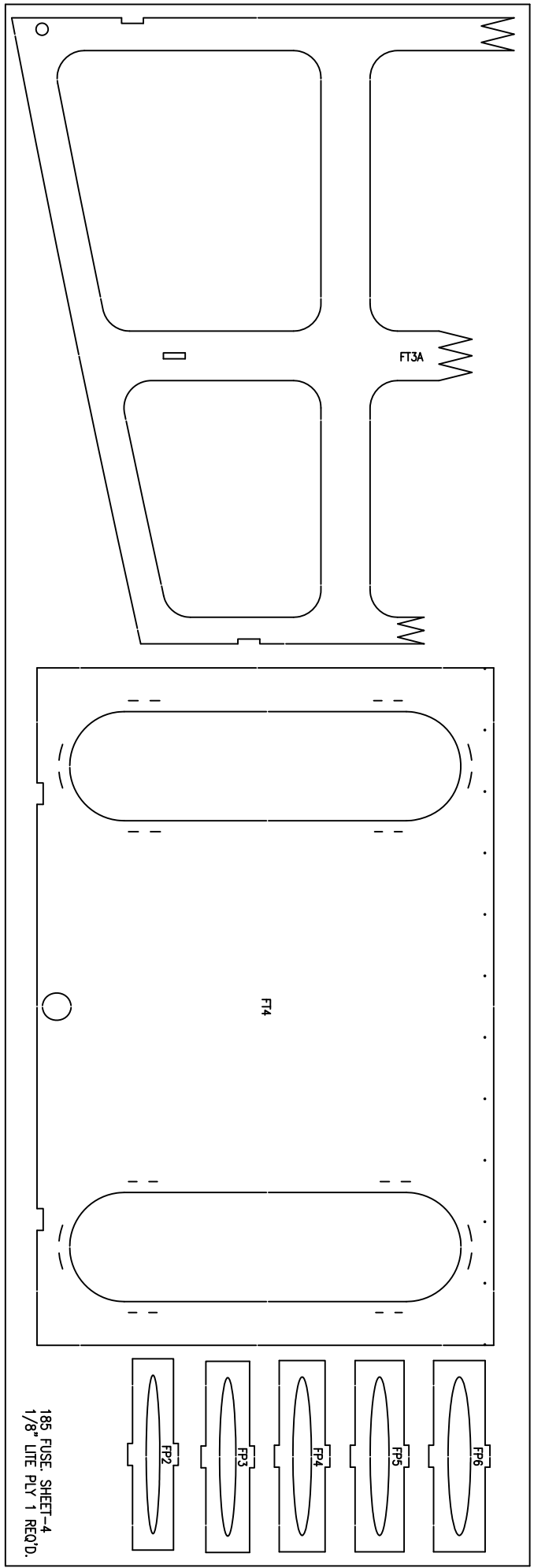
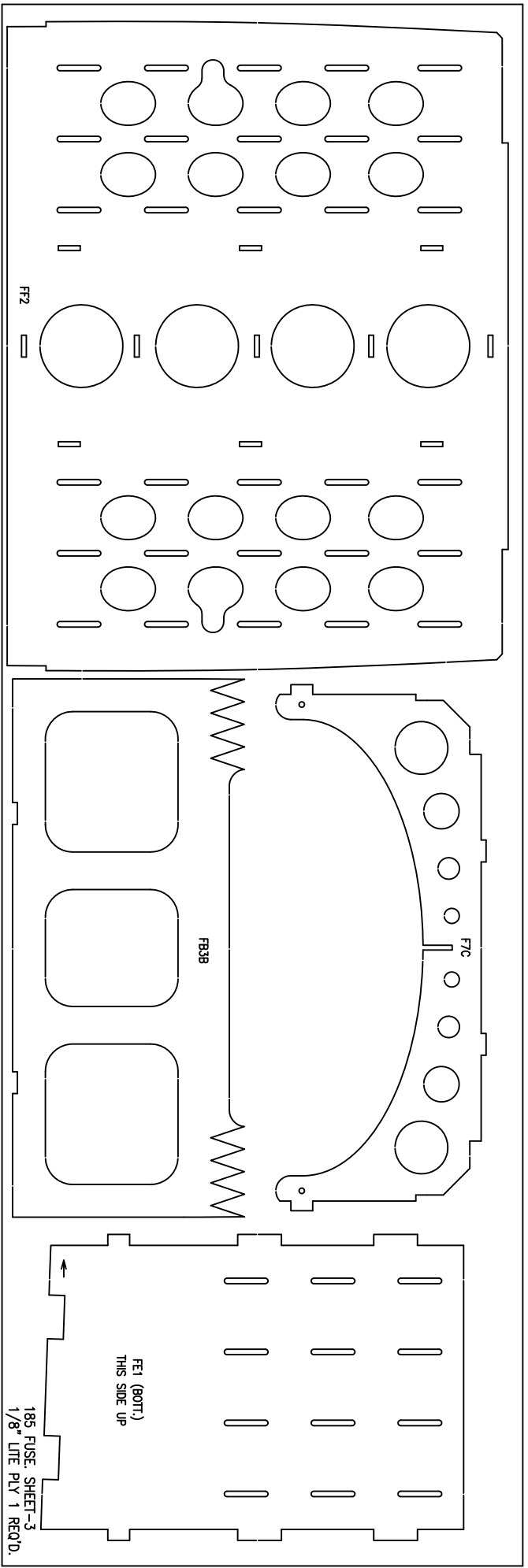

12" WIDE x 36" LONG x 1/8" THICK LITE PLY ONE (1) REQUIRED

185 FUSES PARTS SHEET-2

185 FUSE SHEET-4
1/8" LITE PLY 1 REQ'D.

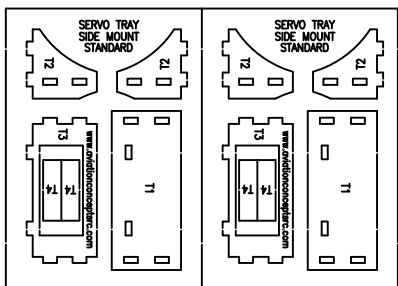
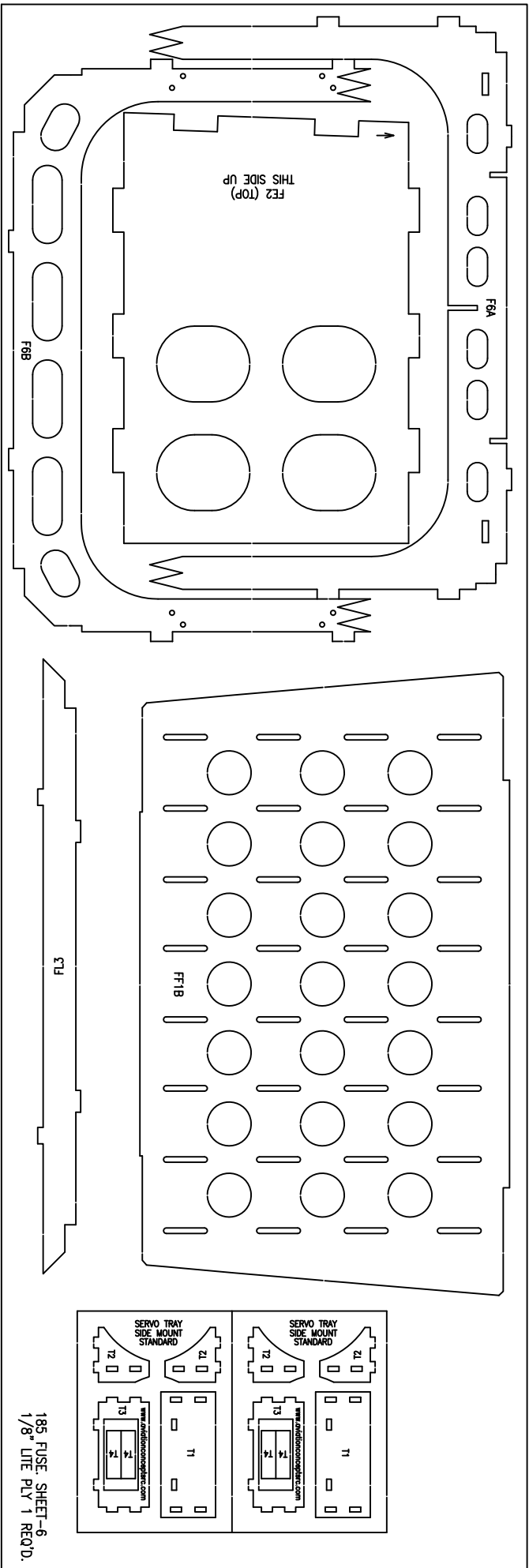
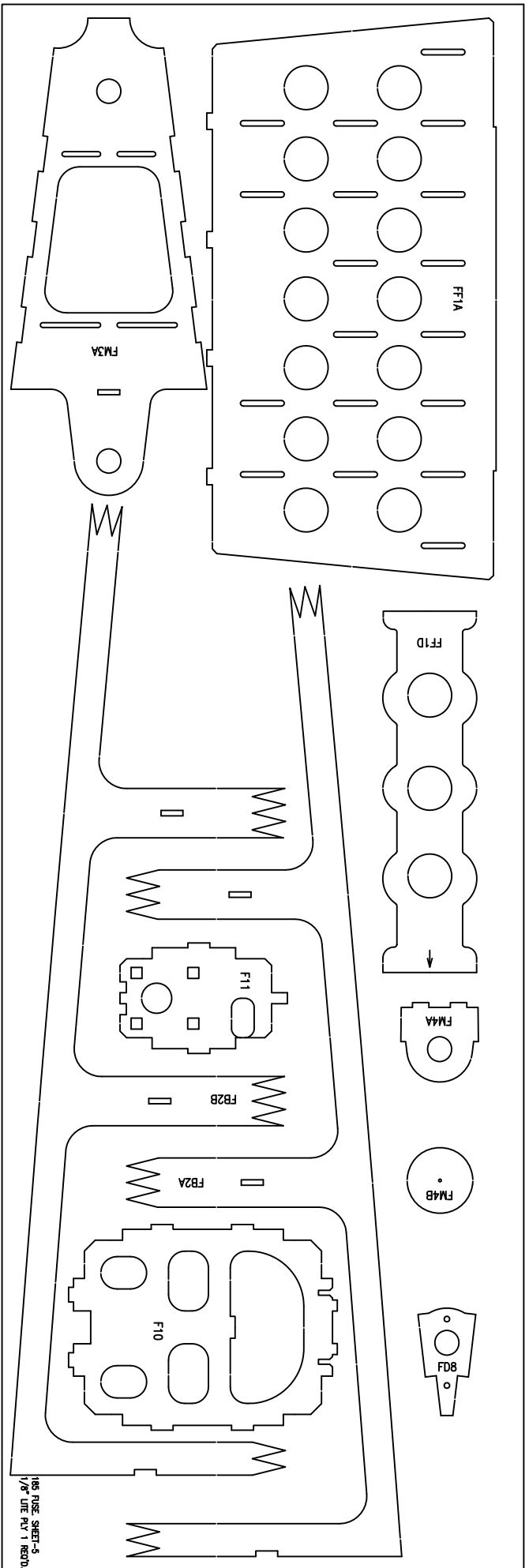

12" WIDE x 36" LONG x 1/8" THICK LITE PLY ONE (1) REQUIRED

185 FUSES PARTS SHEET-3

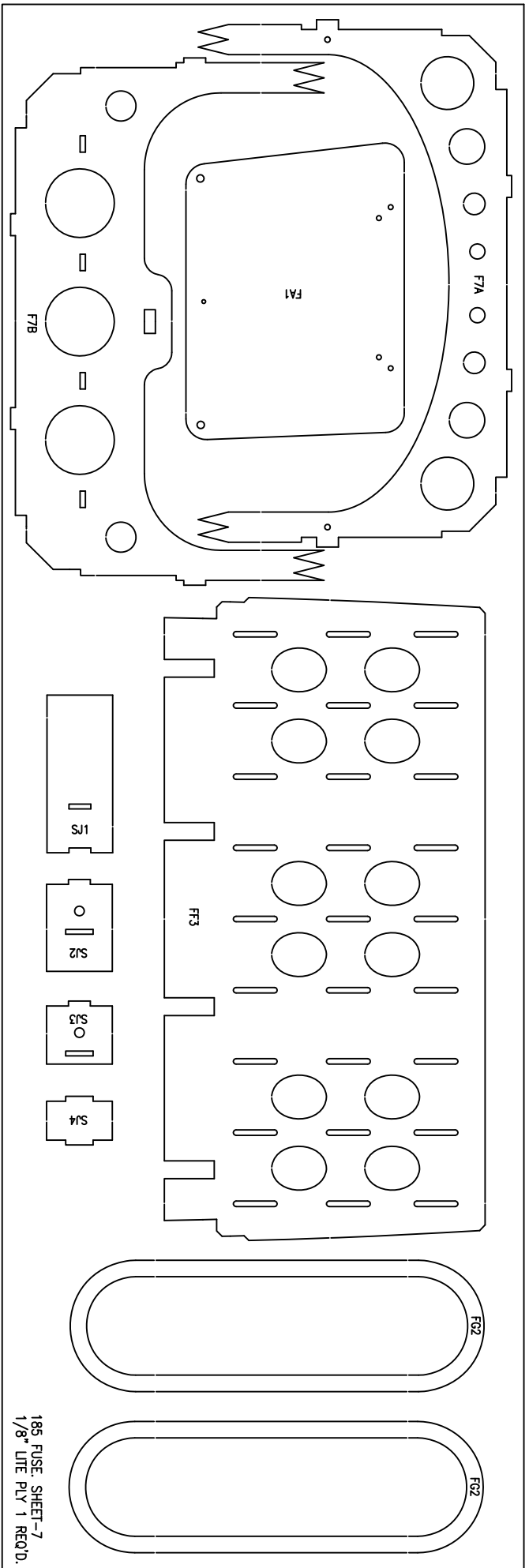

12" WIDE x 36" LONG x 1/8" THICK LITE PLY ONE (1) REQUIRED

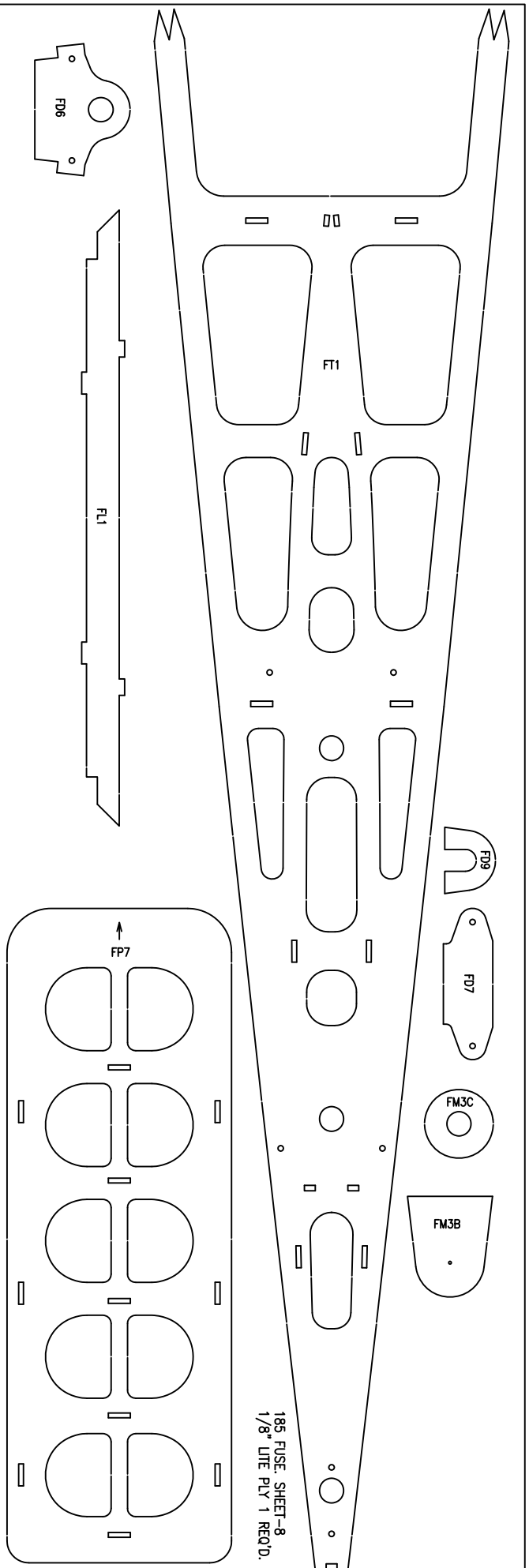

12" WIDE x 36" LONG x 1/8" THICK LITE PLY ONE (1) REQUIRED

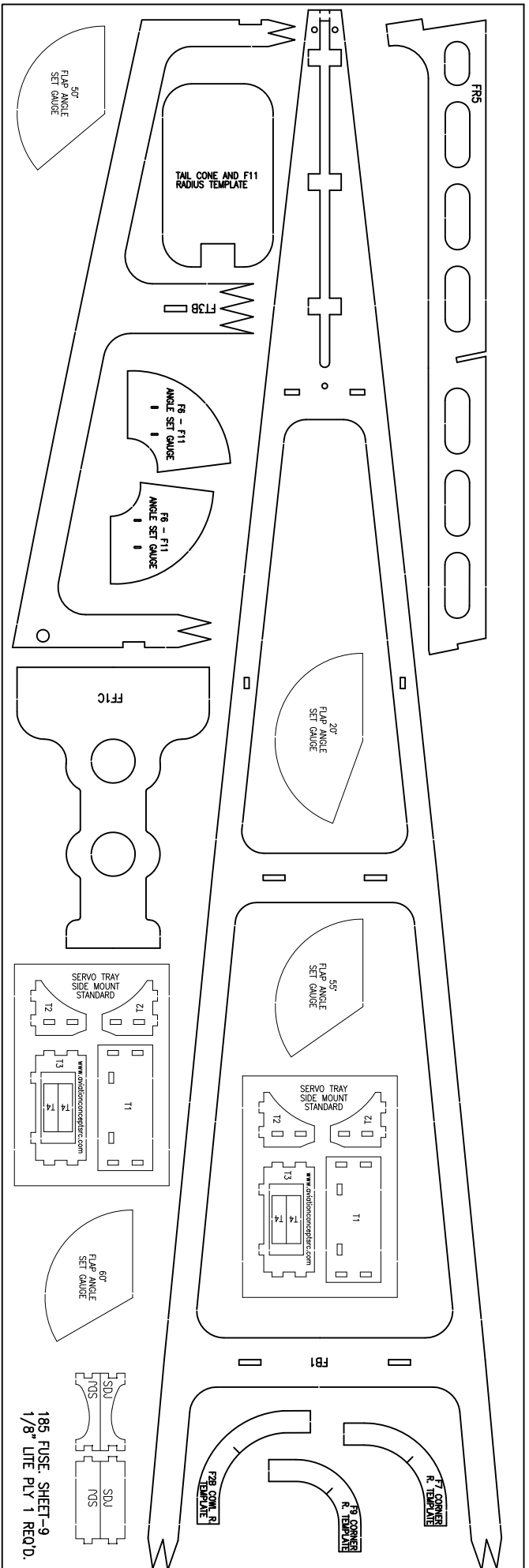

12" WIDE x 36" LONG x 1/8" THICK LITE PLY ONE (1) REQUIRED

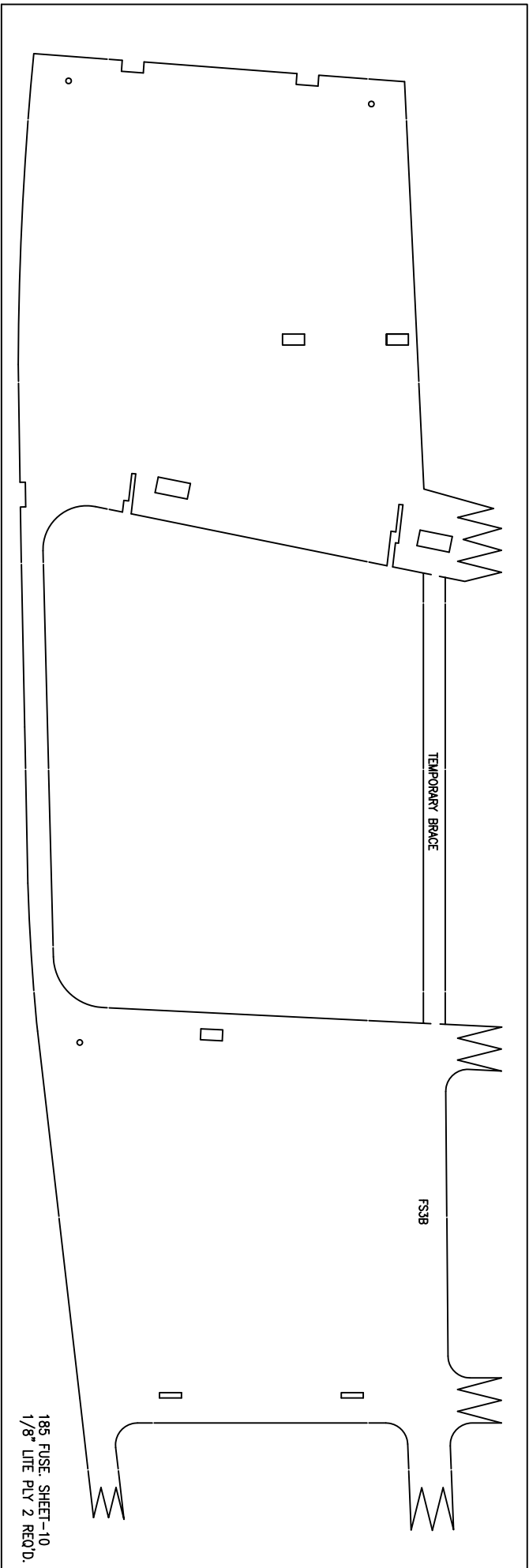

12" WIDE x 36" LONG x 1/8" THICK LITE PLY TWO (2) REQUIRED

185 FUSE PARTS SHEET-5

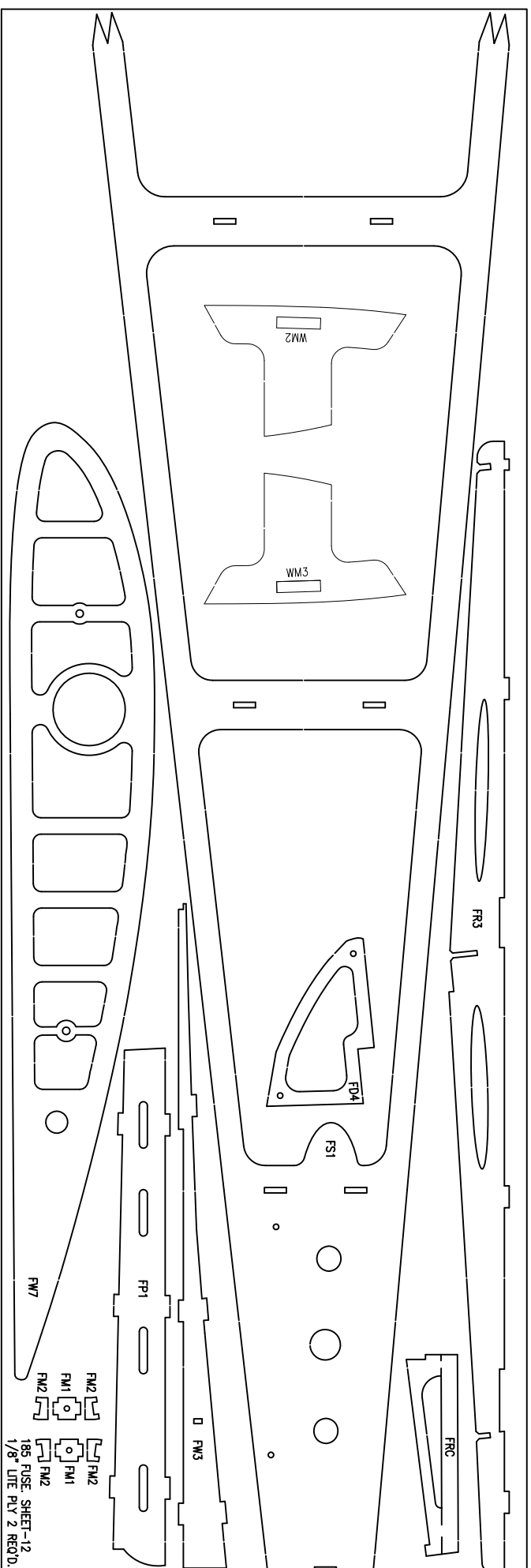
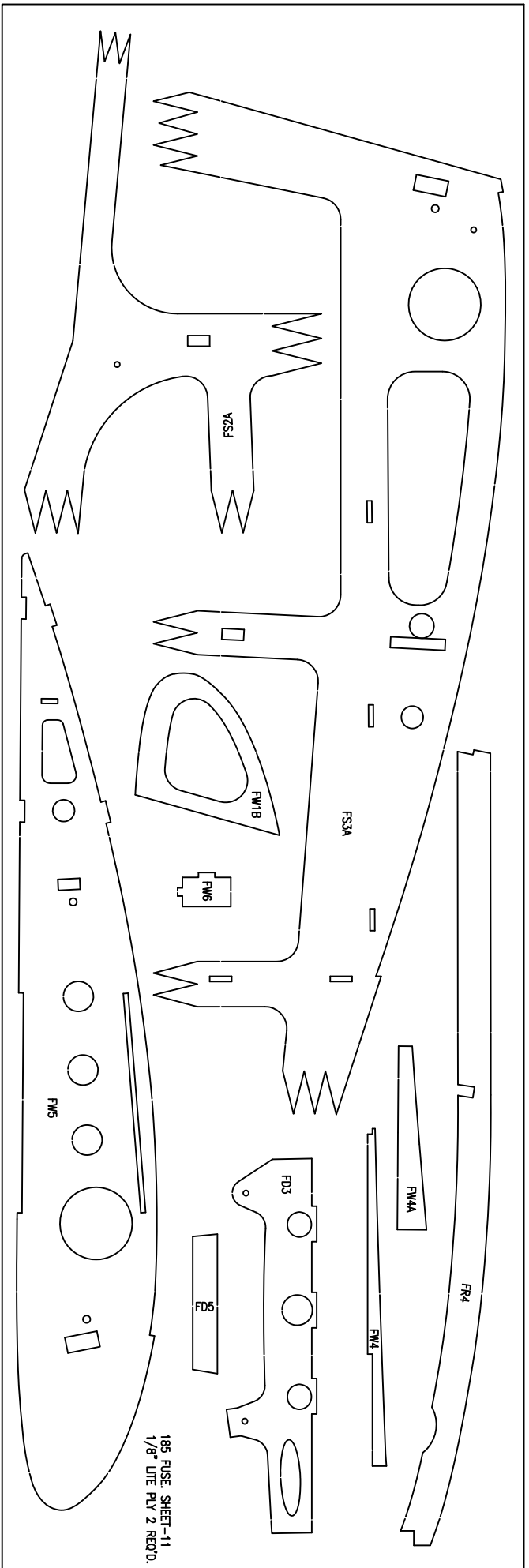

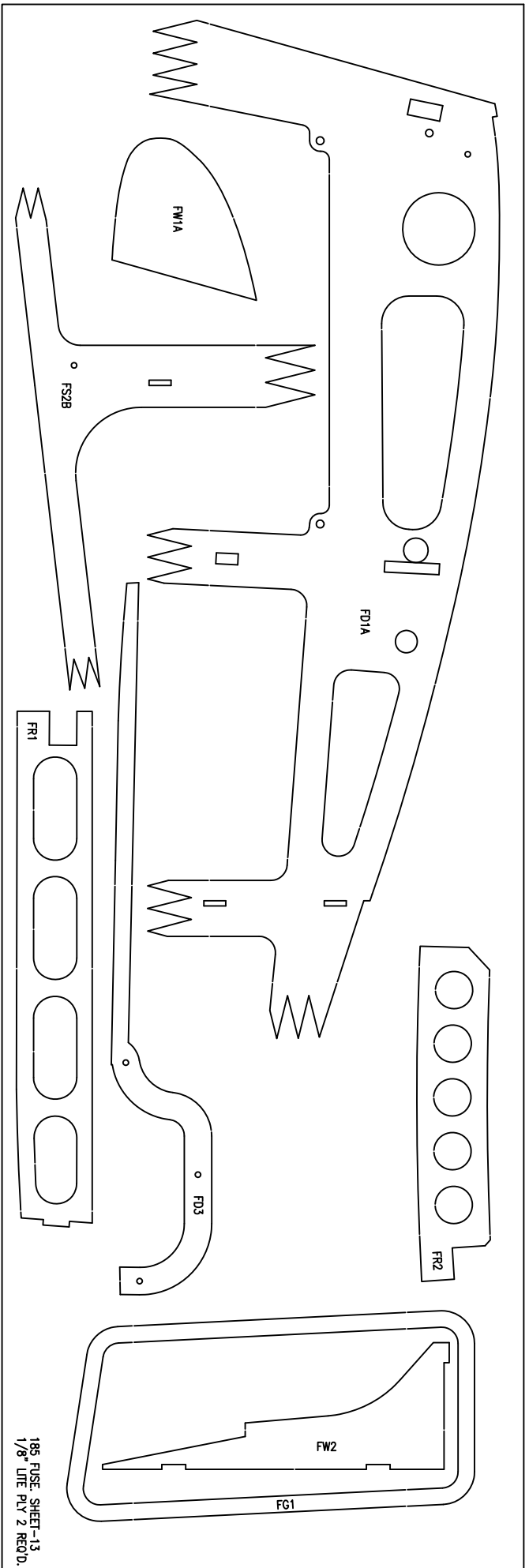

12" WIDE x 36" LONG x 1/8" THICK LITE PLY TWO (2) REQUIRED

185 FUSE. SHEET-13
1/8" LITE PLY 2 REQ'D.

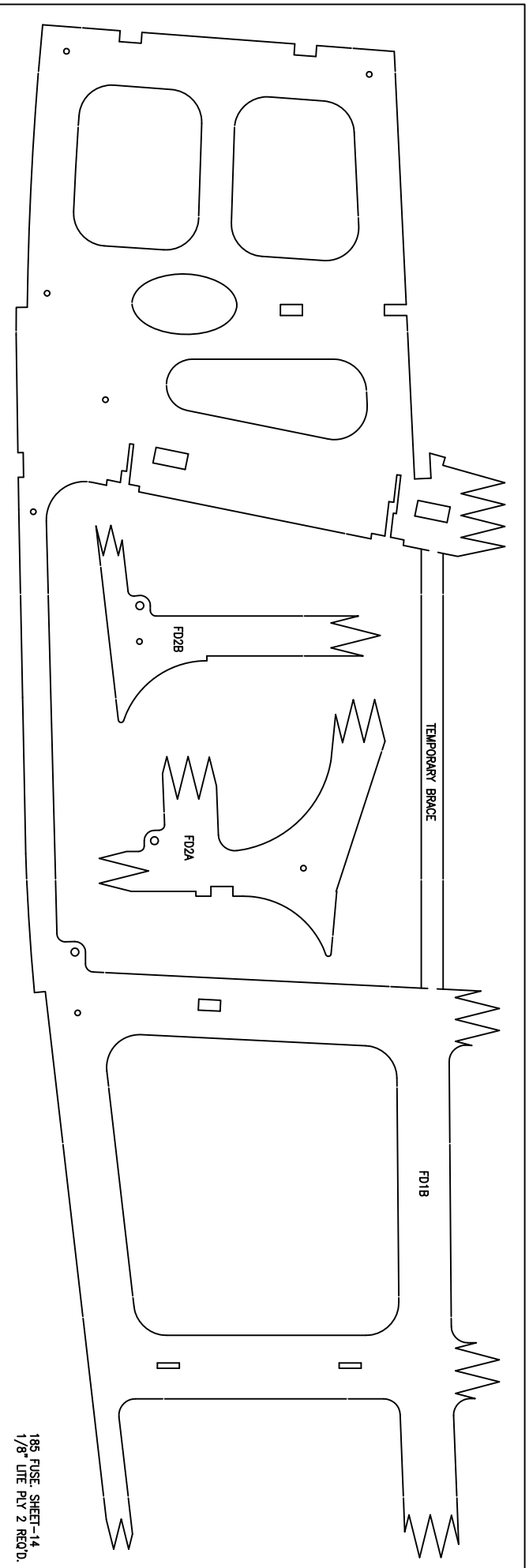

12" WIDE x 36" LONG x 1/8" THICK LITE PLY TWO (2) REQUIRED

185 FUSE. SHEET-14
1/8" LITE PLY 2 REQ'D.

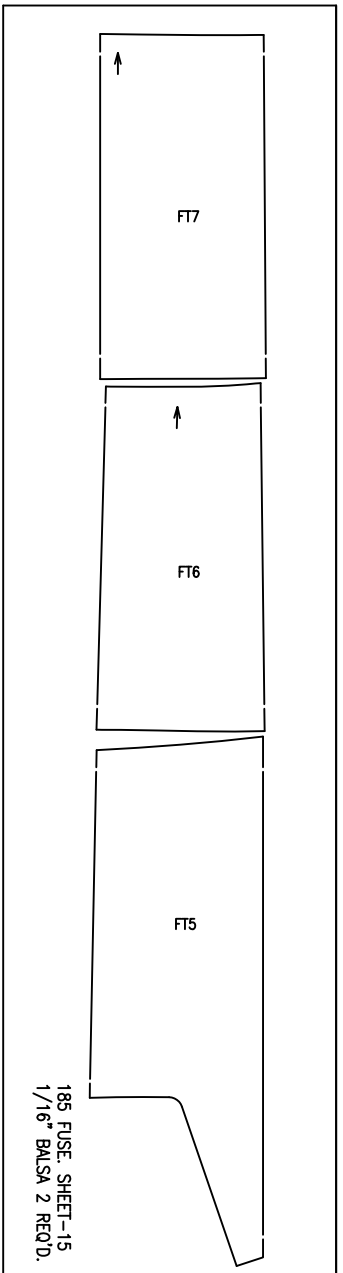

6" WIDE x 25" LONG x 1/16" THICK BALSA TWO (2) REQUIRED

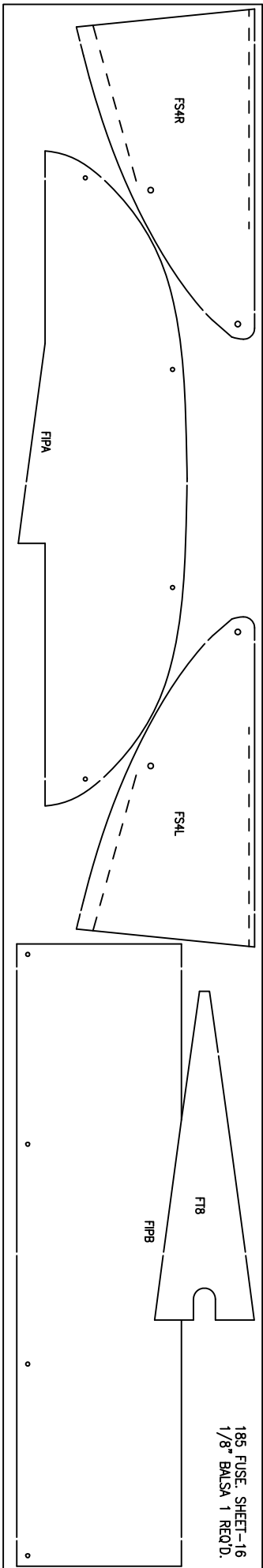

6" WIDE x 36" LONG x 1/8" THICK BALSA ONE (1) REQUIRED

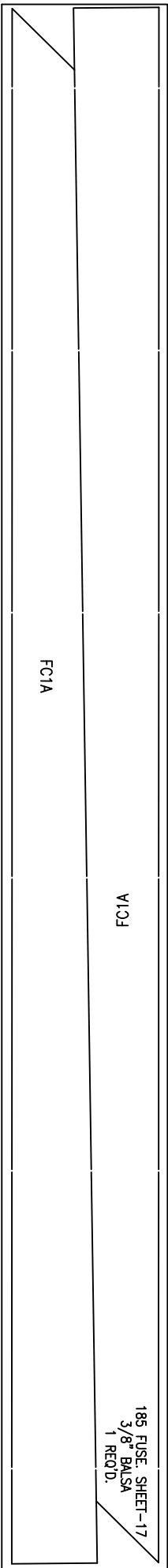

4" WIDE x 36" LONG x 3/8" THICK BALSA ONE (1) REQUIRED

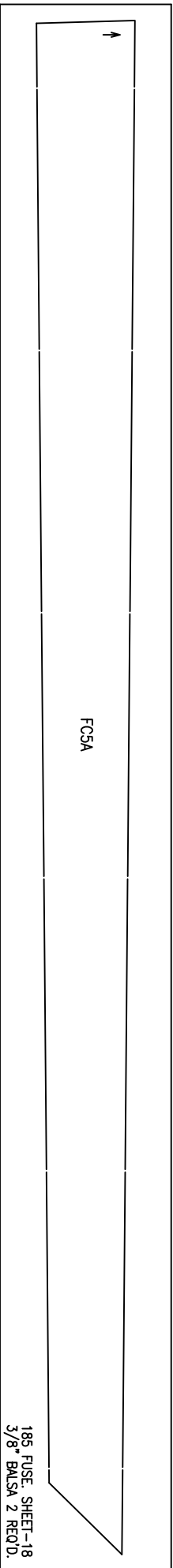

4" WIDE x 36" LONG x 3/8" THICK BALSA TWO (2) REQUIRED

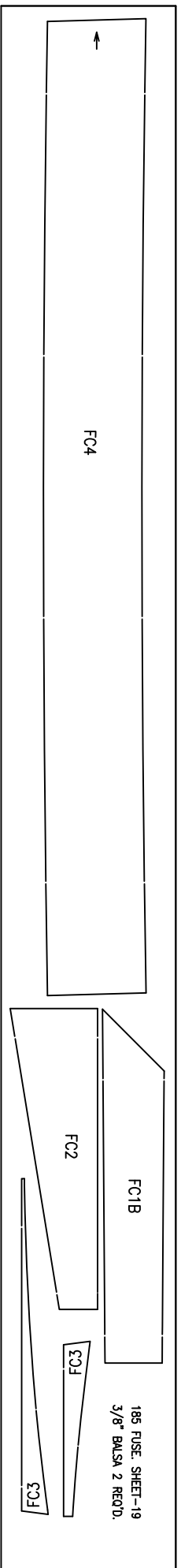

4" WIDE x 36" LONG x 3/8" THICK BALSAM TWO (2) REQUIRED

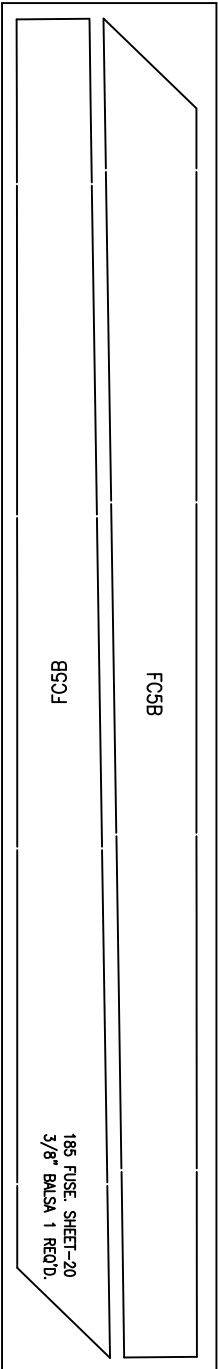

4" WIDE x 36" LONG x 3/8" THICK BALSAM ONE (1) REQUIRED

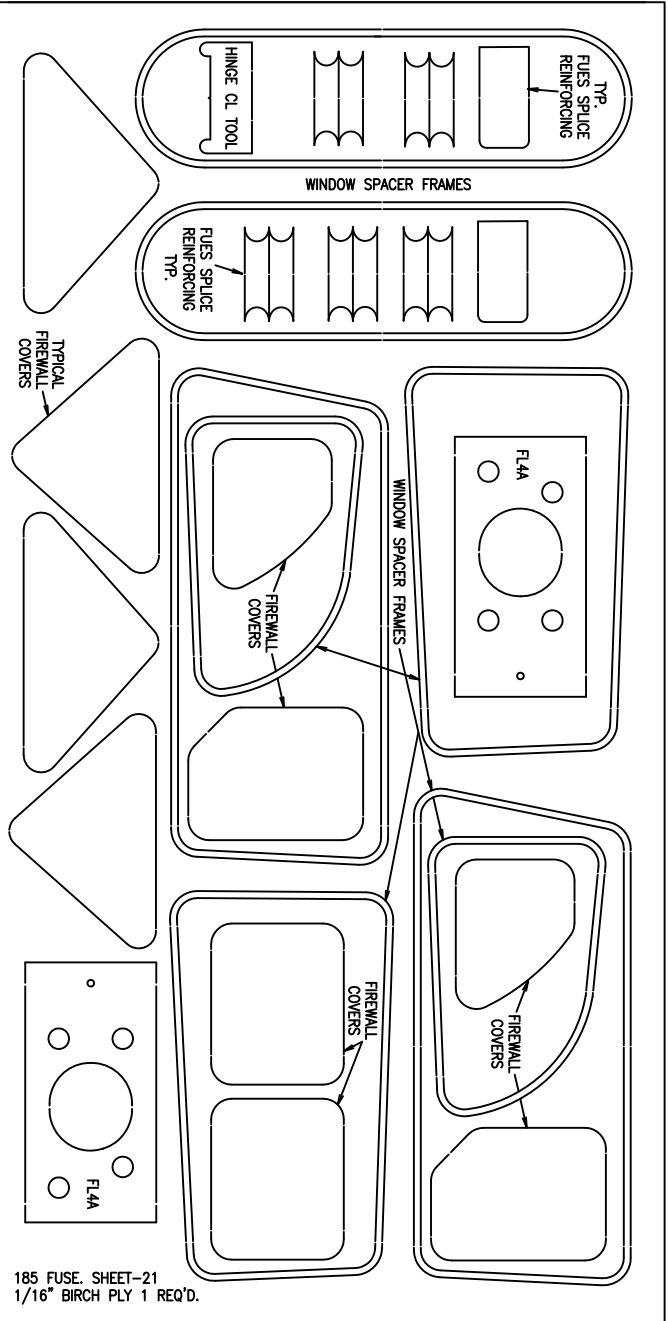

12" WIDE x 24" LONG x 1/16" THICK BIRCH PLY ONE (1) REQUIRED

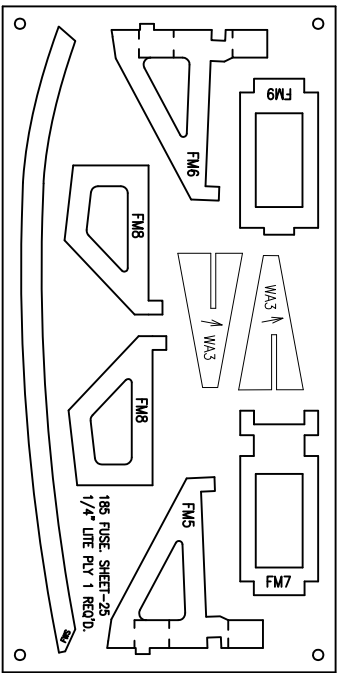
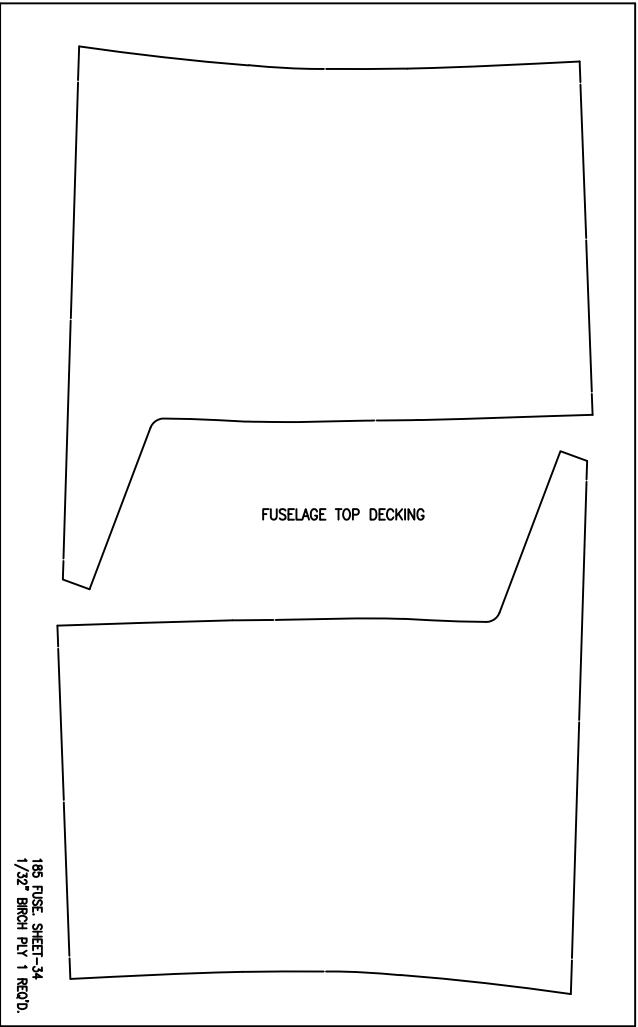
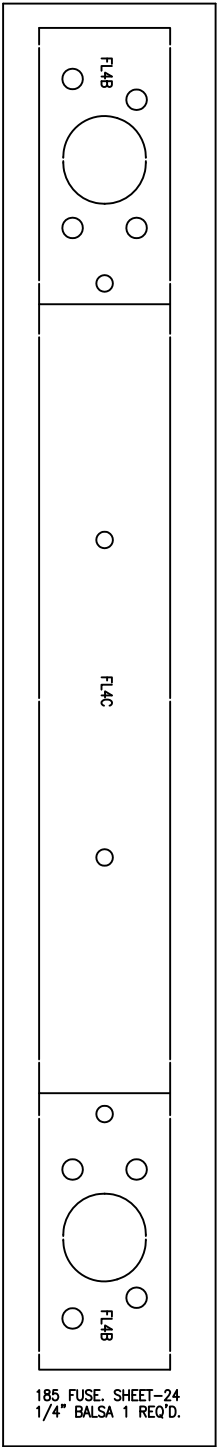
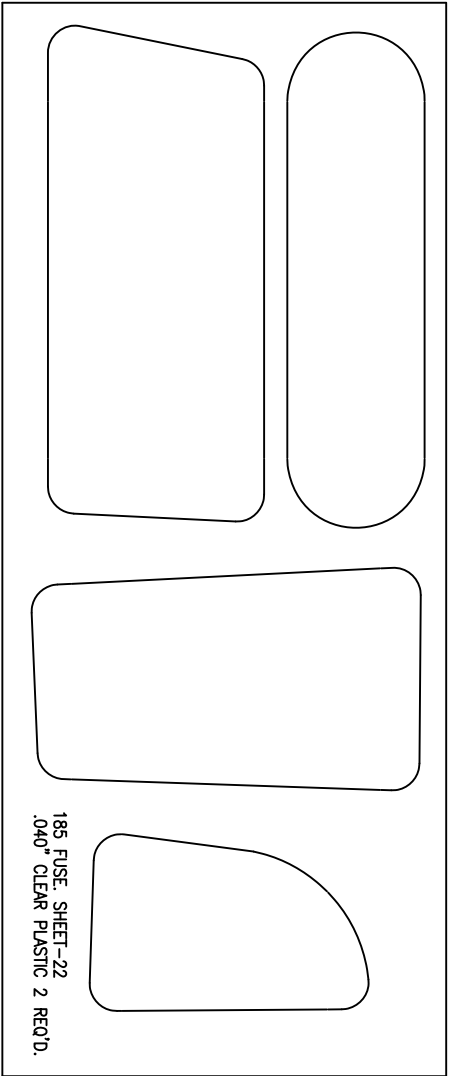

12" WIDE x 18" LONG x 1/32" THICK BIRCH PLY ONE (1) REQUIRED

185 FUSES PARTS SHEET-10

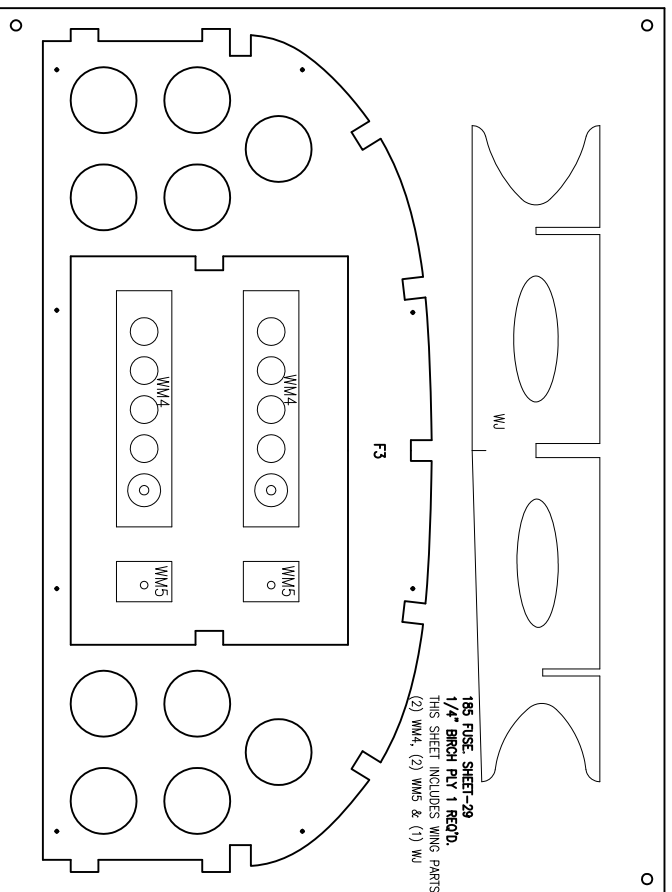
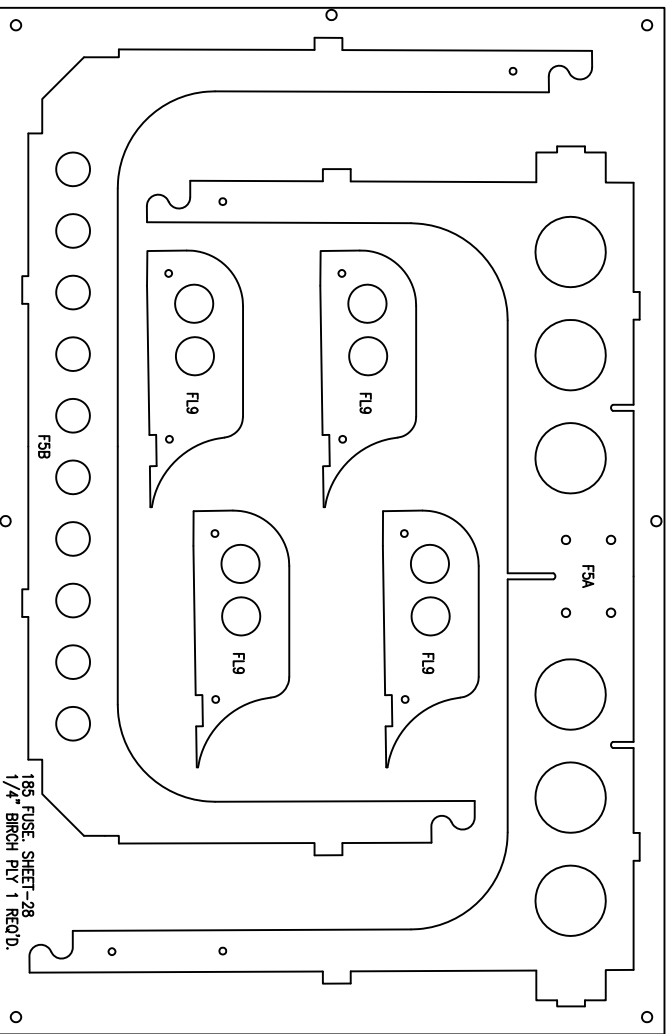
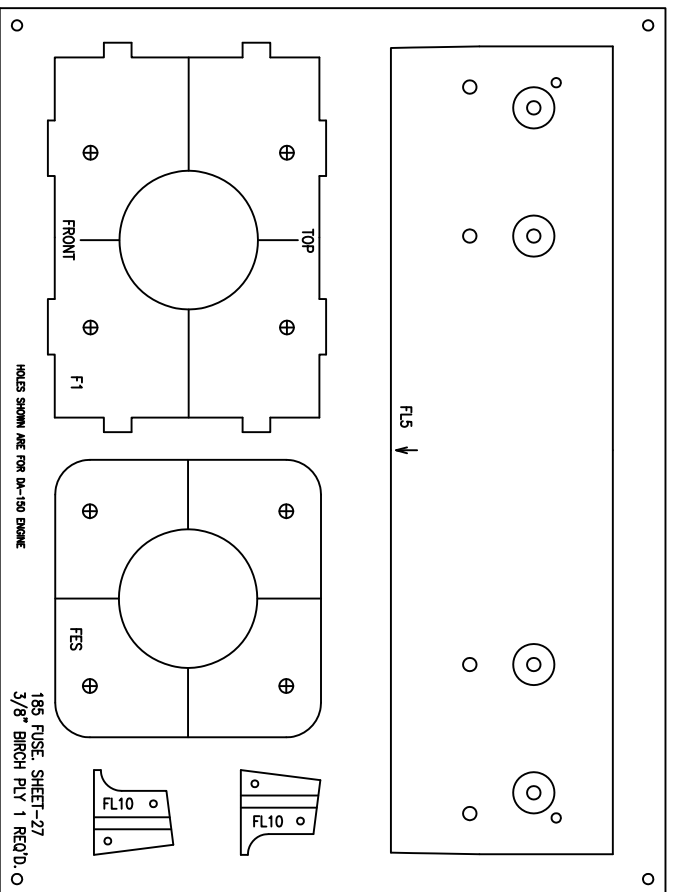
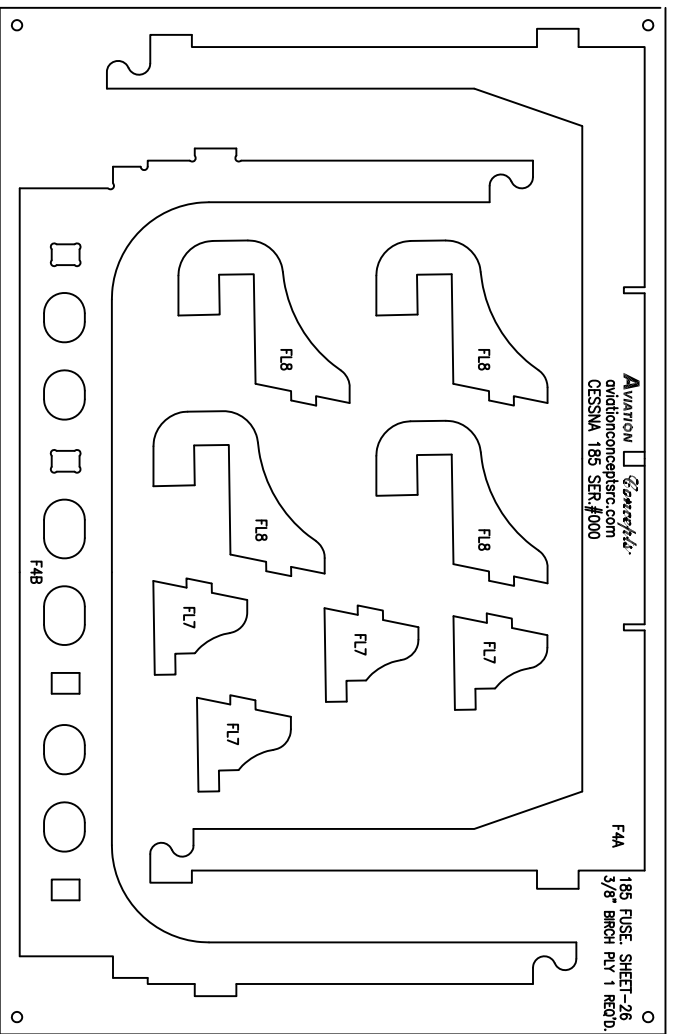

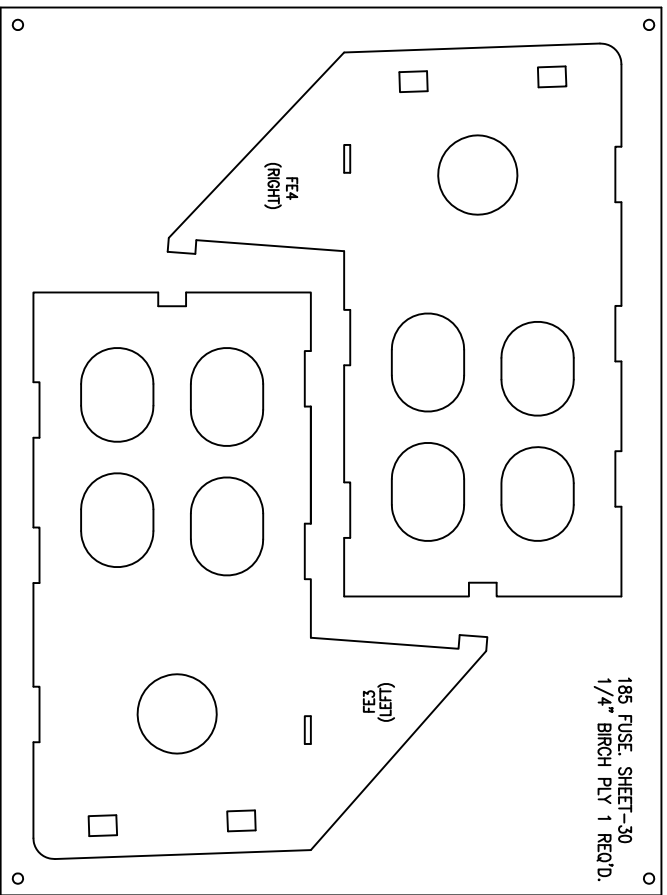

12" WIDE x 16" LONG x 1/4" THICK BIRCH PLY ONE (1) REQUIRED

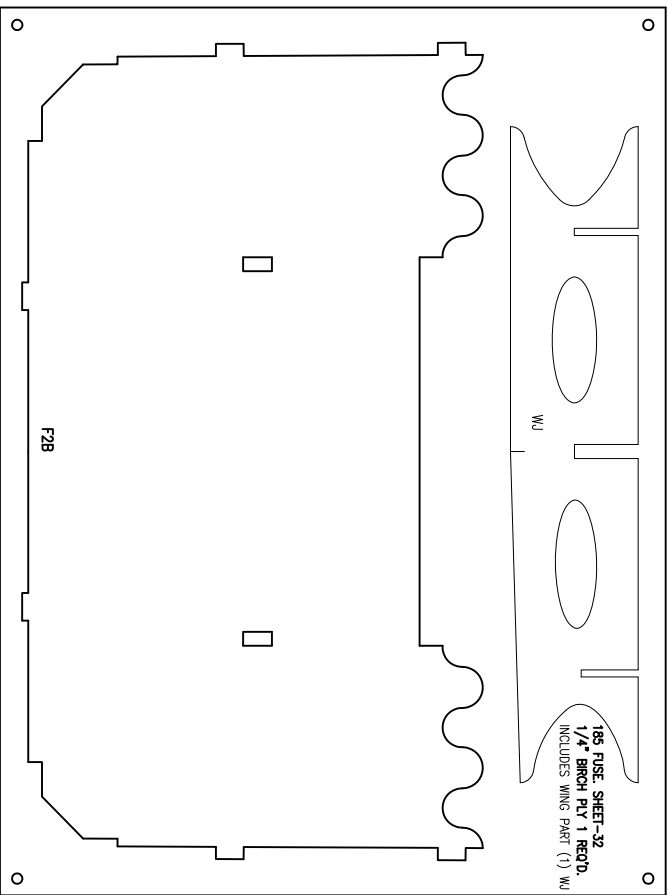

12" WIDE x 16" LONG x 1/4" THICK BIRCH PLY ONE (1) REQUIRED

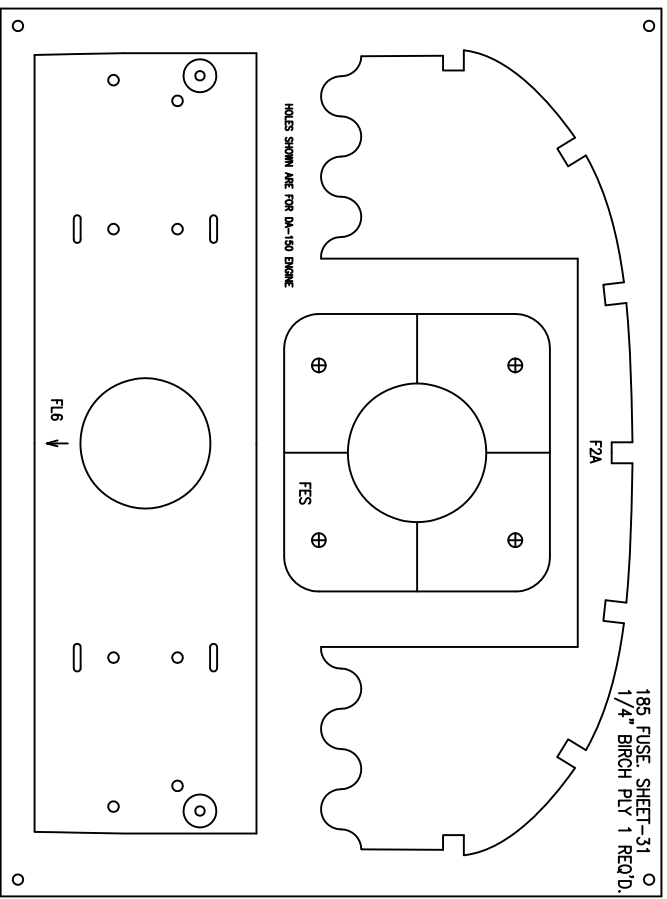

12" WIDE x 16" LONG x 1/4" THICK BIRCH PLY ONE (1) REQUIRED

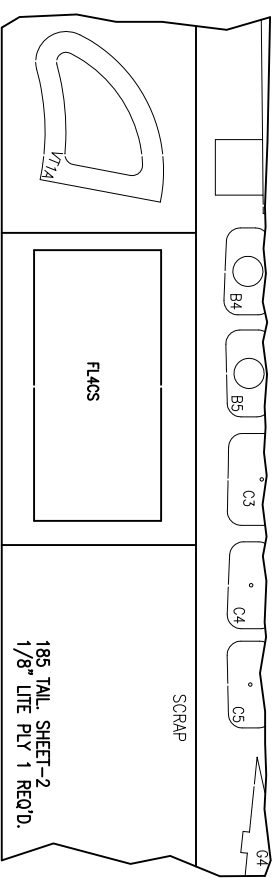

12" WIDE x 36" LONG x 1/8" THICK LITE PLY ONE (1) REQUIRED

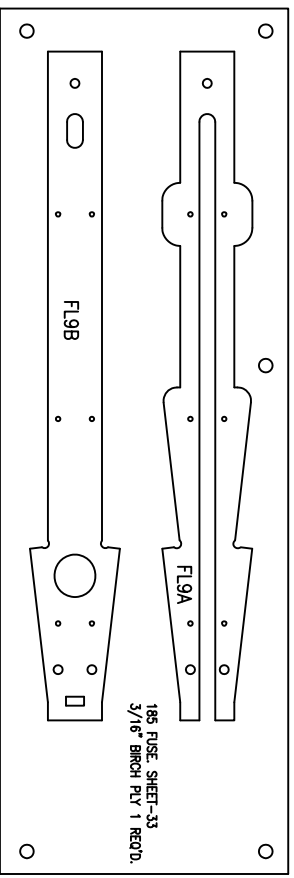

4" WIDE x 12" LONG x 3/16" THICK BIRCH PLY ONE (1) REQUIRED

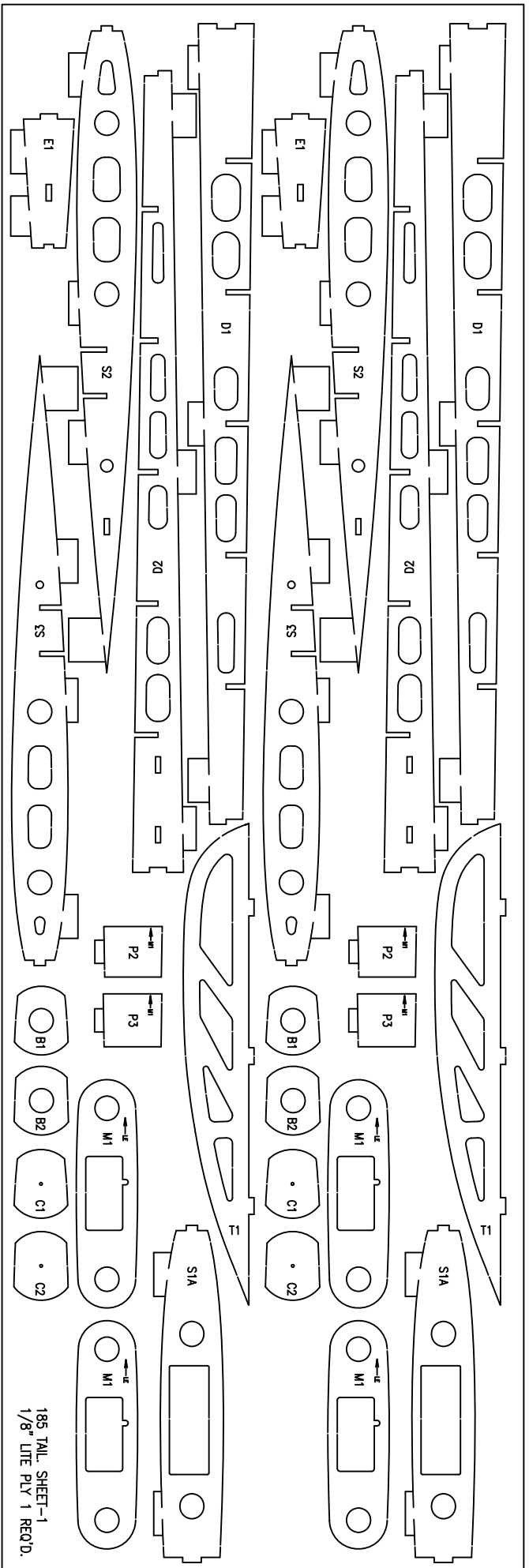

12" WIDE x 36" LONG x 1/8" THICK LITE PLY ONE (1) REQUIRED

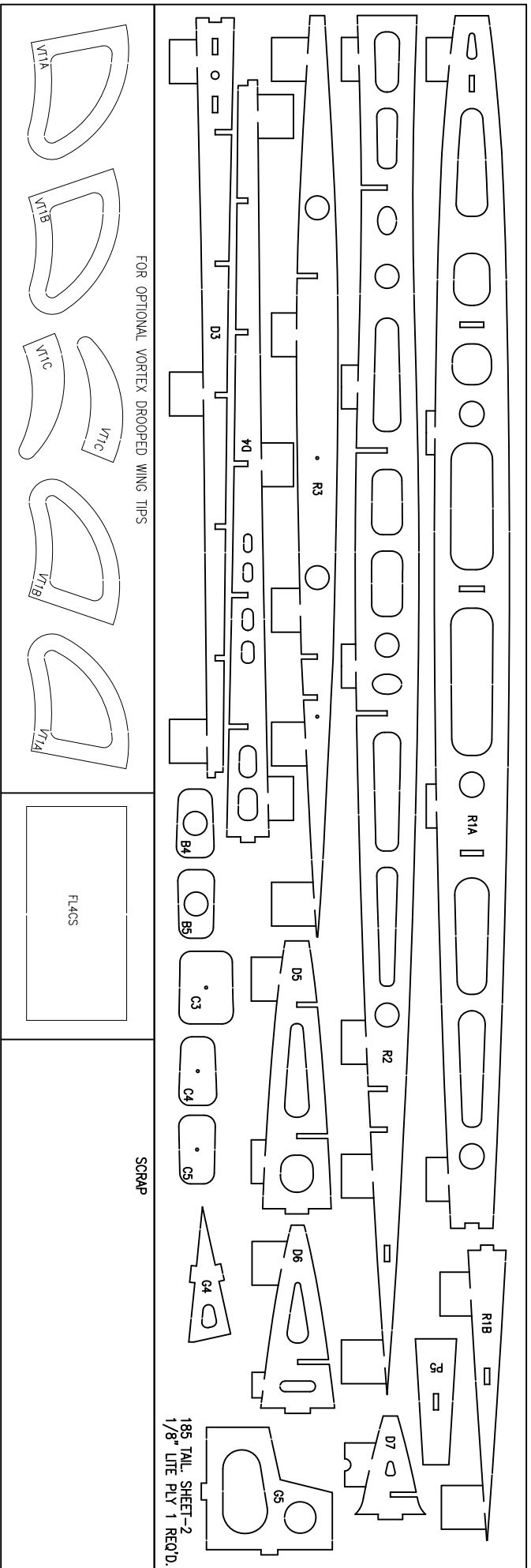

FOR OPTIONAL VORTEX DROOPED WING TIPS

SCRAP

FL4CS

12" WIDE x 36" LONG x 1/8" THICK LITE PLY ONE (1) REQUIRED

185 TAIL PARTS SHEET-13

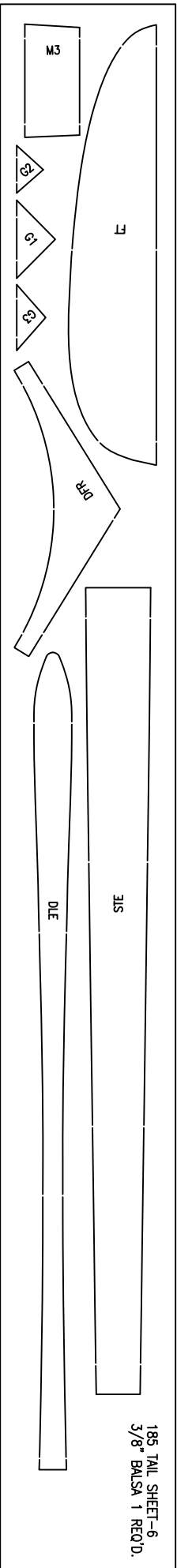
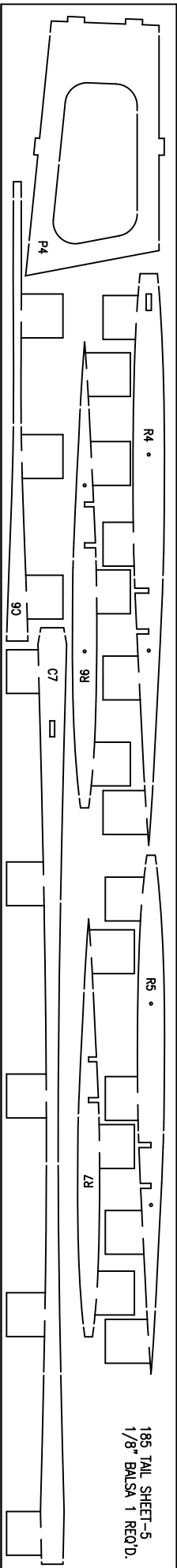
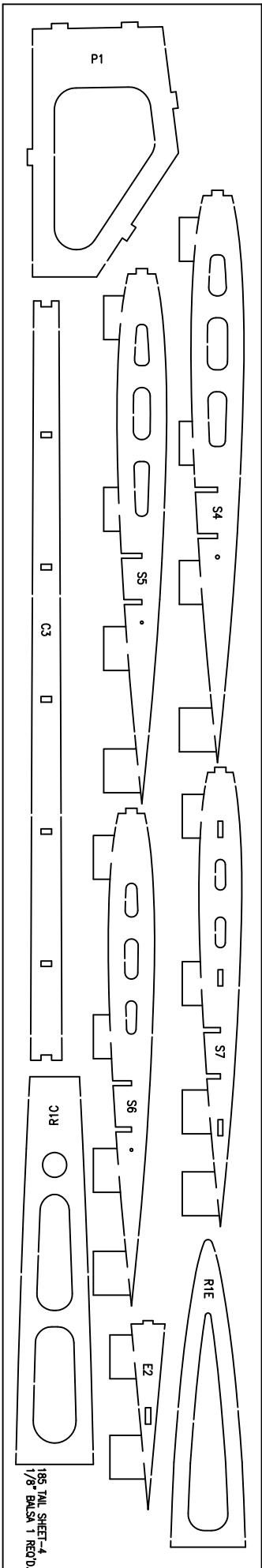
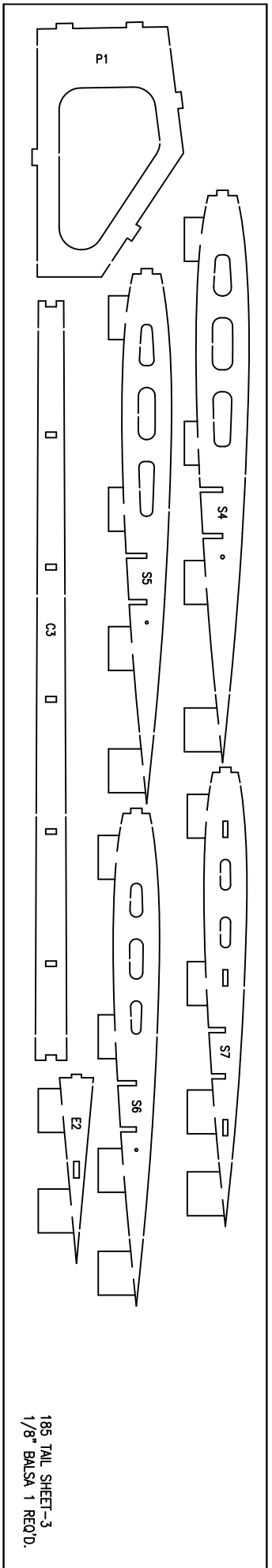

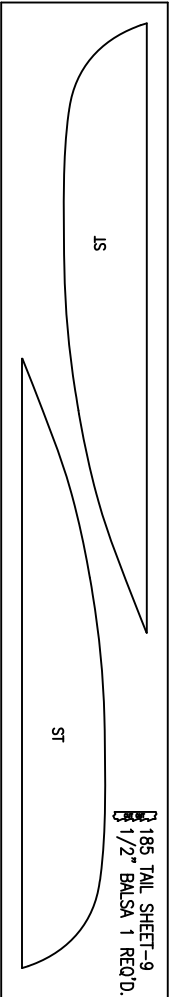
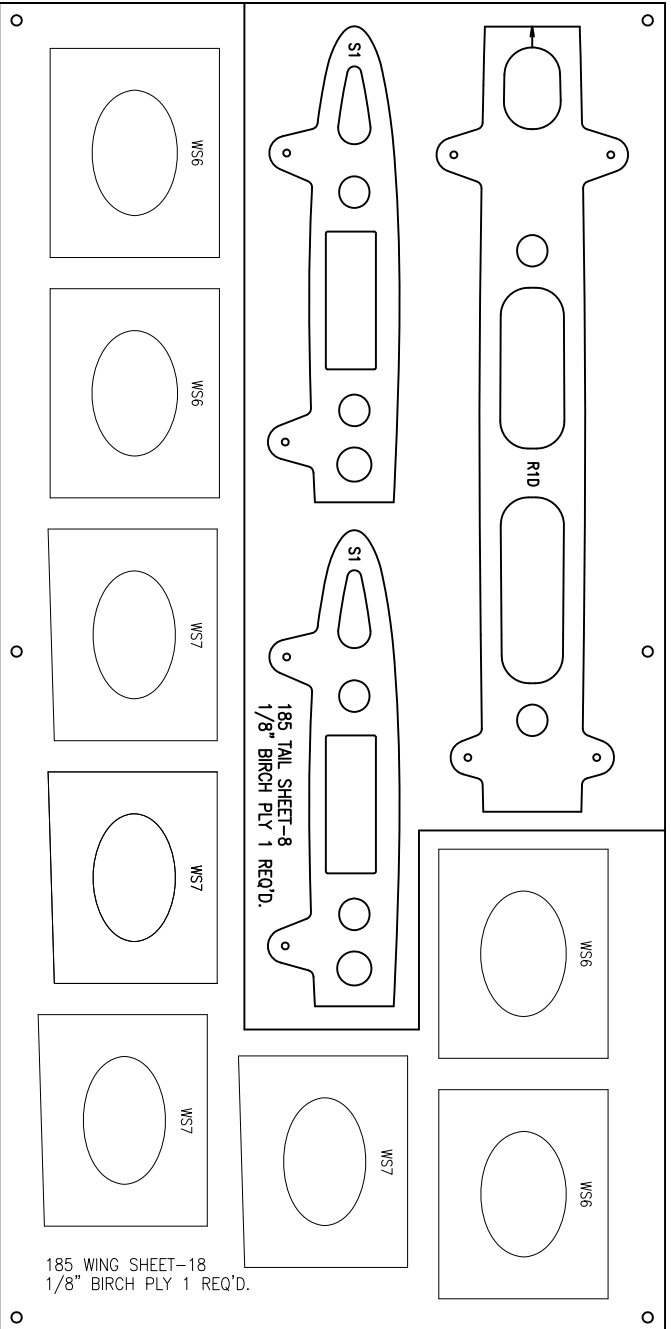
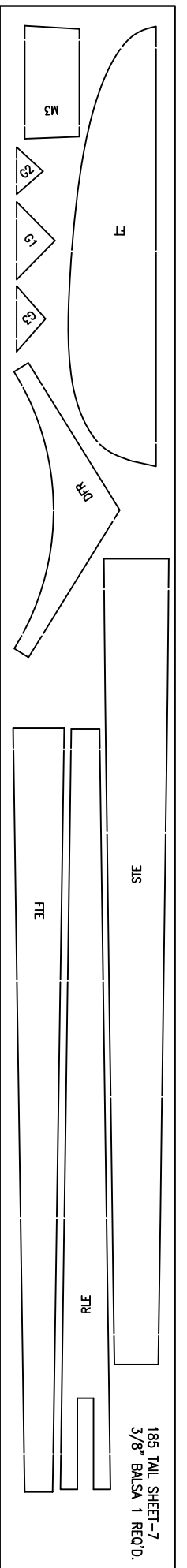

3" WIDE x 18" LONG x 1/2" THICK BALSAs ONE (1) REQUIRED

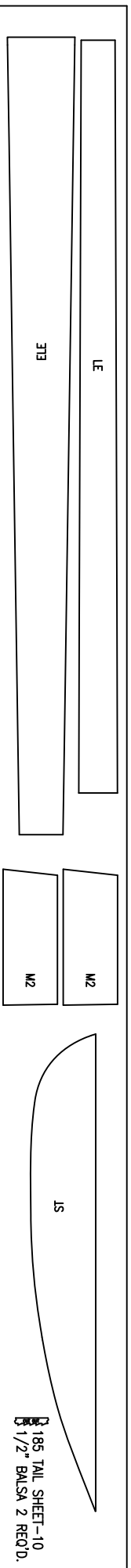

3" WIDE x 36" LONG x 1/2" THICK BALSAs TWO (2) REQUIRED

185 TAIL PARTS SHEET-15

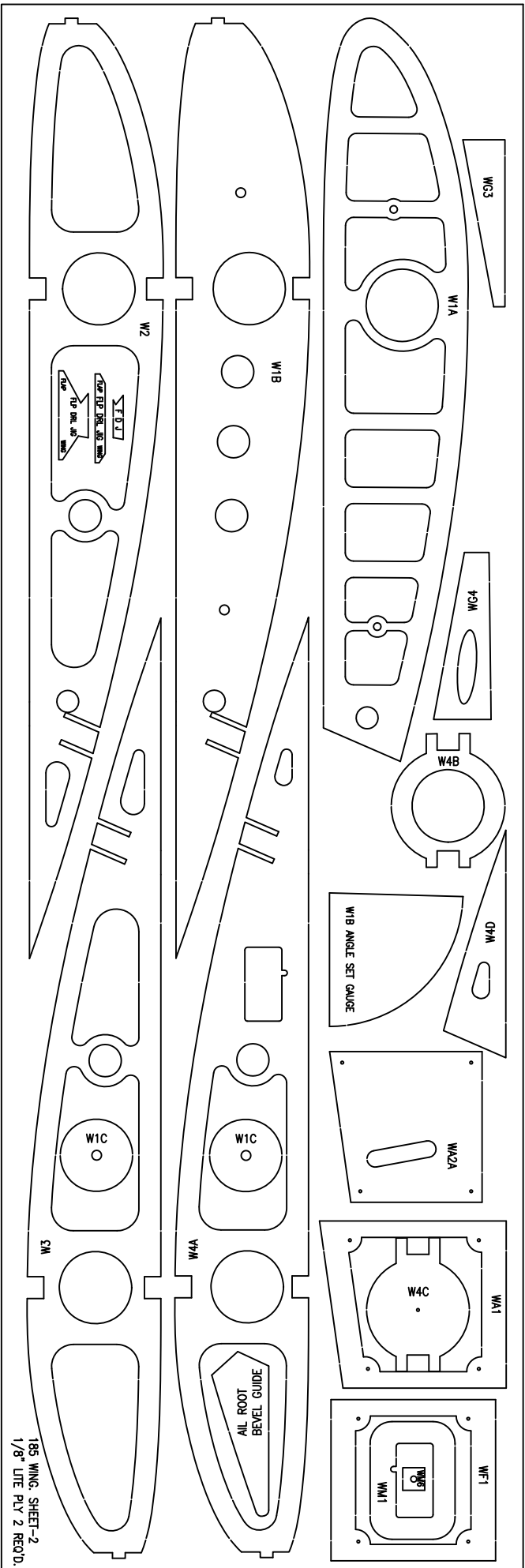
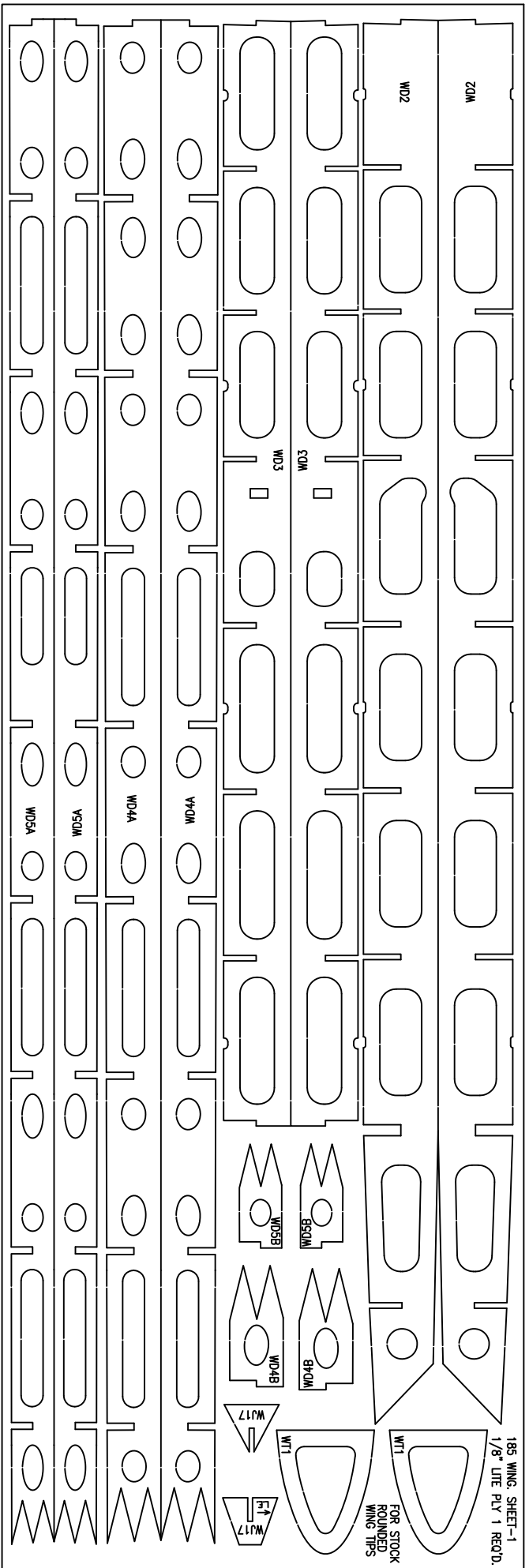

12" WIDE x 36" LONG x 1/8" THICK LITE PLY TWO (2) REQUIRED

185 WING PARTS SHEET-16

185 WING SHEET-1
1/8" LITE PLY 1 REQ'D.

FOR STOCK
ROUNDED
WING TIPS

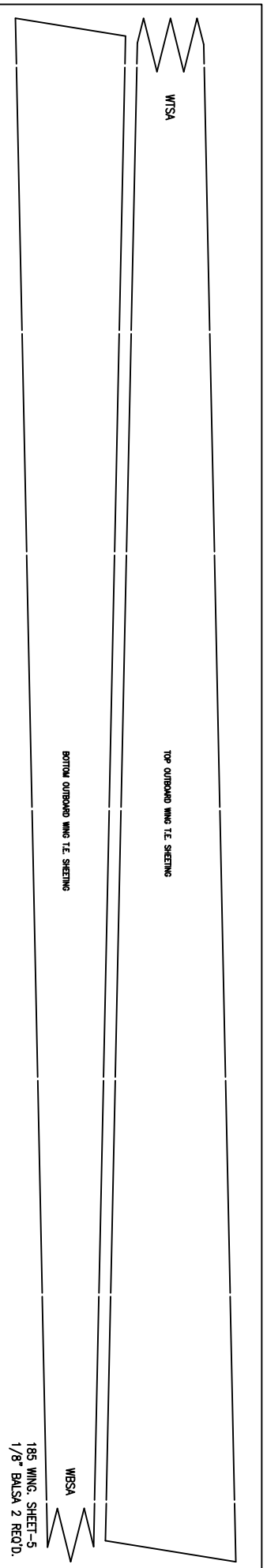
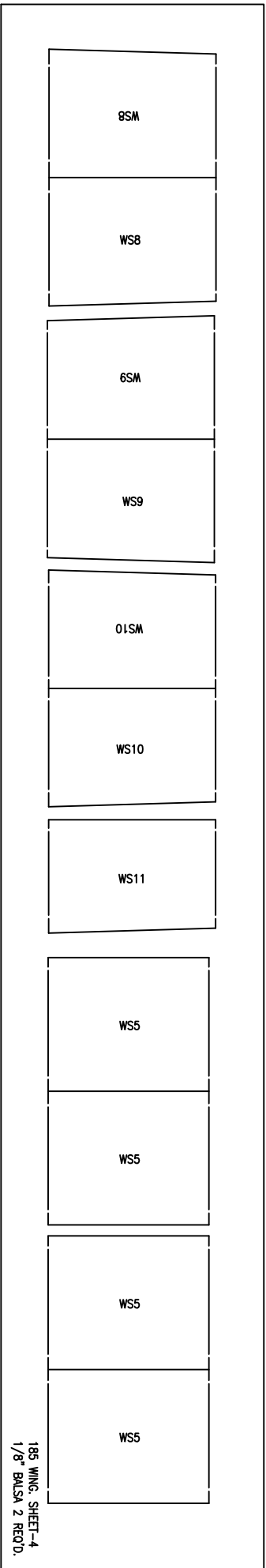
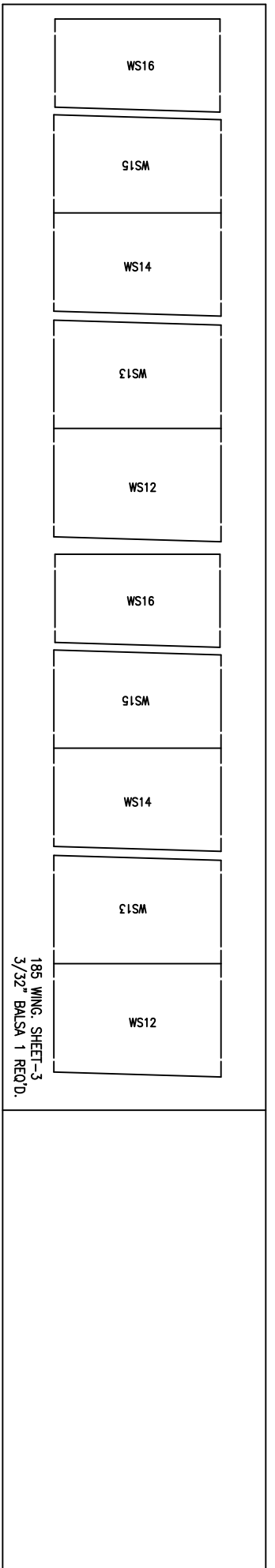

6" WIDE x 36" LONG x 1/8" THICK Balsa TWO (2) REQUIRED

185 WING PARTS SHEET-17

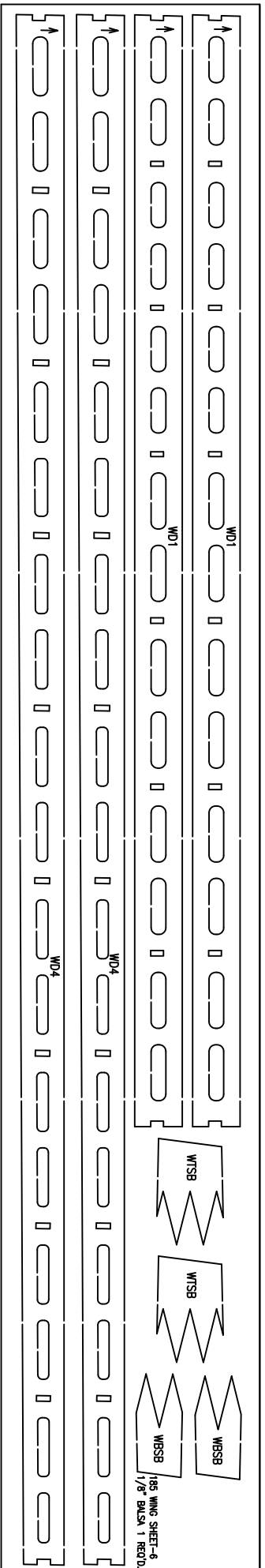

6" WIDE x 36" LONG x 1/8" THICK BALSA ONE (1) REQUIRED

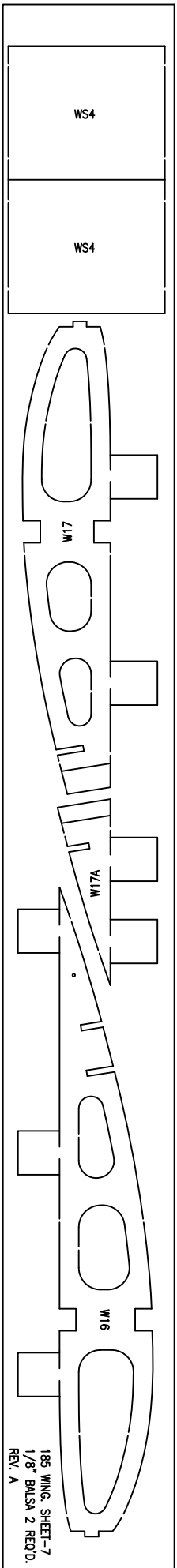

4" WIDE x 36" LONG x 1/8" THICK BALSA TWO (2) REQUIRED

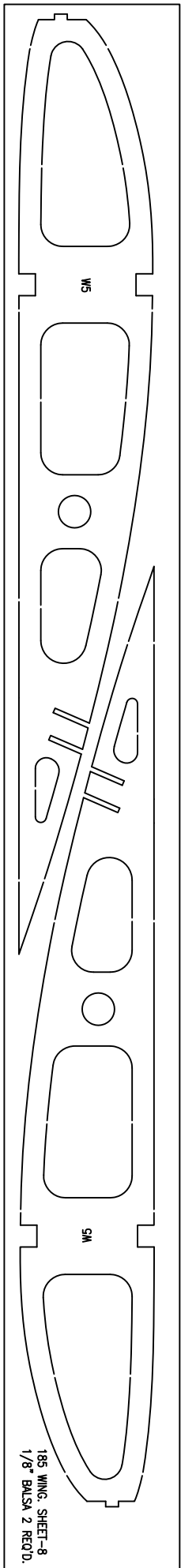

4" WIDE x 36" LONG x 1/8" THICK BALSA TWO (2) REQUIRED

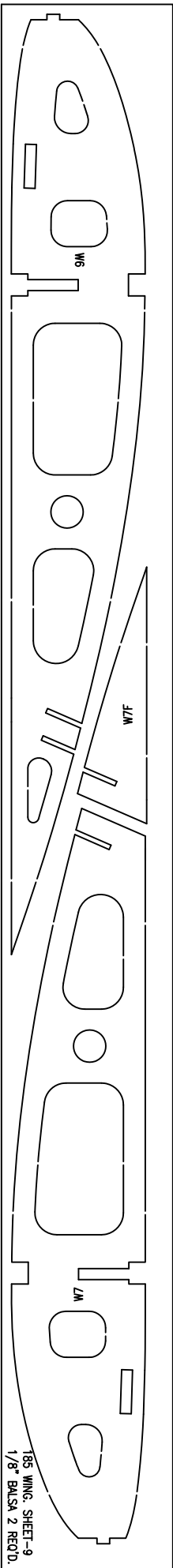

4" WIDE x 36" LONG x 1/8" THICK BALSA TWO (2) REQUIRED

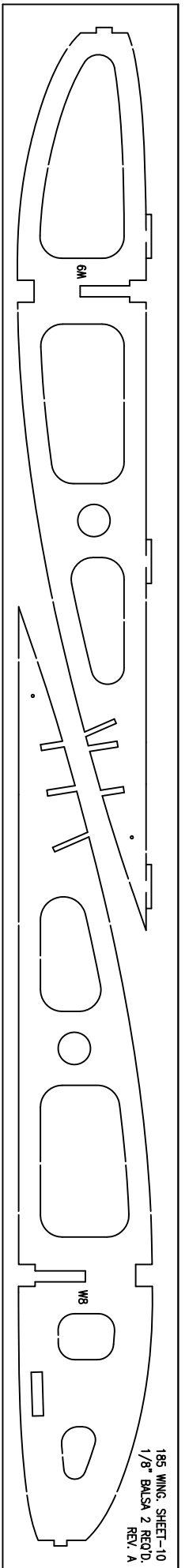

4" WIDE x 36" LONG x 1/8" THICK BALSA TWO (2) REQUIRED

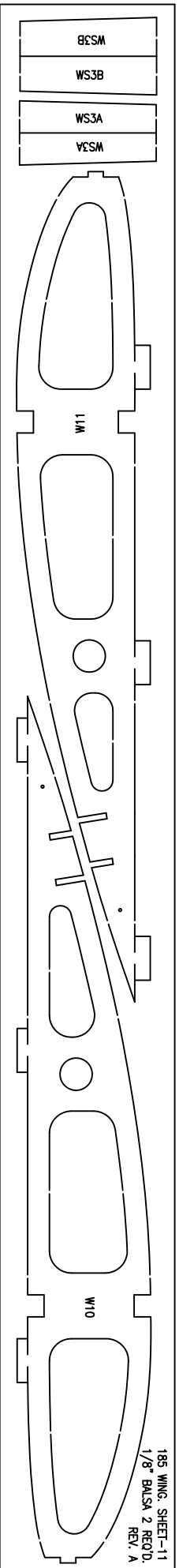

4" WIDE x 36" LONG x 1/8" THICK BALSA TWO (2) REQUIRED

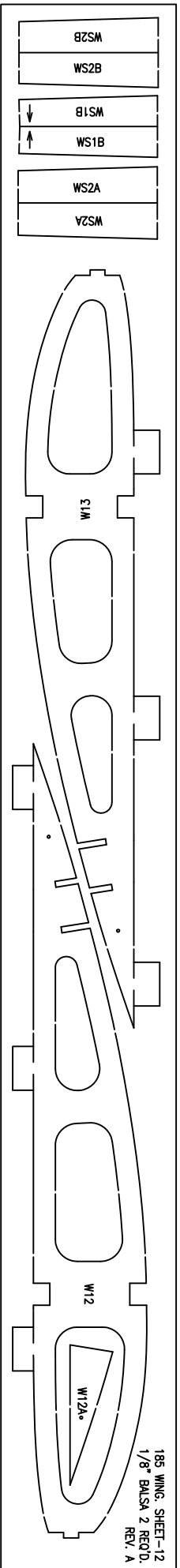

4" WIDE x 36" LONG x 1/8" THICK BALSA TWO (2) REQUIRED

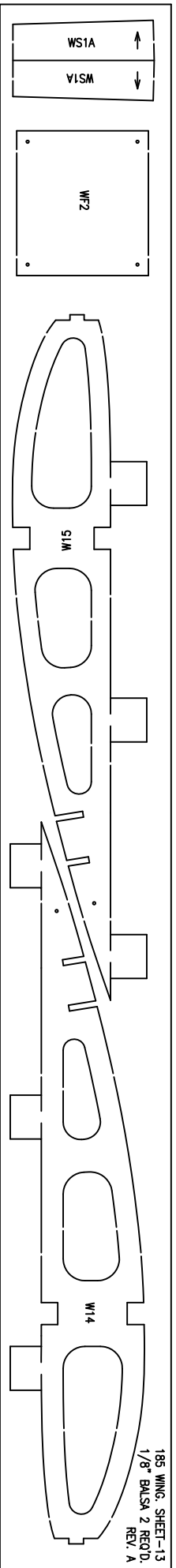

4" WIDE x 36" LONG x 1/8" THICK BALSA TWO (2) REQUIRED

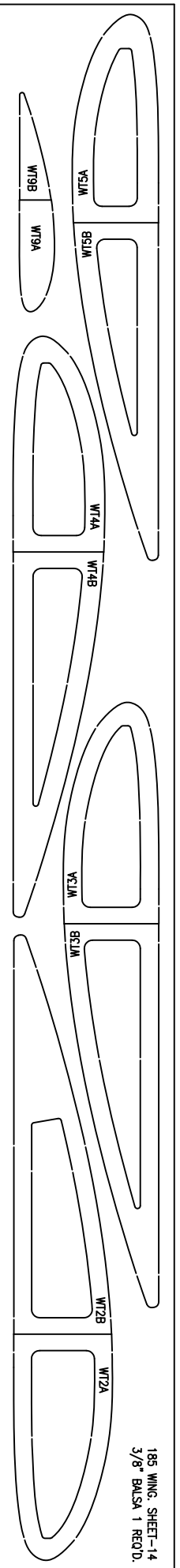

4" WIDE x 36" LONG x 3/8" THICK BALSA ONE (1) REQUIRED
FOR STOCK ROUNDED WING TIPS IF ORDERED

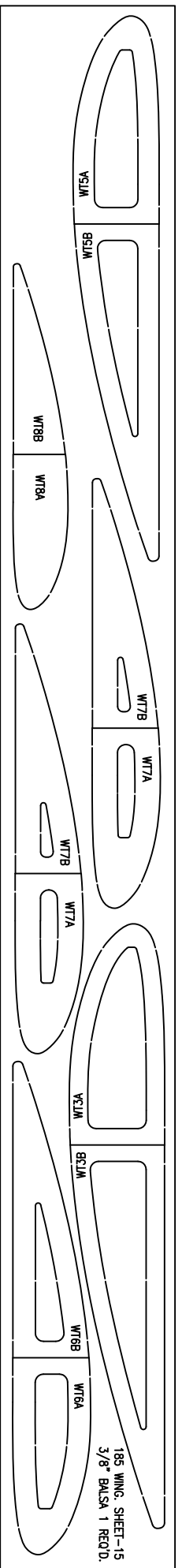

4" WIDE x 36" LONG x 3/8" THICK Balsa ONE (1) REQUIRED
FOR STOCK ROUNDED WING TIPS IF ORDERED

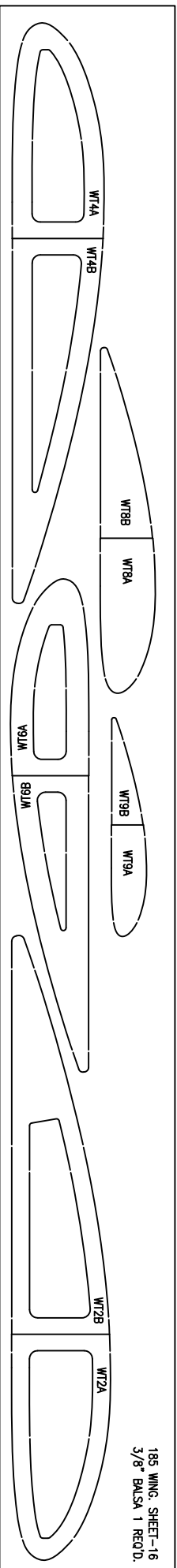

4" WIDE x 36" LONG x 3/8" THICK Balsa ONE (1) REQUIRED
FOR STOCK ROUNDED WING TIPS IF ORDERED

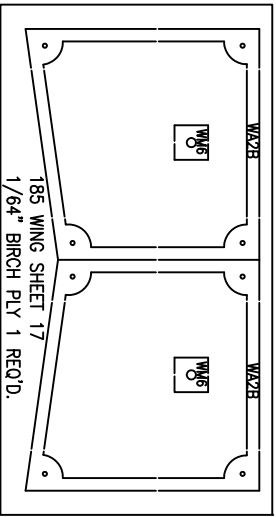

4" WIDE x 7 1/2" LG. x 1/64" THK. Birch Ply ONE (1) REQ'D.

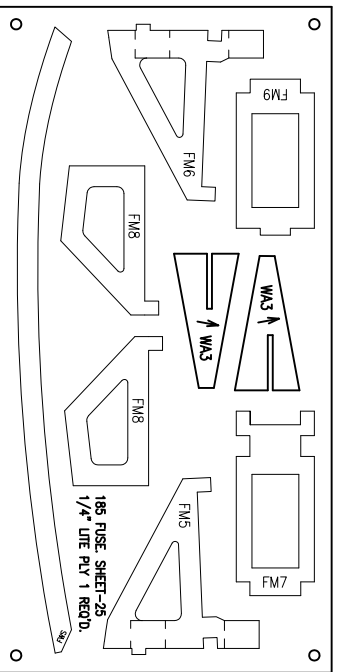

6" WIDE x 12" LONG x 1/4" THICK Lite Ply ONE (1) REQUIRED

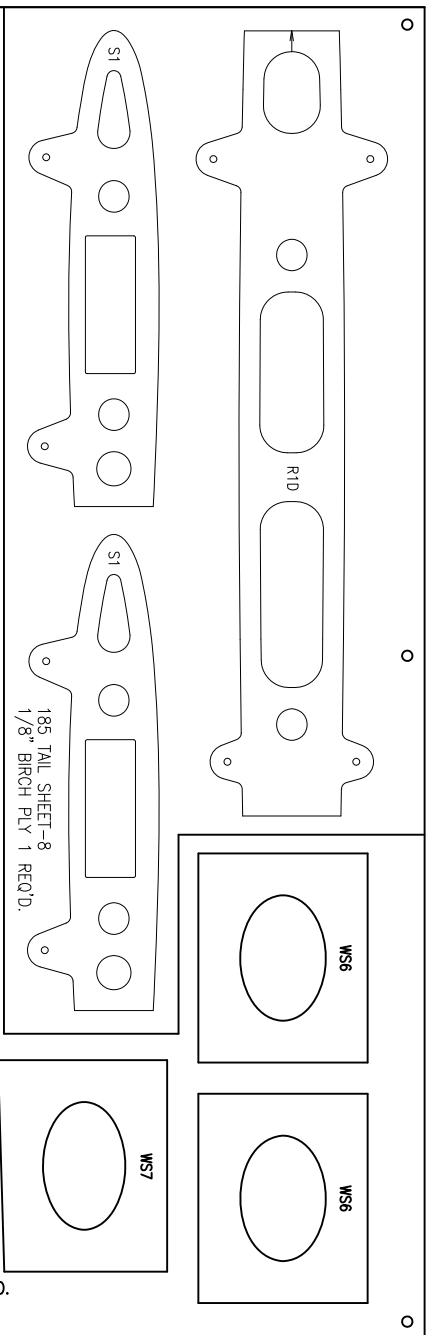

185 WING SHEET-18
1/8" BIRCH PLY 1 REQ'D.

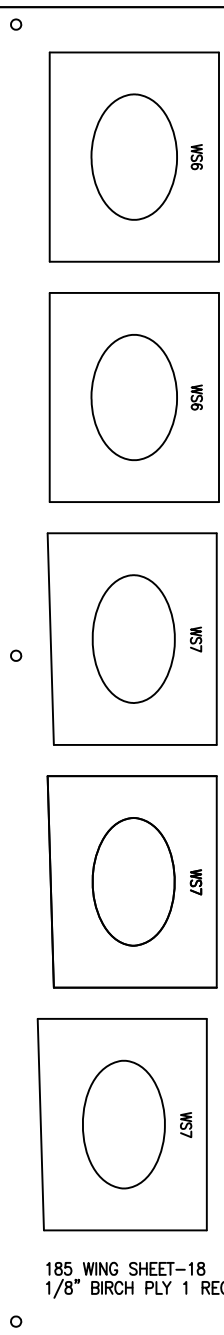

12" WIDE x 24" LONG x 1/8" THICK Birch Ply ONE (1) REQUIRED

185 WING PARTS SHEET-20

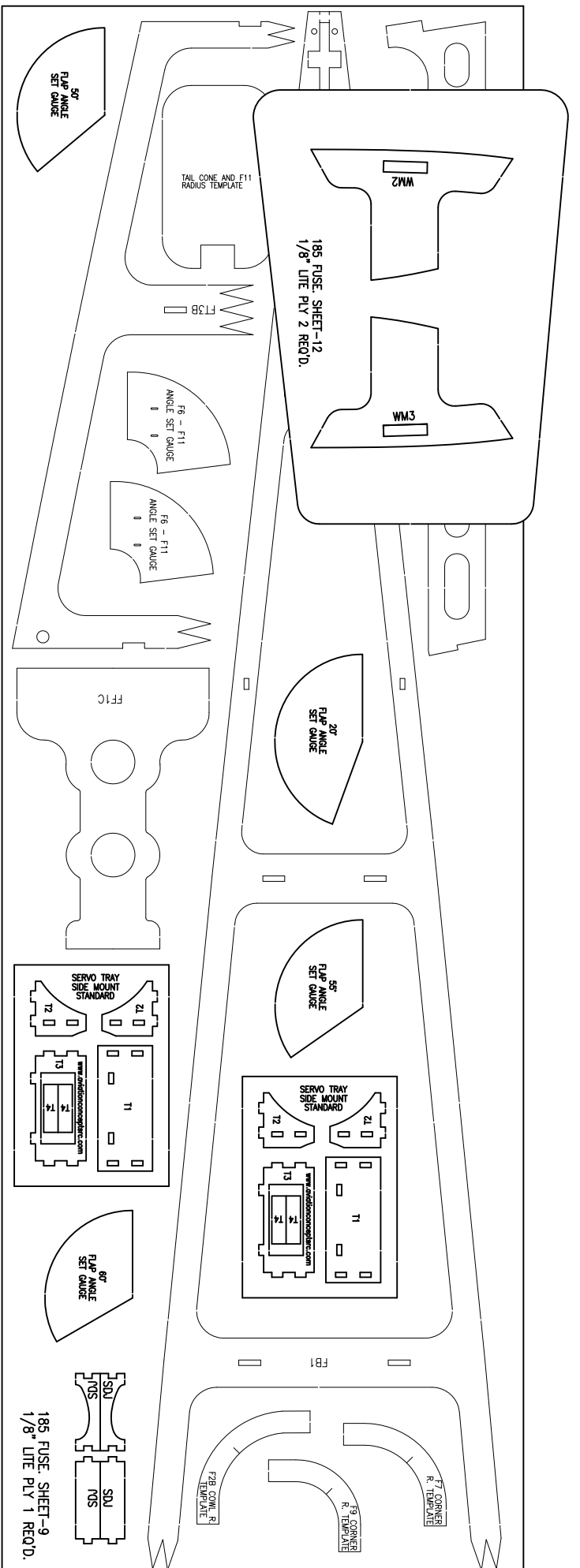

12" WIDE x 36" LONG x 1/8" THICK LITE PLY ONE (1) REQUIRED

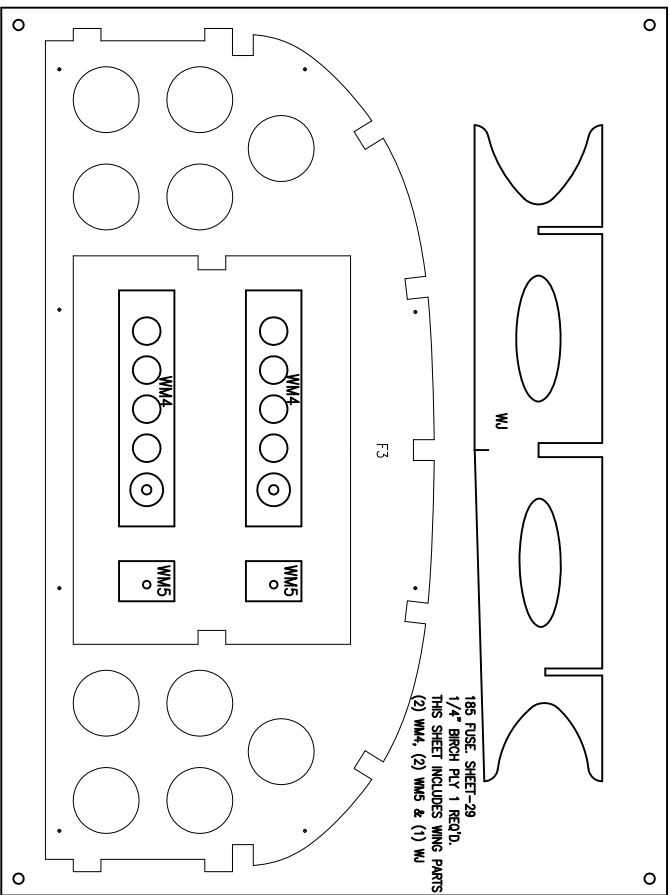

12" WIDE x 16" LONG x 1/4" THICK BIRCH PLY ONE (1) REQUIRED

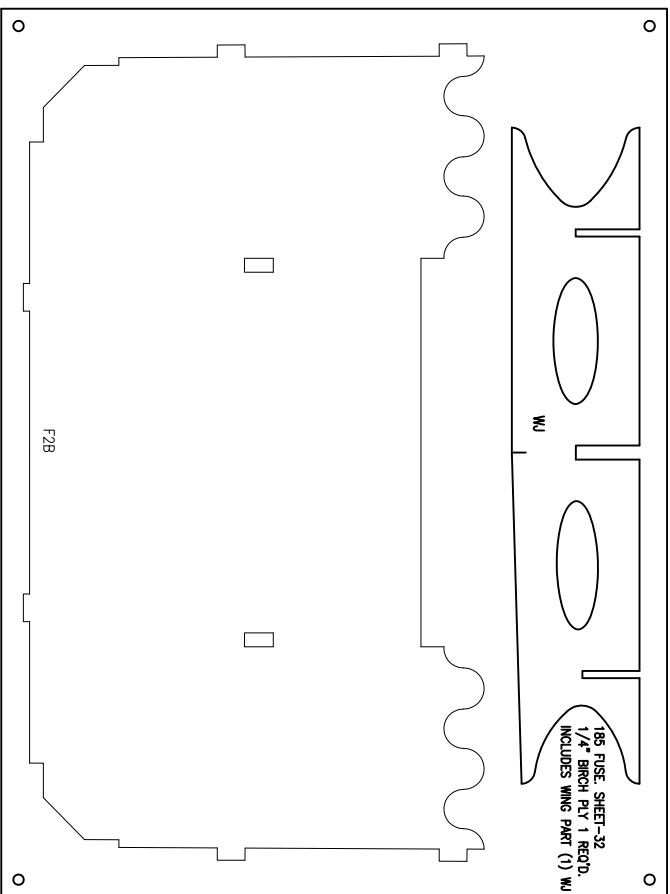

12" WIDE x 16" LONG x 1/4" THICK BIRCH PLY ONE (1) REQUIRED

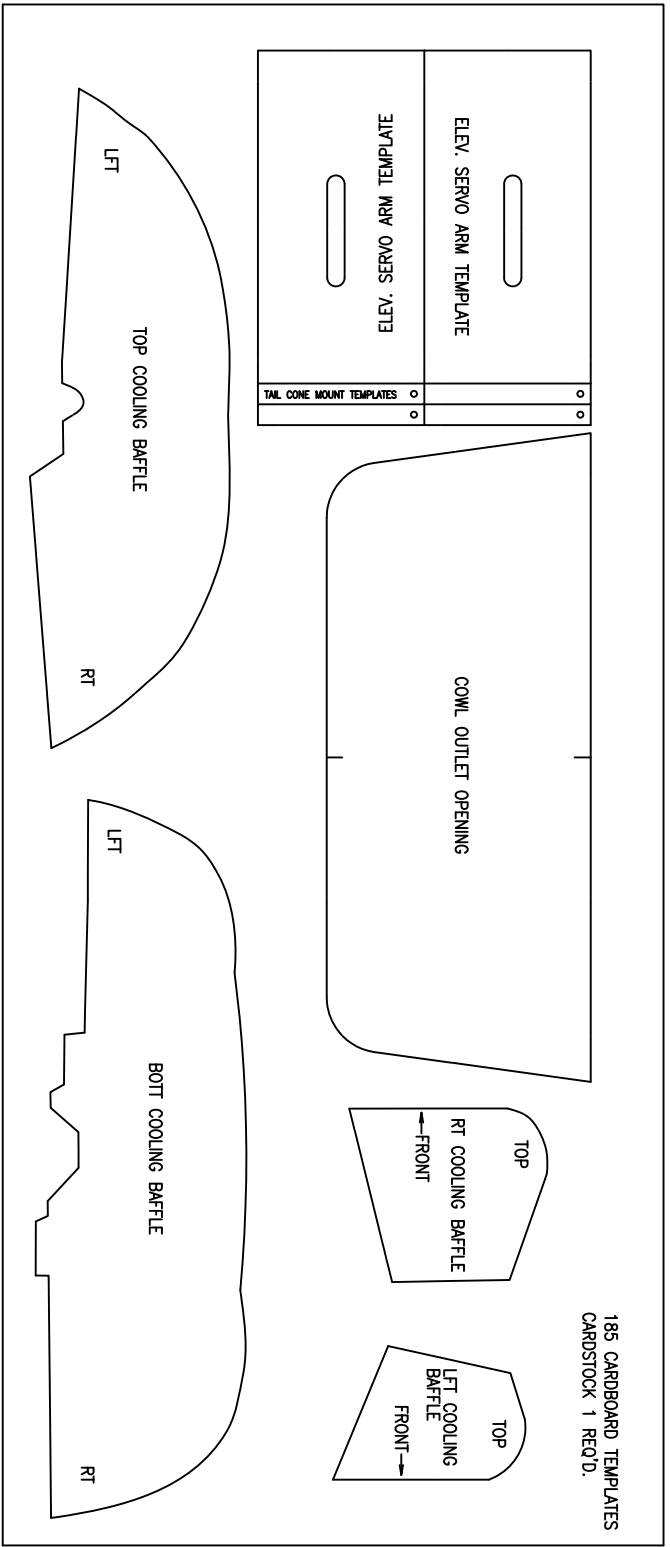

11" WIDE x 28" LONG CARDSTOCK ONE (1) REQUIRED

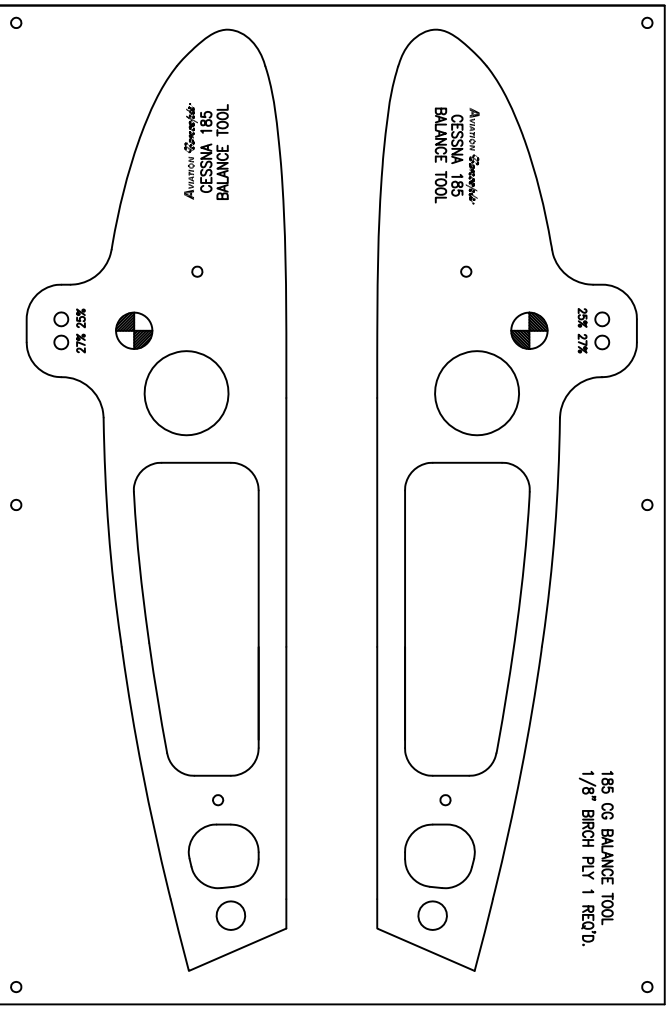

12" WIDE x 18" LONG x 1/8" THICK BIRCH PLY ONE (1) REQUIRED

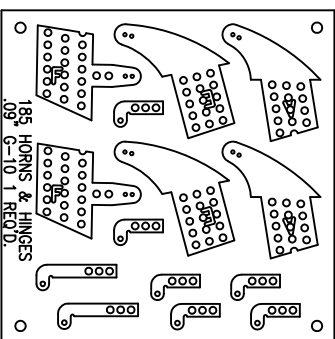
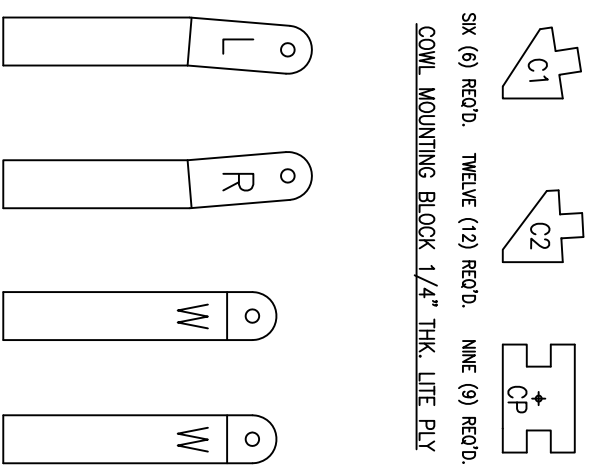

6" x 6" x 3/32" THK. G-10 ONE (1) REQUIRED



STRUT AIRFOIL PIECES

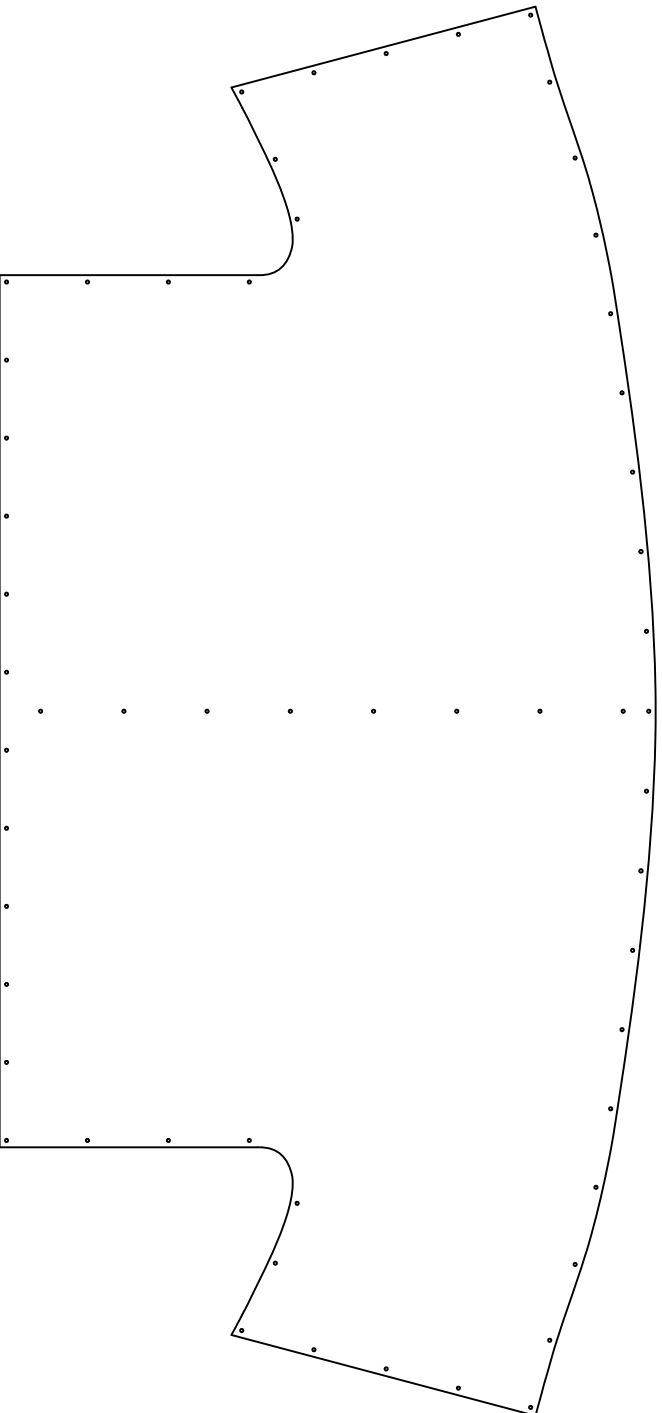
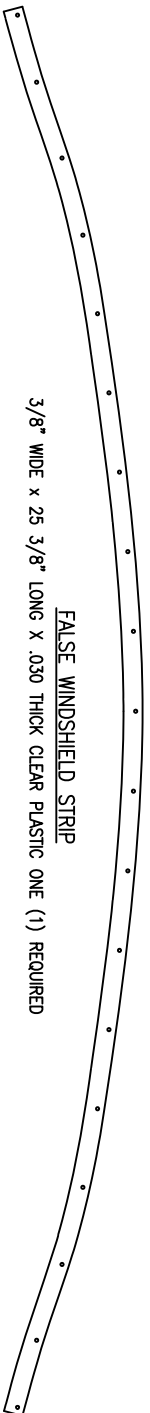
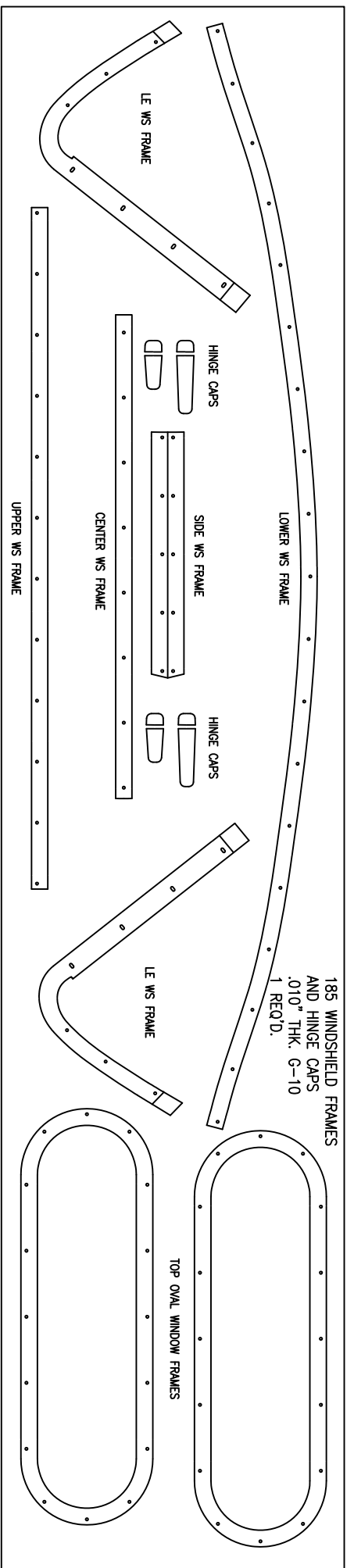

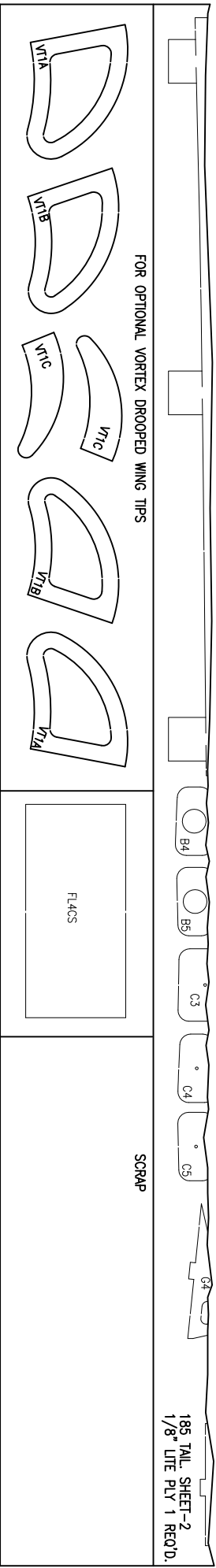
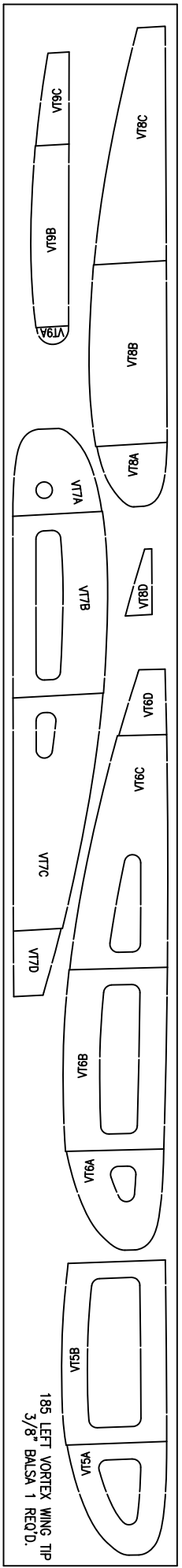
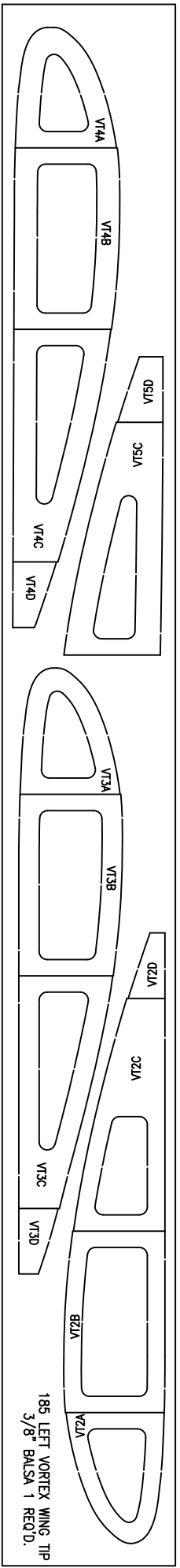
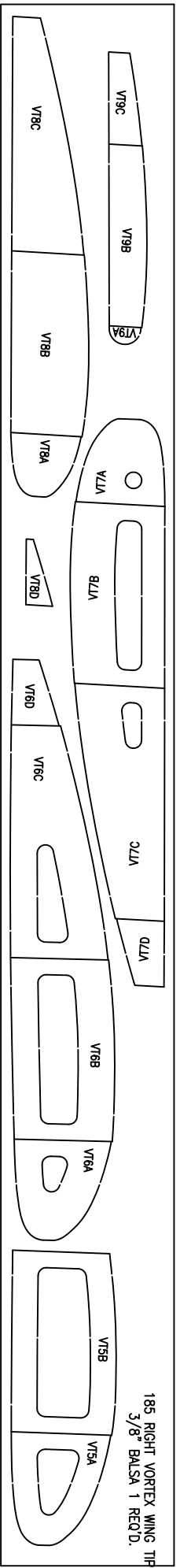
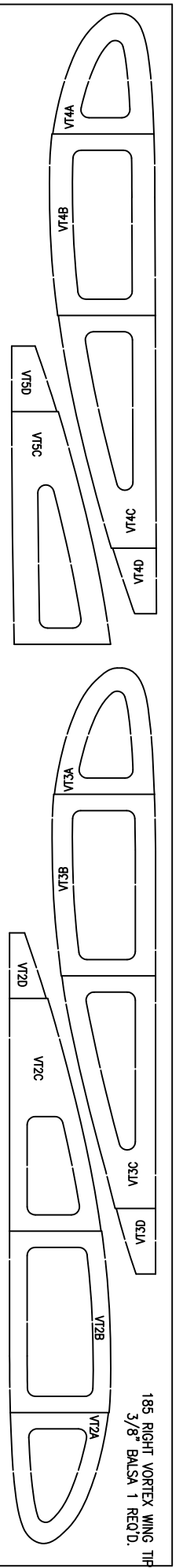

12" WIDE x 36" LONG x 1/8" THICK LITE PLY ONE (1) REQUIRED