

Geotechnical investigation and testing — Field testing

Part 12: Mechanical cone penetration test (CPTM) (ISO 22476-12:2009)

ICS 93.020

National foreword

This British Standard is the UK implementation of EN ISO 22476-12:2009.

The UK participation in its preparation was entrusted to Technical Committee B/526/3, Site investigation and ground testing.

A list of organizations represented on this committee can be obtained on request to its secretary.

This publication does not purport to include all the necessary provisions of a contract. Users are responsible for its correct application.

Compliance with a British Standard cannot confer immunity from legal obligations.

This British Standard was published under the authority of the Standards Policy and Strategy Committee on 31 October 2009.

© BSI 2009

ISBN 978 0 580 54688 4

Amendments/corrigenda issued since publication

Date	Comments

ICS 93.020

English Version

Geotechnical investigation and testing - Field testing - Part 12:
Mechanical cone penetration test (CPTM) (ISO 22476-12:2009)

Reconnaissance et essais géotechniques - Essais en place
- Partie 12: Essai de pénétration statique au cône à pointe
mécanique (ISO 22476-12:2009)

Geotechnische Erkundung und Untersuchung -
Felduntersuchungen - Teil 12: Drucksondierungen mit
mechanischen Messwertaufnehmern (ISO 22476-12:2009)

This European Standard was approved by CEN on 16 April 2009.

CEN members are bound to comply with the CEN/CENELEC Internal Regulations which stipulate the conditions for giving this European Standard the status of a national standard without any alteration. Up-to-date lists and bibliographical references concerning such national standards may be obtained on application to the CEN Management Centre or to any CEN member.

This European Standard exists in three official versions (English, French, German). A version in any other language made by translation under the responsibility of a CEN member into its own language and notified to the CEN Management Centre has the same status as the official versions.

CEN members are the national standards bodies of Austria, Belgium, Bulgaria, Cyprus, Czech Republic, Denmark, Estonia, Finland, France, Germany, Greece, Hungary, Iceland, Ireland, Italy, Latvia, Lithuania, Luxembourg, Malta, Netherlands, Norway, Poland, Portugal, Romania, Slovakia, Slovenia, Spain, Sweden, Switzerland and United Kingdom.



EUROPEAN COMMITTEE FOR STANDARDIZATION
COMITÉ EUROPÉEN DE NORMALISATION
EUROPÄISCHES KOMITEE FÜR NORMUNG

Management Centre: Avenue Marnix 17, B-1000 Brussels

Foreword

This document (EN ISO 22476-12:2009) has been prepared by Technical Committee CEN/TC 341 "Geotechnical Investigation and Testing" the secretariat of which is held by ELOT, in collaboration with Technical Committee ISO/TC 182 "Geotechnics".

This European Standard shall be given the status of a national standard, either by publication of an identical text or by endorsement, at the latest by November 2009, and conflicting national standards shall be withdrawn at the latest by November 2009.

Attention is drawn to the possibility that some of the elements of this document may be the subject of patent rights. CEN [and/or CENELEC] shall not be held responsible for identifying any or all such patent rights.

According to the CEN/CENELEC Internal Regulations, the national standards organizations of the following countries are bound to implement this European Standard: Austria, Belgium, Bulgaria, Cyprus, Czech Republic, Denmark, Estonia, Finland, France, Germany, Greece, Hungary, Iceland, Ireland, Italy, Latvia, Lithuania, Luxembourg, Malta, Netherlands, Norway, Poland, Portugal, Romania, Slovakia, Slovenia, Spain, Sweden, Switzerland and the United Kingdom.

Contents

Page

Foreword.....	iv
Introduction	v
1 Scope	1
2 Normative references	1
3 Terms, definitions, symbols and abbreviated terms.....	2
3.1 Terms and definitions.....	2
3.2 Symbols and abbreviated terms	6
4 Equipment	6
4.1 Cone penetrometer load sensors.....	6
4.2 Tolerances	6
4.3 Surface roughness	7
4.4 Cone penetrometer	7
4.5 Cone	8
4.6 Friction sleeve.....	9
4.7 Push rods	11
4.8 Inner rods	11
4.9 Measuring system.....	11
4.10 Thrust machine	12
5 Test procedures	12
5.1 Selection of type of cone penetrometer test.....	12
5.2 Selection of equipment and procedures	13
5.3 Position and level of thrust machine	15
5.4 Preparation	15
5.5 Pushing of the cone penetrometer	15
5.6 Use of friction reducer.....	15
5.7 Frequency of logging parameters.....	15
5.8 Measurement of cone penetration force for discontinuous penetration testing	15
5.9 Measurement of cone penetration force for continuous testing	16
5.10 Measurement of sleeve friction force for discontinuous testing with M2 cone penetrometers	16
5.11 Measurement of total penetration force for discontinuous testing.....	16
5.12 Measurement of total penetration force for continuous testing (TM4)	16
5.13 Measurement of the penetration length	16
5.14 Test completion	16
5.15 Equipment checks and calibrations	17
6 Test results	17
6.1 Measured parameters.....	17
6.2 Calculated parameters	17
7 Reporting	17
7.1 General.....	17
7.2 Reporting of test results	17
7.3 Presentation of test results	20
Annex A (normative) Maintenance, checks and calibration	21
Bibliography	23

Foreword

ISO (the International Organization for Standardization) is a worldwide federation of national standards bodies (ISO member bodies). The work of preparing International Standards is normally carried out through ISO technical committees. Each member body interested in a subject for which a technical committee has been established has the right to be represented on that committee. International organizations, governmental and non-governmental, in liaison with ISO, also take part in the work. ISO collaborates closely with the International Electrotechnical Commission (IEC) on all matters of electrotechnical standardization.

International Standards are drafted in accordance with the rules given in the ISO/IEC Directives, Part 2.

The main task of technical committees is to prepare International Standards. Draft International Standards adopted by the technical committees are circulated to the member bodies for voting. Publication as an International Standard requires approval by at least 75 % of the member bodies casting a vote.

Attention is drawn to the possibility that some of the elements of this document may be the subject of patent rights. ISO shall not be held responsible for identifying any or all such patent rights.

ISO 22476-12 was prepared by the European Committee for Standardization (CEN) Technical Committee CEN/TC 341, in collaboration with ISO Technical Committee TC 182, *Geotechnics*, Subcommittee SC 1, *Geotechnical investigation and testing*, in accordance with the Agreement on technical cooperation between ISO and CEN (Vienna Agreement).

ISO 22476 consists of the following parts, under the general title *Geotechnical investigation and testing — Field testing*:

- *Part 2: Dynamic probing*
- *Part 3: Standard penetration test*
- *Part 4: Ménard pressuremeter test*
- *Part 5: Flexible dilatometer test*
- *Part 7: Borehole jack test*
- *Part 10: Weight sounding test* [Technical Specification]
- *Part 11: Flat dilatometer test* [Technical Specification]
- *Part 12: Mechanical cone penetration test (CPTM)*

Electrical cone and piezocone penetration tests, self-boring pressuremeter test, full displacement pressuremeter test, and field vane test are to form the subjects of future parts 1, 6, 8 and 9.

Introduction

The mechanical cone penetration test (CPTM) consists of pushing a cone penetrometer, by means of a series of push rods, into the soil at a constant rate of penetration. During penetration, measurements of cone penetration resistance, total penetration resistance and/or sleeve friction can be recorded. The test results can be used for interpretation of stratification, classification of soil type and evaluation of geotechnical parameters.

Cone resistance is the term used in practice; however, *cone penetration resistance* is a more accurate description of the process, and is the term used in this part of ISO 22476.

Geotechnical investigation and testing — Field testing —

Part 12: Mechanical cone penetration test (CPTM)

1 Scope

This part of ISO 22476 specifies a mechanical cone penetration test (CPTM), including equipment requirements, execution and reporting. The results from such geotechnical testing are especially suited to the qualitative and/or quantitative determination of a soil profile — together with direct investigations — or as a relative comparison with other *in situ* tests.

The results from a cone penetration test can in principle be used to evaluate stratification, soil type, and geotechnical parameters such as soil density, shear-strength parameters and deformation and consolidation characteristics.

This part of ISO 22476 specifies the following features:

- type of cone penetration test (see Table 1);
- application class (see Table 2);
- penetration length or penetration depth;
- elevation of the ground surface or underwater ground surface at the location of the cone penetration test with reference to a datum;
- location of the cone penetration test relative to a reproducible fixed location reference point.

NOTE The planning and evaluation of an investigation programme and the application of its results to design are covered by EN 1997-1 and EN 1997-2.

2 Normative references

The following referenced documents are indispensable for the application of this document. For dated references, only the edition cited applies. For undated references, the latest edition of the referenced document (including any amendments) applies.

ISO 8503 (all parts), *Preparation of steel substrates before application of paints and related products — Surface roughness characteristics of blast-cleaned steel substrates*

ISO 10012:2003, *Measurement management systems — Requirements for measurement processes and measuring equipment*

3 Terms, definitions, symbols and abbreviated terms

For the purposes of this document, the following terms, definitions, symbols and abbreviated terms apply.

3.1 Terms and definitions

3.1.1

average surface roughness

R_a
average deviation between the real surface of the probe and a medium reference plane placed along the surface of the probe

3.1.2

cone

conically shaped bottom part of the cone penetrometer

NOTE When the penetrometer is pushed into the ground, the cone penetration resistance is transferred through the cone by inner rods to the measuring device at ground level.

3.1.3

cone penetration test

CPT

pushing of a cone penetrometer at the end of a series of cylindrical push rods into the ground at a constant rate of penetration

3.1.3.1

electrical CPT

CPTU

cone penetration test in which forces are measured electrically in the cone penetrometer

NOTE Electrical CPT and piezocone (CPTU) tests are to form the subject of a future part 1 of ISO 22476.

3.1.3.2

mechanical CPT

CPTM

CPT where forces are measured mechanically or electrically at ground level

3.1.4

cone penetrometer

assembly containing cone, friction sleeve (optional), connection to the push rods and measuring devices for the determination of the cone penetration resistance and, if applicable, the total resistance and/or local side friction

3.1.5

cone penetration resistance

cone resistance

resistance to the penetration of the cone

3.1.6

continuous penetration testing

test method in which cone penetration resistance is measured while cone and push rods are moving continuously until stopped for the addition of a push rod

3.1.7

discontinuous penetration testing

test method in which cone penetration resistance and, optionally, sleeve friction are measured during a penetration stop of the push rods

3.1.8
force acting on the friction sleeve

F_s
 force that will be obtained by subtracting the measured force on the cone from the measured force on the cone and friction sleeve

3.1.9
friction ratio

R_f
 ratio of sleeve friction to cone penetration resistance measured at the same depth, expressed as a percentage:

$$R_f = \frac{f_s}{q_c} \times 100 \%$$

NOTE In some cases the inverse of the friction ratio, called the *friction index*, is used.

3.1.10
friction reducer

local and symmetrical enlargement of the diameter of a push rod to reduce the friction along the push rods

3.1.11
friction sleeve

section of the cone penetrometer where sleeve friction is determined

3.1.12
inner rods

solid rods sliding inside the push rods and transferring the forces from the cone and, optionally, the friction sleeve, to the measuring system

3.1.13
measured cone penetration resistance

q_c
 division of the measured force, Q_c , on the cone by the cross-sectional area, A_c :

$$q_c = \frac{Q_c}{A_c}$$

NOTE The measured cone penetration resistance obtained from a mechanical CPT can differ from that obtained from an electrical CPT.

3.1.14
measured sleeve friction

f_s
 force, F_s , acting on the friction sleeve divided by the area of the sleeve, A_s :

$$f_s = \frac{F_s}{A_s}$$

NOTE The measured sleeve friction obtained from a mechanical CPT test can be different from the value obtained from an electrical CPT test.

3.1.15
measured total penetration force

Q_t
 force needed to push cone and rods together into the soil

3.1.16
measuring system

all sensors and auxiliary parts used to transfer and/or store the signals generated during the cone penetration test

NOTE The force on the cone and, if applicable, the total penetration resistance and/or sleeve friction are measured with manometers or with electrical load sensors.

3.1.17
penetration depth

z
depth of the base of the cone, relative to a fixed horizontal plane

See Figure 1.

NOTE 1 It is expressed in metres.

NOTE 2 With mechanical CPT, penetration depth cannot be determined, as there is no inclinometer measurement for depth correction.

3.1.18
penetration length

l
sum of the lengths of the push rods and the cone penetrometer, reduced by the height of the conical part, relative to a fixed horizontal plane

See Figure 1.

NOTE 1 It is expressed in metres.

NOTE 2 The fixed horizontal plane usually corresponds with a horizontal plane through the ground surface at the location of the test.

3.1.19
push rod

part of a string of rods for the transfer of forces to the cone penetrometer

3.1.20
thrust machine

equipment that pushes the cone penetrometer and rods into the ground at a constant rate of penetration

NOTE The required reaction for the thrust machine can be supplied by dead weights and/or soil anchors.

3.1.21
total side friction force

Q_{st}
force needed to overcome the side friction on the push rods, when these are pushed into the ground

NOTE The total side friction force is obtained by subtracting the force on the cone (Q_c) from the measured total penetration force (Q_t):

$$Q_{st} = Q_t - Q_c$$

3.1.22
zero drift

absolute difference between the zero readings of a measuring system at the start and after completion of a cone penetration test

3.1.23
zero reading

stable output of a measuring system when there is zero load on the sensor, i.e. the parameter to be measured has a value of zero, while any auxiliary power supply required to operate the measuring system is switched on

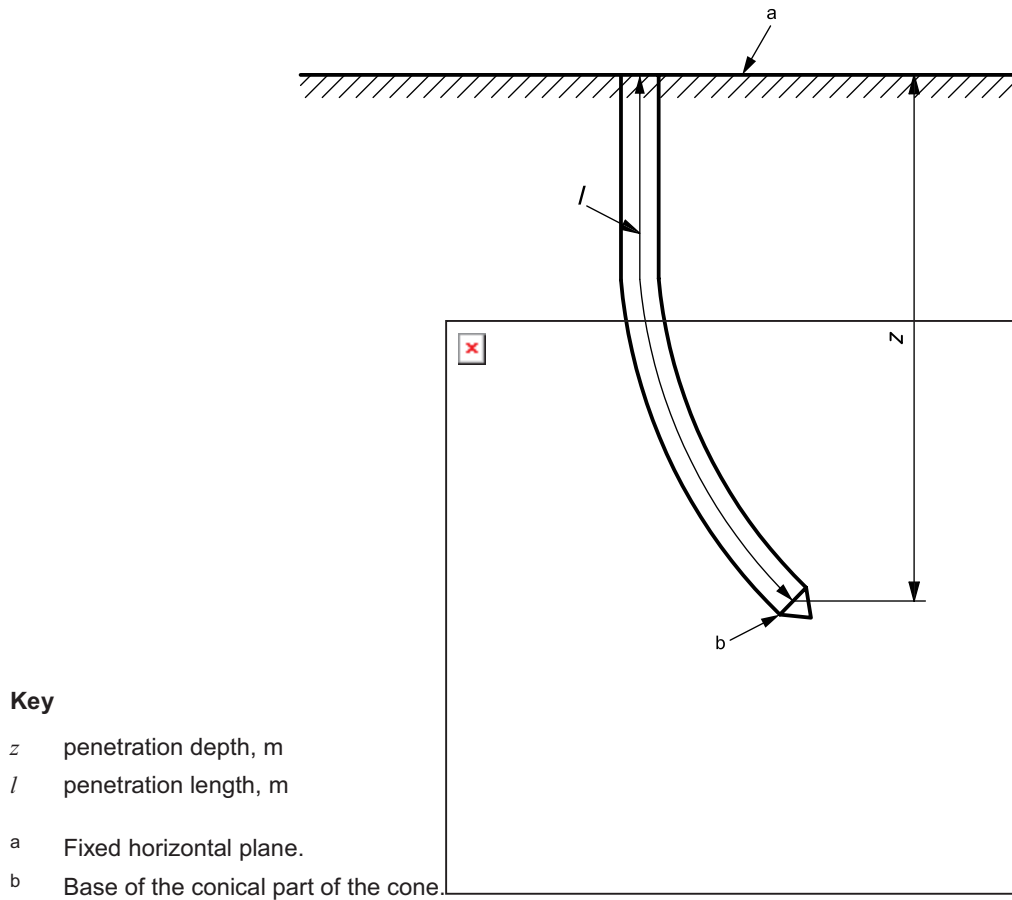

Figure 1 — Penetration length and depth

3.2 Symbols and abbreviated terms

A_c	cross-sectional projected area of cone	mm ²
A_s	cross-sectional area of friction sleeve	mm ²
d_c	diameter of cylindrical upper part of cone	mm
d_2	diameter of friction sleeve	mm
F_s	axially measured force on friction sleeve	kN
f_s	measured sleeve friction	MPa
h_c	height of conical part of cone	mm
h_e	length of cylindrical extension of cone	mm
l	penetration length	m
l_s	length of friction sleeve	mm
M1, M2, M4	types of cone penetrometer	—
Q_c	axially measured force on cone	kN
Q_{st}	total side friction force	kN
Q_t	measured total penetration force	kN
q_c	measured cone penetration resistance	MPa
R_a	average surface roughness	μm
R_f	friction ratio	%
TM1 ... TM4	test methods 1 to 4	—
t	time	s
z	penetration depth	m

4 Equipment

4.1 Cone penetrometer load sensors

The cone penetrometer has no internal load sensors, as measurements are made at ground level. The axis of all parts of the cone penetrometer shall be coincident.

4.2 Tolerances

The dimensional tolerances mentioned in this clause are operational tolerances. Manufacturing tolerances should be stricter.

The tolerance on surface roughness is a manufacturing tolerance.

4.3 Surface roughness

The surface roughness refers to average roughness, R_a , determined by a surface profile comparator according to ISO 8503 and/or equivalent standard. The intention of the surface roughness requirement is to prevent the use of an “unusually smooth” or “unusually rough” friction sleeve. Steel, including hardened steel, is subject to wear in soil (in particular sands) and the friction sleeve develops its own roughness with use. It is therefore important that the roughness at manufacture approach the roughness acquired upon use. It is believed that the surface roughness requirement will in practice usually be met for common types of steel used for penetrometer manufacture and for common ground conditions (sand and clay).

4.4 Cone penetrometer

According to their geometry, three types of cone penetrometer are considered:

- M1 (mantle), used for measuring cone penetration resistance;
- M2 (friction sleeve mantle), used for measuring cone penetration resistance and local side friction;
- M4 (simple cone), used for measuring cone penetration resistance.

NOTE The M3 cone penetrometer is a type no longer used in practice and it is therefore not addressed by this part of ISO 22476. For continuity purposes, the relevant cone penetrometer types have not been renamed.

Other types of penetrometer, not considered in this part of ISO 22476, may be used, but if so, shall be mentioned in the test results, together with the type's specifications.

The geometry of the relevant penetrometers is shown in Figures 2, 3 and 4. The push-out positions for M1 and M4 cone penetrometers are indicated in Figures 2 and 4 by “ Q_c ”, while the M2 cone penetrometer shown in Figure 3 has two push-out positions, indicated as “ Q_c ” and “ $Q_c + Q_{st}$ ”.

For a cone penetrometer with a friction sleeve, no part of the cone penetrometer shall project beyond the sleeve diameter. The cross-sectional area of the top end of the friction sleeve shall not be smaller than the cross-sectional area of the lower end.

The moving parts of the cone penetrometer (mantle, friction sleeve) shall be clean and lubricated in order to enable free movement before testing.

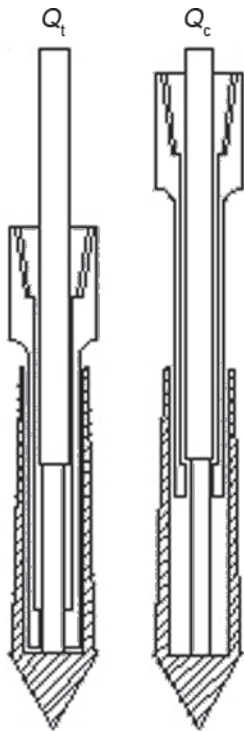

Figure 2 —
 M1 cone penetrometer
 (mantle)

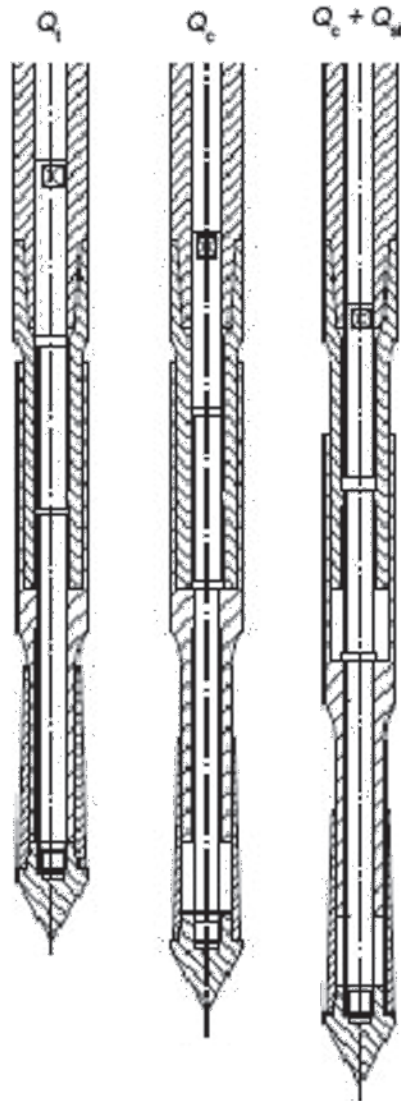

Figure 3 —
 M2 cone penetrometer
 (friction sleeve mantle)

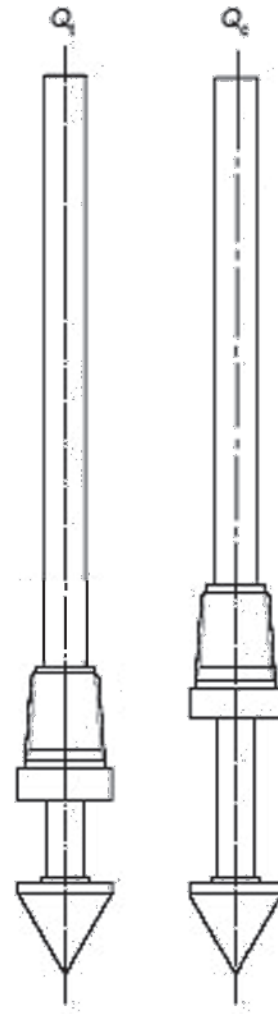

Figure 4 —
 M4 cone penetrometer
 (simple cone)

4.5 Cone

The cones of M1 and M2 cone penetrometers consist of a conical part with a shoulder and an inward-tapered cylindrical extension. The cone of an M4 penetrometer consists of a conical part with a shoulder, which is directly connected to the inner rods, without a cylindrical extension.

The cone shall have a nominal apex angle of 60°.

Cones with an angle between 60° and 90° are permitted for soil profiling if reported in the test report. Interpretation of test results in terms of engineering parameters can only be performed if specific correlations for this type of cone have been established.

The cross-sectional area of standard cones shall be 1 000 mm², which corresponds to a diameter of 35,7 mm.

The outer diameter of the shoulder shall be within the tolerance requirement shown in Figure 5:

$$35,3 \text{ mm} \leq d_c \leq 36,0 \text{ mm}$$

The length of the shoulder shall be within the following tolerance requirement:

$$2,0 \text{ mm} \leq h_e \leq 5,0 \text{ mm}$$

The height of the conical section shall be within the following tolerance requirement:

$$24,0 \text{ mm} \leq h_c \leq 31,2 \text{ mm}$$

The surface of the cone shall be smooth.

The cone should be manufactured to a surface roughness, R_a , of less than 5 μm .

The cone shall not be used if it is asymmetrically worn, even if it otherwise fulfils the tolerance requirements.

Dimensions in millimetres

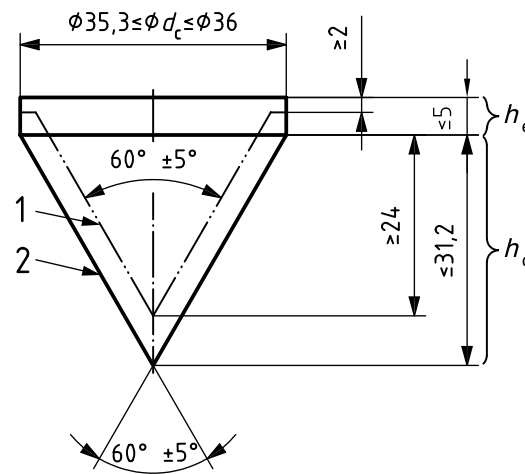

Key

- 1 minimum shape of cone after wear
- 2 maximum shape of cone

Figure 5 — Tolerance requirements for use of cone penetrometer

Depending on ground conditions, cones with an outer diameter between 25 mm ($A_c = 500 \text{ mm}^2$) and 80 mm ($A_c = 5\,027 \text{ mm}^2$) are permitted. In this case, the geometry of the cone shall be adjusted proportionally to the diameter. The geometry of the friction sleeve should be adjusted to obtain comparable results. The use of a cone with $A_c \neq 1\,000 \text{ mm}^2$ shall be reported.

4.6 Friction sleeve

The friction sleeve shall be placed above the cone.

The nominal surface area shall be 15 000 mm^2 .

The geometry and tolerances of the friction sleeve shall be within the tolerance requirements shown in Figure 6:

$$d_c \leq d_2 < d_c + 0,35 \text{ mm}$$

and

$$d_2 < 36,1 \text{ mm}$$

The length of the cylindrical part shall be within the following tolerance requirement:

$$132,5 \text{ mm} < l_s \leq 135 \text{ mm}$$

Dimensions in millimetres

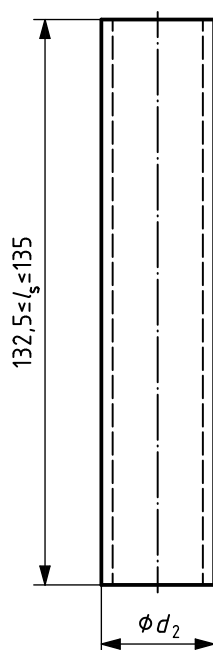

$$A_s = 15\,000 \text{ mm}^2$$

$$d_2 \geq d_c$$

$$d_2 < d_c + 0,35$$

$$d_2 < 36,1$$

Key

- A_s surface area of friction sleeve
- l_s length of friction sleeve
- d_c diameter of cone
- d_2 diameter of friction sleeve

Figure 6 — Tolerance requirements for friction sleeve

The friction sleeve shall be manufactured to an average surface roughness, R_a , of $0,4 \mu\text{m} \pm 0,25 \mu\text{m}$, measured in the longitudinal direction.

The friction sleeve shall not be used if a visual check indicates that it is scratched, asymmetrically worn or unusually rough, even if it otherwise fulfils the tolerance requirements.

Friction sleeves with an external diameter between 25 mm and 80 mm are permitted for special purposes if used with cones of the corresponding diameter without the application of correction factors. The ratio of the length and the diameter should preferably be 3,75. Ratios of 3 to 5 are allowed.

NOTE Wear of the cone can affect the measurement of sleeve friction.

4.7 Push rods

The push rods shall have the same diameter as the cone for at least 400 mm, measured from the cone base for cones with a base area of $1\,000 \text{ mm}^2$. For other cone sizes, this distance shall be scaled linearly in proportion to the diameter.

The push rods shall present no protruding parts at their inner side in order to allow free movement of the inner rods.

The straightness of the push rods, as specified below, shall be determined at regular intervals. Before each use, the straightness shall be verified by one of the methods in A.1.1:

- none of the five lower rods shall deviate more than 1 mm from the centreline;
- the other rods shall not deviate more than 2 mm.

The requirements above are valid for 1 m long rods. If other lengths of rod are used for special purposes, then the requirements should be adjusted accordingly.

Friction along the push rods may be reduced by a local increase in the rod diameter (friction reducer). Friction may also be reduced by the use of contracted rods, situated at least 400 mm above the cone base.

Above ground level, the push rods should be guided by rollers, a casing or a similar device in order to reduce the risk of buckling. The push rods may also be guided by a casing in water or soft strata to avoid buckling.

4.8 Inner rods

The straightness of the inner rods must be secured in order to allow smooth movement, without any obstruction, within the push rods. The clearance between inner rods and push rods shall be 0,5 mm to 1 mm. If the rods are not screwed together, the tip of the inner rods shall be squared (at right angles) and have a smooth surface.

4.9 Measuring system

The force acting on the cone and, if applicable, the force on the cone and on the friction sleeve, as well as the total penetration force, shall be measured by suitable devices in accordance with Table 1.

The forces measured on the cone and, if applicable, the friction sleeve during penetration are transferred by the inner rods to the measuring device at surface level.

One of the following types of measuring system (type a, b or c) shall be used.

a) Type a

This consists of manometers measuring the hydraulic pressures generated by the force acting on the cone and transferred to the top of the inner rods and, if applicable, by the force on the cone and friction sleeve, and by the total force on the push rods. The use of two significantly different ranges for manometers simultaneously and switching frequently to the appropriate range is recommended for this type of measuring device.

b) Type b

This is comprised of electrical sensors measuring the hydraulic pressures generated by the force acting on the cone and transferred to the top of the inner rods and, if applicable, by the force on the cone and friction sleeve, and by the total force on the push rods.

c) Type c

This type comprises electrical sensors directly measuring the forces on the cone penetrometer. The use of separate devices to measure the forces needed for determining cone penetration resistance, sleeve friction and total penetration resistance is recommended for this type of measuring system.

Independent of the measuring system used, the test results shall be directly accessible during the test. Measured pressures and/or forces shall be recorded, and the maximum value for each stroke shall be stored as a nominal value of the measured parameter.

4.10 Thrust machine

The equipment shall be able to penetrate the cone penetrometer at the standard rate of penetration of (20 ± 5) mm/s, and it shall be loaded or anchored in so that movements of the thrust machine relative to ground level are limited while the penetration occurs. Hammering or rotating of the penetration rods during measurements is not allowed.

Required reaction (counterweight) for the thrust machine may be supplied by dead weight and/or soil anchors.

5 Test procedures

5.1 Selection of type of cone penetrometer test

The test procedure shall be selected from those specified in Table 1.

The test type (TM1, TM2, TM3 or TM4) shall be selected according to the relevant application class given in Table 2.

Table 1 — Types of cone penetration test

Test type	Measured and derived parameters	Measurement system
TM1	Cone penetration resistance and total penetration resistance or cone penetration resistance and sleeve friction	Electrical sensor (type c, see 4.9) — discontinuous testing
TM2	Cone penetration resistance and total penetration resistance or cone penetration resistance and sleeve friction	Manometers or electrical sensor converting hydraulic pressures (types a and b, see 4.9) — discontinuous testing
TM3	Cone penetration resistance	Manometers or electrical sensor converting hydraulic pressures (types a and b, see 4.9) — discontinuous testing
TM4	Cone penetration resistance	Manometers or electrical sensor converting hydraulic pressures (types a and b, see 4.9) — continuous testing

NOTE The numbers indicating cone penetration test types TM1 to TM4 do not correspond to those of cone types M1, M2 and M4 (see 4.4), nor to the numbers identifying application classes (see Table 2).

5.2 Selection of equipment and procedures

The required accuracy is a function of the intended use of the results. Application classes have been developed to give guidance on selecting the type of CPTM and the required accuracy. The application class specifies the type of cone penetrometer to be used and the suggested use of CPTM results for given soil profiles. The use of CPTM results is stated in terms of profiling, material identification and definition of soil parameters.

Equipment and procedures shall be selected according to the required application class given in Table 2.

Table 2 — Application classes

Application class	Type of cone penetration test	Allowable minimum accuracy ^a	Suggested use	
			Soil type ^b	Interpretation ^c
5	TM1	q_c 500 kPa or 5 %	A B C D	F
		Q_t 1 kN or 5 %		G, H*
		f_s 50 kPa or 20 %		G, H*
		l 0,2 m or 2 %		G, H*
6	TM2	q_c 500 kPa or 5 %	B C D	G, H*
		Q_t 1 kN or 5 %		G, H*
		f_s 50 kPa or 20 %		G, H*
		l 0,2 m or 2 %		G, H*
7	TM3	q_c 500 kPa or 5 %	B C D	F*
	TM4	Q_t 1 kN or 5 %		F*
		f_s 50 kPa or 20 %		F*
		l 0,2 m or 2 %		F*

Application Classes 5 to 7 are those used for mechanical CPTM (Classes 1 to 4 are for electrical CPT/CPTU).

- **Class 5** is intended for the evaluation of mixed bedded soils, soil types A to D. For soil types B to D, profiling, material identification and indicative interpretation in terms of engineering parameters is achievable. For very soft layers (soil type A) only soil profiling is possible. Material identification and interpretation in terms of engineering parameters, especially for very soft layers, is only possible if complementary and relevant geological and geotechnical information is available. Tests are to be performed with a cone penetration test type TM1.
 NOTE Mixed bedded soil profiles refer to soil conditions typically containing dense and compact soils, but possibly also soft layers.
- **Class 6** is intended for the evaluation of mixed bedded soils, with soil types B to D, in terms of profiling and material identification. Evaluation of very soft layers is limited to detection of these layers. Tests are to be performed using test type TM2.
- **Class 7** is intended only for indicative profiling for mixed bedded soils, soil types B to D. No interpretation in terms of material identification and engineering parameters can be given only on the basis of these test results. Tests are to be performed using test type TM3 or TM4.

Although electrical CPT is preferred to mechanical CPT, mechanical CPT can be preferable in case of risk of damage by, for example, debris, cobbles or bedrock.

The achievable accuracy depends also on the error caused by friction between inner rods and the push rods. The order of magnitude of this error depends amongst others on the penetration length, the force on the inner rods and the inclination of the cone.

^a The allowable minimum accuracy of the measured parameter is the larger value of the two quoted. The relative accuracy applies to the measured value and not the measured range.

^b

- A Homogeneously bedded soils (typically $q_c < 2$ MPa).
- B Clays, silts and sands (typically $2 \text{ MPa} \leq q_c < 4$ MPa).
- C Clays, silts, sands and gravels (typically $4 \text{ MPa} \leq q_c \leq 10$ MPa).
- D Clays, silts, sands and gravels (typically $q_c > 10$ MPa).

^c

- F Profiling.
- F* Profiling possible if extra information is provided.
- G Profiling and material identification.
- G Indicative profiling and material identification.
- H* Interpretation in terms of engineering parameters.
- H* Indicative interpretation in terms of engineering parameters.

If all possible sources of error are added, the accuracy of the recorded measurements shall be better than the largest of the values given in Table 2. The inaccuracy evaluation shall include internal friction, errors in the data acquisition, temperature (ambient and transient) effects and dimensional errors.

Metrological confirmation shall be performed according to ISO 10012.

NOTE 1 The achievable penetration length depends on the soil conditions, the allowable penetration force, the allowable forces on the push rods and push rod connectors, the application of a friction reducer and/or push rod casing and the measuring range of the cone penetrometer.

NOTE 2 If the cone penetrometer types used are different from the standard types, interpretation in terms of engineering parameters can be performed only if specific correlations for that type of cone penetrometer have been established.

5.3 Position and level of thrust machine

The distance between the test location and the location of previous investigation points should be sufficient to prevent interaction effects.

Between cone penetration tests, a distance of 1 m is sufficient. The distance to a previous borehole should be at least 20 times the borehole diameter. Some borehole techniques, such as air drilling, may require larger distances. Nearby excavations should be avoided.

The thrust machine shall push the push rods so that the axis of the pushing force is as close to vertical as possible; the deviation from the intended axis should be less than 2°. The axis of the penetrometer shall correspond to the loading axis at the start of the penetration.

5.4 Preparation

If electrical sensors are used, the zero readings of the cone penetration resistance, the penetration length and the sleeve friction shall be recorded.

Pre-drilling may be used in dense, coarse or stone-rich layers where the penetration stops. Pre-drilling may be used in coarse top layers, sometimes in combination with casings, to prevent the borehole from collapsing.

5.5 Pushing of the cone penetrometer

During the penetration test, the cone penetrometer shall be pushed into the ground at a constant rate of penetration of (20 ± 5) mm/s. The rate shall be checked regularly.

5.6 Use of friction reducer

The use of a friction reducer is permissible. The cone penetrometer and, if relevant, the push rod shall have the same diameter for at least 400 mm, measured from the base of the cone before the introduction of the friction reducer, if applicable.

5.7 Frequency of logging parameters

The maximum length interval for measuring the parameters shall be 200 mm for discontinuous and 50 mm for continuous penetration testing.

5.8 Measurement of cone penetration force for discontinuous penetration testing

Measure the cone penetration force during a stroke of the inner rods and cone of no more than

- 70 mm for the M1 cone penetrometer,
- 35 mm for the M2 cone penetrometer, and

— 65 mm for the M4 cone penetrometer.

Record the maximum value of the measured cone penetration force during this stroke. In the case where only the cone penetration force and penetration length are measured, the interval may be smaller, or readings may be continuous.

5.9 Measurement of cone penetration force for continuous testing

For continuous testing (TM4), the cone shall remain in push-out position (see Figures 2 to 4). The push-out shall be sufficient to compensate the elastic compression of the inner rods, so that the force on the cone is totally transmitted to the inner rods.

5.10 Measurement of sleeve friction force for discontinuous testing with M2 cone penetrometers

Measure the sum of the forces acting on the cone during a second stroke not exceeding 40 mm (following the first stroke), when cone and friction sleeve are pushed into the soil. Record the maximum measured value during this stroke. Subtract the cone penetration force from this cumulative measurement to obtain the sleeve friction.

5.11 Measurement of total penetration force for discontinuous testing

Measure the total penetration force at the end of a joint stroke of push rods and inner rods with a stroke of maximum 200 mm.

5.12 Measurement of total penetration force for continuous testing (TM4)

Measure the total penetration force simultaneously with the cone penetration resistance, using a separate measuring device.

5.13 Measurement of the penetration length

Determine the level of the cone base relative to the ground level or another fixed reference system (not the thrust machine). The resolution of penetration length measurement shall be at least 10 mm.

For penetration tests of type TM1, the penetration length is measured by a sensor.

For all types of penetration tests, the penetration length should be checked manually and recorded at the end of the test.

NOTE Measured parameters for a cone penetrometer with a large inclination can deviate from the values that would have been measured if the cone penetrometer was vertical.

During the cone penetration test, any particularities or deviations from this part of ISO 22476 that could affect the results of the measurements and the corresponding penetration length shall be recorded.

5.14 Test completion

The penetration of the cone penetrometer and the push rods shall be terminated when

- the required penetration length has been reached, or
- the agreed maximum thrust or maximum capacity of the measuring system has been reached.

Possible damage to the equipment may also be a valid reason to end the test.

If measuring with electrical sensors, measure the zero readings of the measured parameters and record them after completion of the test. The zero drift of the measured parameters shall be less than the allowable minimum accuracy according to the required application class (see Table 2).

NOTE Zero drift determined from zero load output before and after testing is a measure of the correct functioning of the equipment and is used to verify if the requirements of Table 2 have been fulfilled.

The cone penetrometer shall be inspected and any excessive wear or damage shall be recorded.

5.15 Equipment checks and calibrations

Equipment checks and calibrations shall be conducted in accordance with Annex A.

6 Test results

6.1 Measured parameters

The following parameters shall be determined:

- penetration length, l ;
- force acting on the cone, Q_c ;
- total penetration force, Q_t .

6.2 Calculated parameters

The following parameters shall be calculated:

- force acting on the friction sleeve, F_s ;
- total side friction force, Q_{st} ;
- measured cone penetration resistance, q_c ;
- measured sleeve friction, f_s ;
- friction ratio, R_f .

7 Reporting

7.1 General

In the presentation of test results, the information should be easily accessible, for example, presented in tables or as a standard archive scheme. Presentation in digital form is allowed for easier data exchange.

7.2 Reporting of test results

Reporting shall be in accordance with Table 3, which specifies whether information is to be recorded in

- the field record of test results,
- the test report, or
- every table and every plot of the test results.

The field record, completed at the project site, and the test report shall include the information specified in Table 3. The test results shall be reported to enable a third party to check and understand the results.

Table 3 — Reporting of test results

To be reported	Field record	Test report	Every plot
7.2.1 General information			
a) Reference to this standard		×	×
b) Application class	×	×	×
c) Test type (TM1, TM2, TM3 or TM4)	×	×	×
d) Name of the client		×	
e) Name and location of the project		×	
f) Job identification	×	×	×
g) Name and signature of equipment operator executing the test	×		
h) Name and signature of field manager responsible for the project		×	
i) Particulars or deviations from this standard	×	×	
j) Company executing the test		×	×
k) Depth to the groundwater table (if recorded)	×	×	
l) Depth of pre-drilling or trenching depth	×	×	×
m) Description of materials encountered (if possible)	×	×	
n) Length of penetration and possible causes of any interruptions	×	×	
o) Stop criteria applied, for example target depth, maximum penetration force and indication on deviation from the vertical	×	×	
p) Method of back filling the hole, if applicable	×		
q) Observations made in the test, for example: <ul style="list-style-type: none"> — presence of stones, — noise from the pushing rods, — incidents, — buckled rods, — abnormal wear, — significant changes in zero readings. 	×	×	

Table 3 (continued)

To be reported	Field record	Test report	Every plot
7.2.2 Test location			
a) Identification of the test	×	×	×
b) Elevation of the cone penetration test		×	×
c) Local or general coordinates and/or a location diagram ^a		×	×
d) Reference system and tolerances		×	
e) Reference elevation to a known datum		×	×
7.2.3 Test equipment			
a) Cone penetrometer type (M1, M2 or M4)	×	×	×
b) Geometry and dimensions of cone penetrometer	×	×	
c) Type of thrust machine used, pushing capacity, associated jacking and anchoring systems	×	×	
d) Manufacturer of cone penetrometer		×	
e) Identification number of the penetrometer	×		
f) Measuring ranges of the transducers		×	
g) Date of last calibration of sensors		×	
7.2.4 Test procedure			
a) Date of the test	×	×	×
b) Starting time of the test	×		
c) Depth of the start of penetration with reference to the ground surface	×	×	×
7.2.5 Test results			
a) Measured parameters according to 6.1	×	×	
b) Calculated parameters according to 6.2		×	
c) Zero readings of cone penetration resistance, sleeve friction and, if applicable, total resistance before and after the test and zero drift (in engineering units), if using electrical sensors	×	×	
d) Corrections applied during data processing (e.g. zero drifts)		×	
e) Penetration length, <i>l</i> , after termination of the test and possible causes for any interruptions	×	×	×
^a The contract shall specify who is responsible for providing the coordinates and levels of investigation points.			

7.3 Presentation of test results

The test results shall be presented as profiles as a function of the penetration length.

The test results that shall be presented according to 7.2 are the following:

- cone penetration resistance versus length q_c (MPa) – l (m)
- sleeve friction versus length f_s (MPa) – l (m)
- total penetration force versus length Q_t (kN) – l (m)
- total side friction versus length Q_{st} (kN) – l (m)
- friction ratio versus length R_f (%) – l (m)

Kilopascals (kPa), instead of megapascals (MPa), may be used as the unit for cone penetration resistance and sleeve friction versus length, depending on the magnitude of the parameters.

Annex A (normative)

Maintenance, checks and calibration

A.1 Maintenance and checks

A.1.1 Linearity of push rods

Before adding a push rod, the linearity (straightness) of the rods should be checked using one of the following methods:

- holding the rod vertically and rotating it — if the rod appears to wobble, the straightness is unacceptable;
- rolling the rods on a plane surface — if, during rolling, the distance between any point on the rod and the surface exceeds the tolerances specified in 4.7, the straightness is unacceptable;
- sliding over the rod a straight hollow tube that is slightly longer than the rod and whose inner diameter is equal to the rod diameter with the tolerance specified in 4.7 — if the rod can pass through the tube without jamming, the straightness is acceptable.

If any indications of bending appear, the use of the rods should be suspended until it is ascertained, through inspection and if necessary repairs, that the straightness of the rods complies with the requirements.

The straightness of the inner rods must be assured in order to allow smooth movement, without any obstruction, within the push rods.

A.1.2 Wear and bending of the cone

The wear and bending of the cone and the friction sleeve shall be checked visually after every test to ensure that the geometry satisfies the tolerances. A standard geometrical pattern similar to a new or unused cone penetrometer may be used in this control.

A.1.3 Manometers

Before starting a CPTM, a visual check shall be performed to verify the correct indication of the zero value. The compatibility of measured values with lower and higher range manometers shall also be checked when loaded up to 70 % of the measuring range of the lower range manometer. In case of discrepancy, the manometer giving incorrect values shall be replaced, and a new check performed, after de-airing of the hydraulic measuring unit.

A.1.4 Maintenance procedures

Maintenance and calibration of the equipment shall be in accordance with Table A.1 and with the manufacturer's manual for the particular equipment.

Table A.1 — Control scheme for routine checks

Check	Start of test	End of test	Every 6 months
Verticality of thrust machine	×		
Depth sensor			×
Push rods	×		
Wear	×	×	
Zero values	×	×	
Zero drift		×	
Manometers	×		
Calibration			× ^a

^a Additionally, at intervals during long-term testing (see A.2.1).

A.2 Calibration

A.2.1 General procedures

Load cells and pressure transducers shall be calibrated, and depth sensors and manometers shall be verified regularly at the following intervals:

- at least every 6 months for pressure transducers, manometers and load cells in continuous use or after approximately 500 soundings;
- after the load measuring system has been loaded close to its capacity.

The calibrations shall include the whole measurement system, i.e. mounted transducers, data acquisition system and cables. The calibration is performed as “system calibration”, i.e. carried out using the same data acquisition system, including cables, as in the field test, representing a check of possible inherent errors of the system. During fieldwork, the equipment shall be subject to regular function controls. The regular function controls should take place at least once per location and/or once per day. If the operator suspects overloading of the load sensors (loss of calibration), a function control and possibly a re-calibration shall be carried out.

In general, the requirements presented in ISO 10012 should be followed.

A.2.2 Calibration of load cells and pressure transducers

The calibration of load cells and pressure transducers is performed by incrementally loading and unloading. Load cells and pressure transducers shall be calibrated in various measuring ranges, with special emphasis on those ranges relevant for the forthcoming tests. When a load cell/pressure transducer is calibrated, the sensors should be subjected to repeated loading cycles up to the maximum load, before the actual calibration.

A.2.3 Calibration of manometers and depth sensors

Manometers shall be calibrated at least every 6 months, as part of the whole hydraulic system. Depth sensors shall be calibrated at least every 6 months and after repair.

Bibliography

- [1] ISO 14688-2:2004, *Geotechnical investigation and testing — Identification and classification of soil — Part 2: Principles for a classification*
- [2] ISO 22475-1, *Geotechnical investigation and testing — Sampling methods and groundwater measurements — Part 1: Technical principles for execution*
- [3] ISO 22476-1, *Geotechnical investigation and testing — Field testing — Part 1: Electrical cone and piezocone penetration tests*
- [4] EN 1997-1, *Eurocode 7: Geotechnical design — Part 1: General rules*
- [5] EN 1997-2, *Eurocode 7: Geotechnical design — Part 2: Ground investigation and testing*
- [6] CASSAN, M. 1987. *Les essais in situ en mécanique des sols — tome I: Réalisation et interprétation*, Eyrolles chap. II-5-2 pp. 125 to 127
- [7] *International reference test procedure*. Report by the committee on penetration testing TC 16. ISSMFE. 1989
- [8] LUNNE, T., ROBERTSON, P.K. and POWELL, J.J.M. 1997. *Cone Penetration Testing in Geotechnical Practice*. London: E & FN Spon, an imprint of Routledge
- [9] DE BEER, E.E., GOELEN, E., HEYNEN, W.J. and JOUSTRA, K. March 1988. *Cone penetration test (CPT): International reference test procedure*. International symposium on penetration testing, 1, ISOPT-1, Orlando, Proceedings, Vol. 1 Publ.data: pp. 27-51
- [10] BERGDAHL, U. 1989. *Report of the ISSMFE Technical Committee on Penetration Testing of Soils. TC 16 with Reference Test Procedures: CPT - SPT - DP - WST*. Statens Geotekniska Institut. SGI Information 7, 49 s Linköping

BSI - British Standards Institution

BSI is the independent national body responsible for preparing British Standards. It presents the UK view on standards in Europe and at the international level. It is incorporated by Royal Charter.

Revisions

British Standards are updated by amendment or revision. Users of British Standards should make sure that they possess the latest amendments or editions.

It is the constant aim of BSI to improve the quality of our products and services. We would be grateful if anyone finding an inaccuracy or ambiguity while using this British Standard would inform the Secretary of the technical committee responsible, the identity of which can be found on the inside front cover. Tel: +44 (0)20 8996 9000. Fax: +44 (0)20 8996 7400.

BSI offers members an individual updating service called PLUS which ensures that subscribers automatically receive the latest editions of standards.

Buying standards

Orders for all BSI, international and foreign standards publications should be addressed to Customer Services. Tel: +44 (0)20 8996 9001. Fax: +44 (0)20 8996 7001 Email: orders@bsigroup.com You may also buy directly using a debit/credit card from the BSI Shop on the Website <http://www.bsigroup.com/shop>

In response to orders for international standards, it is BSI policy to supply the BSI implementation of those that have been published as British Standards, unless otherwise requested.

Information on standards

BSI provides a wide range of information on national, European and international standards through its Library and its Technical Help to Exporters Service. Various BSI electronic information services are also available which give details on all its products and services. Contact Information Centre. Tel: +44 (0)20 8996 7111 Fax: +44 (0)20 8996 7048 Email: info@bsigroup.com

Subscribing members of BSI are kept up to date with standards developments and receive substantial discounts on the purchase price of standards. For details of these and other benefits contact Membership Administration. Tel: +44 (0)20 8996 7002 Fax: +44 (0)20 8996 7001 Email: membership@bsigroup.com

Information regarding online access to British Standards via British Standards Online can be found at <http://www.bsigroup.com/BSOL>

Further information about BSI is available on the BSI website at <http://www.bsigroup.com>.

Copyright

Copyright subsists in all BSI publications. BSI also holds the copyright, in the UK, of the publications of the international standardization bodies. Except as permitted under the Copyright, Designs and Patents Act 1988 no extract may be reproduced, stored in a retrieval system or transmitted in any form or by any means – electronic, photocopying, recording or otherwise – without prior written permission from BSI.

This does not preclude the free use, in the course of implementing the standard, of necessary details such as symbols, and size, type or grade designations. If these details are to be used for any other purpose than implementation then the prior written permission of BSI must be obtained.

Details and advice can be obtained from the Copyright and Licensing Manager. Tel: +44 (0)20 8996 7070 Email: copyright@bsigroup.com