

SavvyLevel External Mount Installation Guide

Before you install SavvyLevel, please first take the time to read and understand this guide. In particular the Power requirements *Step 5* overleaf.

References to caravan in this guide also applies to campers, recreational vehicles, 4WD or trailers where SavvyLevel is intended to be installed.

The SavvyLevel External mount kit is designed to mount the SavvyLevel device externally. Useful for heavily clad caravans where improved signal performance (to the tow vehicle) is required. It comprises of a lid, base, componentry protection cradle, and one cable gland. You will need to supply silicone to complete the installation process. The external mount still requires purchase of a SavvyLevel unit.

SavvyLevel External Mount key features:

- Is strong, UV, hail, wind, stone, dust, dirt and temperature stable.
- Is IP68 rated (when properly installed) and therefore can be totally immersed in water.
- Allows manufacturer choice of connecting cable.
- Insignificant signal degradation to the tow vehicle.
- Well suited to manufacturing processes, when used as an OEM product and retrofitting.
- Hidden mounting method aesthetically appealing.
- Easily retrofittable to existing systems by customers or installers – no special equipment is required.

STEP 1 - FINDING A GOOD LOCATION

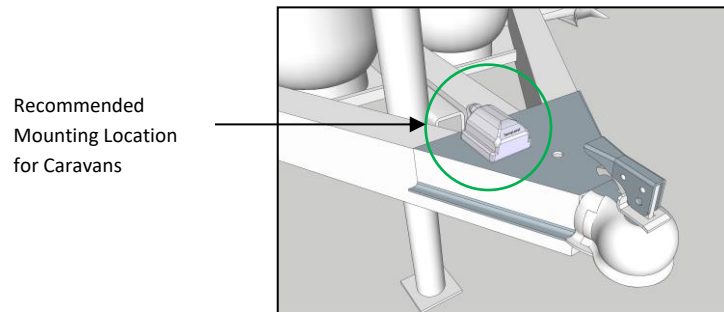

Figure 1

POINTS TO CONSIDER

SavvyLevel requires good reliable signal communication between it and the inside of your tow vehicle, where you will operate your Smartphone. Best performance can be achieved if you mount the device where there are minimal metallic obstructions. For caravans, generally the 'A' frame is a good location where there are minimal obstructions between it and the tow vehicle.

If you use the magnetic compass feature it may be affected when placed near ferrous metallic objects with associated local magnetic fields. Hall effect sensors are not affected by ferrous metals, however any residual local

magnetic fields (typical at welded joints) will alter the compass direction. If the compass feature is not being used then this becomes irrelevant. Levelling performance is not affected by magnetic fields.

SavvyLevel MUST be mounted level horizontally (less than 15°). It also must be straight and forward (**NOT ANGLED WITH THE 'A' FRAME**) – see *Figure 1 and 2*.

Please mount SavvyLevel using 4mm diameter rivets or screws (non-ferrous recommended unless compass is not required).

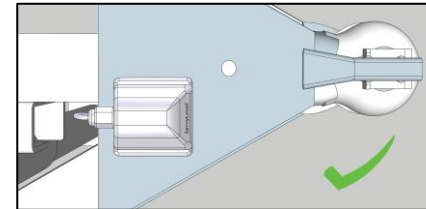

Figure 2

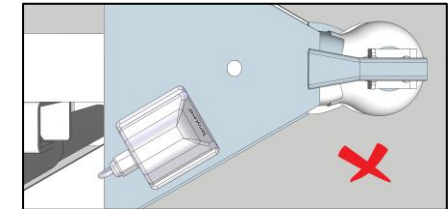

Figure 3

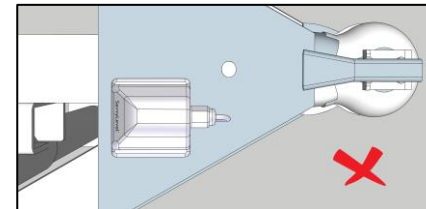

Figure 4

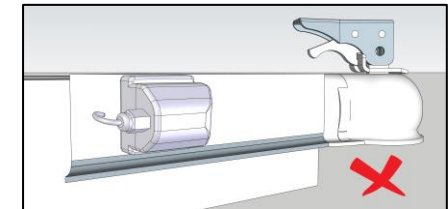

Figure 5

STEP 2 - MOUNTING BASE PLATE

The SavvyLevel external mount lid and baseplate are treated separately. The base plate is first mounted to the 'A' frame. Using 4 x M4 screws or rivets (if you want to use SavvyLevel's compass feature then you should use non-ferrous screws or aluminium rivets).

Make sure the base plate is mounted parallel to the caravan and NOT the 'A' frame. It must also be mounted level horizontally. Figures 1, 2 and 6 show correct mounting.

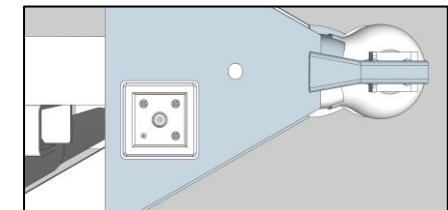

Figure 6

STEP 3 - ASSEMBLING THE LID

- Mount the Cable Gland to the Lid, making sure that the rubber washer is on the inside. Properly tighten the nylon nut.
- Separate the SavvyLevel lid from the SavvyLevel unit (the SavvyLevel lid can be discarded), remove the rubber grommet and the connectors from the black and red wire (leave enough length of wire for connection to the supply cable approx. 4 cm). Place the protection Cradle (that protects the SavvyLevel circuitry) as shown in *Figure 7*.

- C. Feed the supply cable through the Cable Gland in the Lid. Connect the positive (red) and negative (black) wires into the power supply cable from the caravan *Figure 8*.
- D. Add a small dollop of Silicone to each side of the Cradle to fix it in place (arrow marked in *Figure 7*).
- E. Carefully place the SavvyLevel into the Lid, drawing the power cable back. See *Figures 9 and 10*. Make sure that you do not mount the SavvyLevel backwards. The power wires must face towards the Cable Gland.
- F. When there is approximately between 2 – 3 cm of caravan power cable (outer insulated sheath) still in the lid, tighten the Cable Gland to create a waterproof seal.

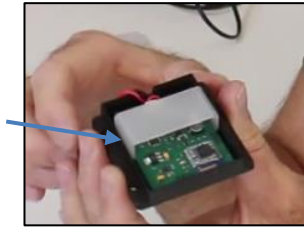

Figure 7



Figure 8



Figure 9



Figure 10

STEP 4 - WEATHER SEALING THE LID

With the SavvyLevel in place in the Lid it is considered a loose fit. You will see a small gap around the edge. Now use a silicone gun to insert silicone around the inside edges of the mount. Push the SavvyLevel to make sure it is properly in place. **USE PLENTY OF SILICONE (MORE IS BETTER THAN LESS)**. See *Figures 11, 12 and 14*.



Figure 11



Figure 12

The base is designed to ensure the silicon is forced into the correct places to guarantee a complete fully sealed fit. The silicon will also bond the Lid to the Base.

Once the silicone is applied place the Lid onto the base plate for complete seal. The lid will 'grab' the baseplate and any excess air will be injected through the baseplate central hole and excess silicone will be forced internally into the baseplate cavity. See *Figure 13 and 14*.

STEP 5 - POWERING SAVVYLEVEL

- For a weather proof seal (IP68 rated) make sure to use power cable between **3 – 6.5 mm** diameter. The cable gland used can only clamp cables within this range.
- SavvyLevel should be connected to a **separately fused** power supply from the caravan that is available on your 'A' frame. **DO NOT** tap into the tow vehicles power source (once the power hitching plug is removed from the tow vehicle, SavvyLevel will no longer have power).
- Connect power leads to a suitable 12v DC battery voltage source. The SavvyLevel device utilises a highly efficient power regulation system, it can operate from wide voltage sources ranging from 6v to 40v. SavvyLevel only draws a tiny amount of current (less than 12mA). Although this current is small it is still recommended that the supply be switchable to preserve battery charge during long periods of non-use.

CONCEPT OF OPERATION (IP68)

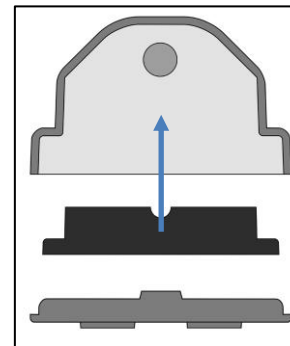

Figure 13

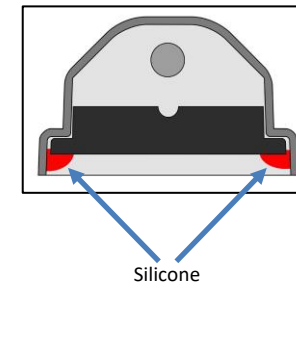
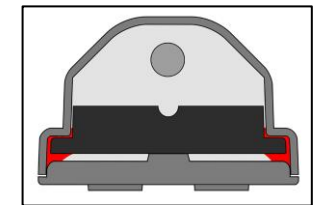

Figure 14



Pressing the Base into the Lid squeezes the silicone into the gaps.

Figure 15

Once these steps have been successfully completed and the silicone has set the SavvyLevel external mount will be rated to the IP68 standard.

Enjoy happy levelling.

