

FRD SERIES RECTANGLE INLINE MIXED FLOW CENTRIFUGAL FANS

Maximum power in a minimum of space

Limited space? No problem. Fantech's FRD Series centrifugal type exhaust/supply fans are specifically designed for large ventilation needs where space is at a premium, such as hospitals, schools, or office buildings. System balancing is easy. A simple speed adjustment equalizes all vents to compensate for hot or cold spots.

Direct-to-duct installation

The compact housing design of the FRD Series allows for installation directly within rectangular ductwork (ranging from 12"x 6" ducts to 24"x 14" ducts), without the need for large elbows or transitional sections.

FRD Series fans are simple to install; no extra materials are required. Simply mount the fan at any angle in any point in the ductwork. The motor is mounted on a hinged door – just swing the door out for easy access to the motor and wiring connections.

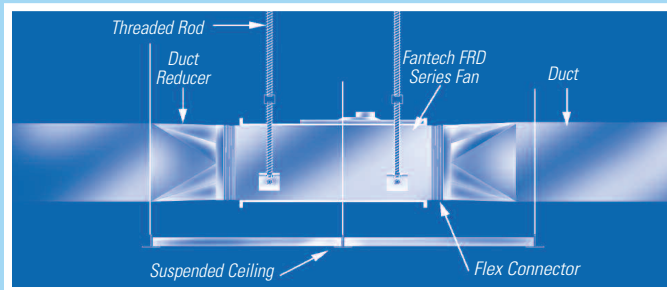

Fantech, Inc. certifies that the FRD Series shown herein is licensed to bear the AMCA Seal. The ratings shown are based on tests and procedures performed in accordance with AMCA Publication 211 and AMCA Publication 311 and comply with the requirements of the AMCA Certified Ratings Program.



**THREE
YEAR
WARRANTY**

EXTERNAL ROTOR MOTORS

All FRD Series fans utilize our unique external rotor motors. The motor's enclosed design allows the fan to operate in high moisture, lint and dust laden air. The motors are a permanent split capacitor type, with automatic reset thermal overload protection and sealed ball bearings. These features ensure long life and maintenance free operation. All motors and impellers are designed as one integral unit, allowing for excellent motor heat dissipation, even at a low RPM.

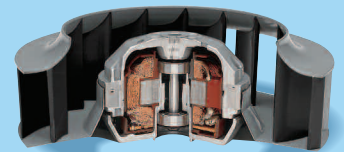

MAINTENANCE MADE EASY HERE'S WHY:

- Galvanized steel housing features baked powder coat finish
- Hinged door for service access
- External rotor motor for excellent heat dissipation even at low RPM, and built-in thermal overload protection with automatic reset.
- Suitable for airstream temperatures of up to 140° F
- UL Listed
- 100% speed controllable through voltage reduction allowing for on-demand ventilation or precision balancing of systems
- Permanently lubricated sealed ball bearings
- Airflow up to 2318 CFM
- Rectangular ductwork connections
- Terminal box with prewired electrical strip
- True backward curved impeller
- Excellent heat dissipation, ensuring long motor life
- Three-year warranty

FRD SERIES

INLINE CENTRIFUGAL FANS FOR RECTANGULAR DUCT



FRD 24-14 OPEN



FRD 24-14 CLOSED

DIMENSIONAL DATA

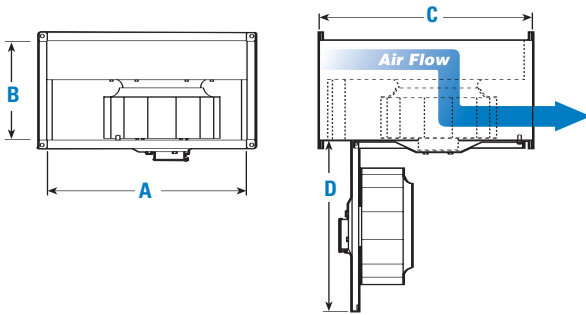

Model	A	B	C	D
FRD 12-6	11 ¹ / ₈	5 ⁷ / ₈	15 ³ / ₄	11
FRD 16-8	15 ³ / ₄	7 ³ / ₄	19 ³ / ₄	15
FRD 16-8XL	15 ³ / ₄	7 ³ / ₄	19 ³ / ₄	15
FRD 20-10	19 ⁹ / ₁₆	9 ³ / ₄	20 ⁹ / ₁₆	18
FRD 24-14	23 ⁵ / ₈	13 ³ / ₄	28 ¹ / ₂	20

All dimensions in inches.
Note: Flanges extend ¹/₈" beyond the A dimension.



Fantech, Inc. certifies that the FRD Series shown herein is licensed to bear the AMCA Seal. The ratings shown are based on tests and procedures performed in accordance with AMCA Publication 211 and AMCA Publication 311 and comply with the requirements of the AMCA Certified Ratings Program.



AIR PERFORMANCE GRAPHS

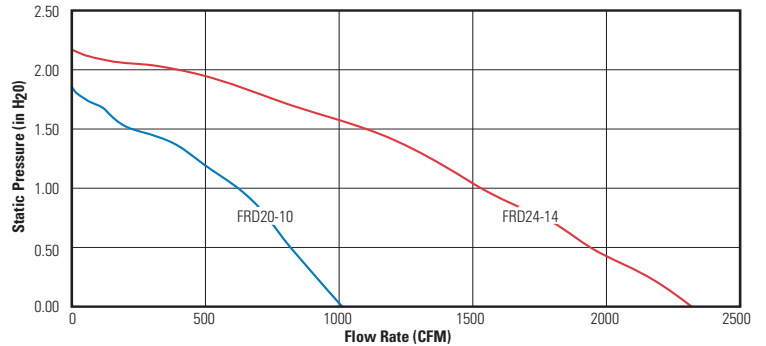
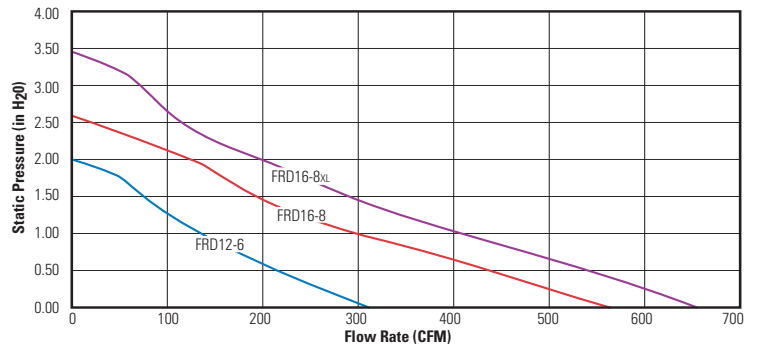

PERFORMANCE DATA (For sound performance data refer to publication FRD0607.)

Fan Model	RPM	Voltage	Rated Watts	Max. Amps	Static Pressure in Inches W.G.										Max. Ps	Duct Dim.	Sones ¹	
					0"	0.125"	0.25"	0.375"	0.5"	0.75"	1.0"	1.25"	1.5"	2.0"				2.5"
FRD 12-6	2550	115	84	0.74 ¹	309	287	262	238	214	171	133	101	75	—	—	2.01"	12" x 6"	8.0
FRD 16-8	2950	115	150	1.30 ¹	560	530	499	467	434	368	300	240	191	119	—	2.57"	16" x 8"	13.0
FRD 16-8XL	2800	115	264	2.32 ¹	658	629	599	568	535	471	406	346	290	196	114	3.44"	16" x 8"	13.1 ²
FRD 20-10	1650	115	191	1.68 ¹	1013	963	915	868	814	724	617	462	225	—	—	1.84"	20" x 10"	16.7
FRD 24-14	1650	115	597	5.18 ²	2318	2237	2149	2039	1939	1752	1527	1332	1090	377	—	2.16"	24" x 14"	18.2 ²

Performance certified is for installation type D - ducted inlet, ducted outlet. Speed (RPM) shown is nominal. Performance is based on actual speed of test. Performance ratings do not include the effects of appurtenances (accessories).

¹ The sound ratings shown are loudness values in fan sones at 5ft. (1.5m) in hemispherical free field calculated per AMCA Standard 301. Values shown are for installation Type D: ducted inlet fan sone levels. Ratings do not include the effect of duct end correction. Sone values shown was calculated at 0.5". (static pressure in inches W.G.).

² Sone value shown was calculated at 0.75" (static pressure in inches W.G.).

¹ Recommended speed control rating 5A.

² Recommended speed control rating 10A.



United States 1712 Northgate Blvd. • Sarasota, FL. 34234 • 1.800.747.1762 • www.fantech.net
Canada 50 Kanalfakt Way • Bouctouche, NB E4S 3M5 • 1.800.565.3548 • www.fantech.ca

Item #: 450398
Rev Date: 071107

Fantech, reserves the right to modify, at any time and without notice, any or all of its products' features, designs, components and specifications to maintain their technological leadership position.