

TPX-100-E

TOWBARLESS AIRCRAFT TRACTOR



DESCRIPTION

The TPX-100-E is an electric towbarless tractor designed for push back of most commuters, and single aisle aircrafts up to 100 tons, from SAAB 2000 to BOEING B757 (100 tons maxi). * Its unique AC/DC technology in this range of tractor increases driving comfort & lifetime and allows to get more reliability and to reduce operating costs.

The cradle system is designed to fit all NLG, included inclined one. It includes the over torque alerting device. The automatic control of loading/unloading cycle allows fail safe operations. Provided with a comfortable ergonomic cabin, the TPX-100-E offers a high level of maneuverability combined with an excellent visibility. Thank to its heavy-duty design the TPX-100 E is a very reliable tractor.

* Consult us for details.

STANDARD FEATURES

- **Motors** : 2 asynchronous electrical 11 kW motors
- **Inverters** : Power adjusted by means of 2 80 V AC controllers.
- **DBP : Driveline capability** : up to 3,900 daN (8,730 lbs) according to aircraft family.
- **Maximum NLG load** : 10,000 daN (22,000 lbs)
- **Maximum NLG width** : 950 mm (37.4")
- **Maximum speed** : 15 kph (9.4 mph)
- **Brakes (service)** : Current regeneration on driving wheels, dry discs on steering wheels.
- **Brakes (parking)** : Integrated in wheel reducers, operating by lack of current (failsafe system).
- **Steering** : Hydrostatic, operating on rear bogie.
- **Tires** : 180/70-R8 on front, 6.00R9 on rear.
- **Security** : Draw Bar Pull controller, emergency stop button, overtorque landing gear alerting device.
- **Hydraulic tank** : 45 liters (12 US Gal)
- **Emergency equipment**: Hand pump to release aircraft and remove the tractor.
- **Paint** : White – RAL 9016
- **Cab** : With doors and suspended seat

ELECTRICAL EQUIPMENTS

24 VDC electrical system equipped with following equipment :

- Batteries (options) 80 V, 775 AH.
- Hourmeter, discharge indicator.
- Parking brake & cradle state light.
- Overtorque indication
- Cycles managed by PLC
- Lazer Guide

Tolerances of mentioned data : +/- 5 %
Specifications may be altered as a constant effort to improve performances.
Some views may show optional equipments.

TPX-100-E



DIMENSIONS AND WEIGHT :

- Gross weight 7,850 kg (17,300 lbs)
- Length 6 690 mm (263.4")
- Overall width 2 500 mm (98.4") (*)
- Height 1 850 mm (72.8")
- Turning radius 7 655 mm (301,4")

* With external front wheels removed : 2 430 mm (95.7"), for 40' container shipment

OPTIONS AVAILABLE

- Heater and defroster
- Special paint

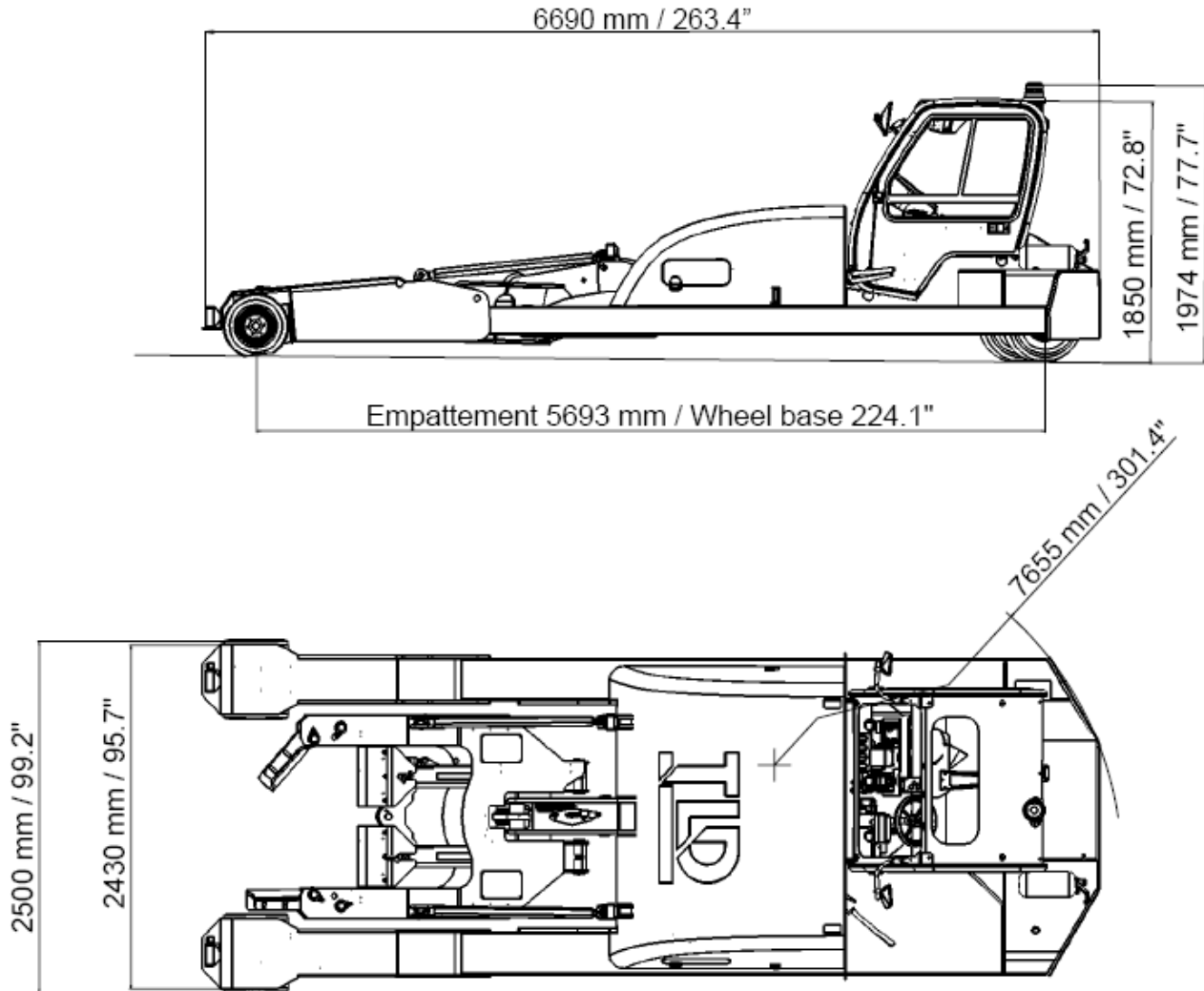

Revised on 15/03/2010 by CB

TLD GSE sales group and headquarters :

- **Asia**
TLD-ASIA, Hong Kong
Tel : + 852 (2)692-2181 Fax : + 852 (2)691-2604
- **Europe, Africa, Middle East, India**
TLD-EUROPE, France
Tel + 33 (0)1 45 60 71 40 Fax + 33 (0)1 45 60 57 00
- **North & South America, Australia & New Zealand, Japan**
TLD-AMERICA, USA
Tel : + 1 (860) 602-3400 Fax : + 1 (860) 688-7895

Contact us on our Web site : www.tld-gse.com

TUST028K TPX-100-E A.doc

Tolerances of mentioned data : +/- 5 %
Specifications may be altered as a constant effort to improve performances.
Some views may show optional equipments