

SELF PROPELLED PASSENGER STEP model EDU-WIDE



Easy to operate, easy to maintain, the Self-propelled Universal Passenger Step, model EDU-WIDE, has been designed for embarking and disembarking passengers on all aircraft with sill heights ranging from 2.40m to 5.80m (front door of B737 to rear door of A-340) and can be provided with open or closed cabin and optional canopy. The unit incorporates hydrostatic transmission, diesel engine and hydraulic steering in a slide open engine compartment.

Overall Dimensions and Weight:

Length (retracted).....	7.78 m.
Width.....	2.97 m.
Height (retracted).....	3.65 m.
Weight (without cab).....	7.200 Kgs.

Performance:

Min. height.....	2.40 m
Max. Height.....	5.80 m
Step width (upper section).....	1.66 m.
Step width (lower section).....	1.50 m.
Access platform width.....	2.86 m.
Access platform length.....	2.30 m.
Maximum speed.....	25 km/h.
Inner turning radius.....	4.00 m

Brief Technical Specifications

- Universal use, from B-737 to B-747, A-340
- Water cooled, 4 cylinder Perkins diesel engine, model 404 D22, 36,9 kW (Stage IIIA).
- The engine is longitudinally supported by 4 hydraulic mountings in a compartment which slides open for excellent accessibility
- This open-out compartment houses the diesel engine, the main hydraulic automotive, anti-stall pump for traction and gear pump for service, the fuel and hydraulic tanks and the batteries and battery cut-off switch.
- Extra-wide stairway for two passengers with hand luggage (1,5 m. mobile flight)
- Top platform with swivel floor of 10° to automatically align with the contour of the aircraft fuselage (swivels on rollers)
- Special articulated side panels allow unobstructed opening/closing of aircraft door and virtually follow (both WB and NB) the curvature of the a/c fuselage without exerting any force and thereby avoiding damage to the aircraft.
- All areas coming into contact with the aircraft are white rubber protected to prevent staining fuselage.
- Brakes: Independent brake circuits:
 - a) Hydraulic drum brakes on the front wheels.
 - b) Adjustable hydrostatic brake on the rear axle hydraulic motors.

A wide range of options is available on request:

- Enclosed or open driver's cabin with or without heating
- Fully enclosed canopy with electrically powered concertina interface which adapts perfectly to aircraft fuselage
- Air cooled, 4 cylinder Deutz diesel engine, model D2011L04i, 37 kW (COM 3A)
- Powershift System: Protection system enabling driver to go from forward to reverse or vice-versa at full speed without damaging transmission.
- Controls at top access platform
- Aluminum non slip tread steps and platforms (Alusuisse or similar) for

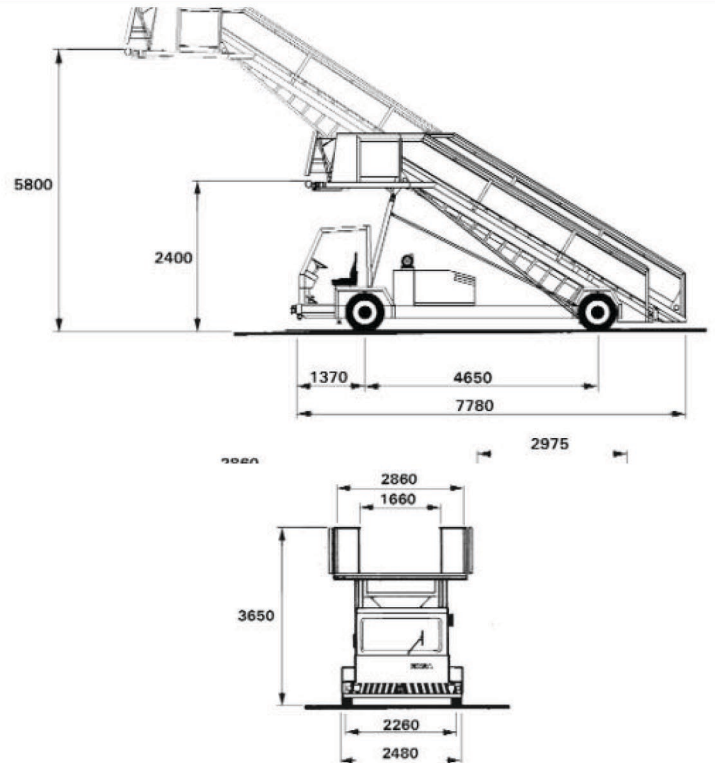

- c) Automatic pressure failure negative parking brake on the rear axle. Activated automatically when in neutral or when the engine is stopped.
- Rear drive axle with high torque hub motors on each wheel
- Hydrostatic transmission
- Front steering axle
- Hydraulic steering
- 4 hydraulic stabilizers
- Protection belt at bottom staircase to inhibit un-authorized access, with driving interlock.
- Physical barrier for protection at the top platform
- Check valves on main telescopic cylinder and stabilizers
- Automatic stair-locks
- Hydraulic oil tank capacity of 100 litres
- Fuel tank capacity of 128 litres
- Emergency manual pump for retracting stabilizers and releasing brakes and lowering mobile flight.
- 12 V DC electric system with 2 independent 12 V batteries (stair lights and starting)
- Front and rear pneumatic tyres 215/75 R17,5"
- Steps LED lights
- **Compliance with EN-12312-3**

snow, water evacuation

- Wide cab for driver's post (2/3 persons)
- Winter kit for low temperatures up to -25°C with 24 V electric system
- System to limit speed to 6 Km/h with mobile flight extended
- Ultrasonic proximity sensor
- Rotating beacon
- Steps numbered for height sill reference
- Spotlights mounted at customer's choice
- Compliance with AHM 913
 - Anticollision system
 - Docking system
 - Smart bumper

