



MSA

OPERATING SPEED	0,1 - 1 m/s (related to actuator form)
OPERATING FREQUENCY	Mechanical 60 cycles/min; Electrical 15 cycle/min
INSULATION RESISTANCE	≥100MΩ (500 VDC)
CONTACT RESISTANCE	< 100mΩ (initial value)
TEST VOLTAGE (each terminal same polarity)	AC1000V, 50/60HZ, 1MIN
TEST VOLTAGE (each terminal and non current carrying metal parts)	AC1500V, 50/60HZ, 1MIN
TEMPERATURE GRADE	-25 °C ≤ T ≤ 125 °C
VIBRATION RESISTANCE	10-55Hz, 1.5mm, double amplitude
LIFE EXPECTANCY	Mechanical ≥ 10 Mio cycles Electrical ≥ 50 k cycles



DRAWING

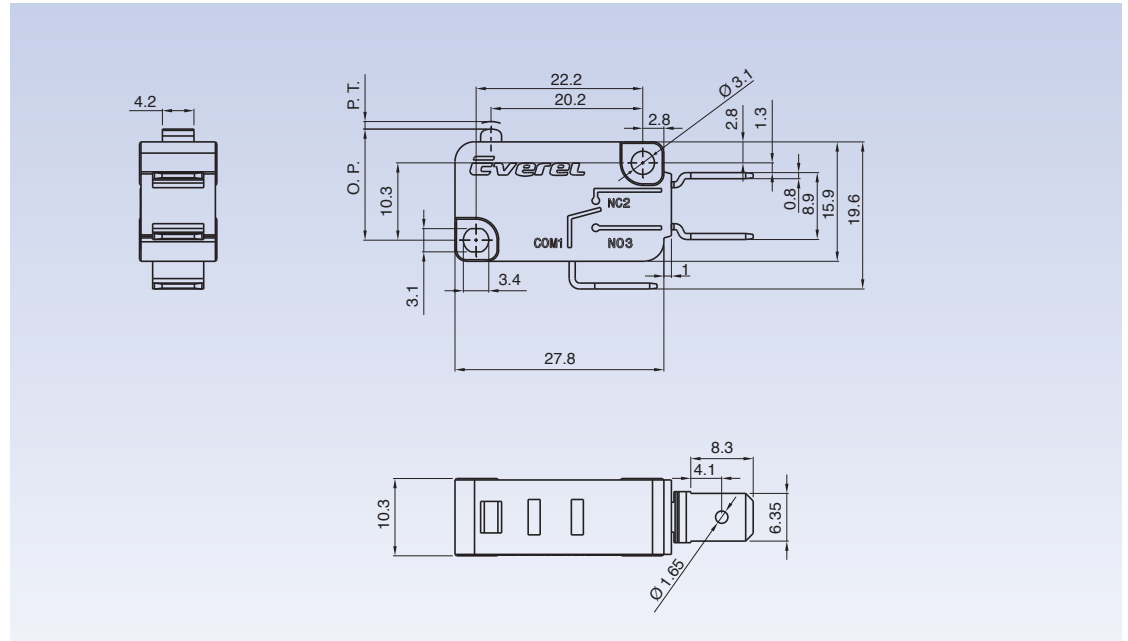

- M
- S
- A
- ?
- ?
- ?
- ?
- ?
- ?
- ?
- ?

TEMPERATURE GRADE

T
25T125

ELECTRICAL RATING

16
16 (4) A / 250 VAC - 5E4
μ disconnection
EN 61058

16 A - 120/250 VAC
1/2 HP - 120/250 VAC
UL 1054

26
26 (10) A / 250 VAC - 5E4
μ disconnection
EN 61058

TERMINAL STYLE

C1
6.3 X 0.8

CIRCUIT CODE

Z SPDT

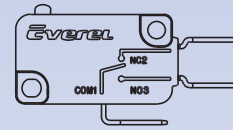

P SPST NO

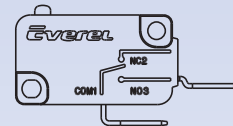

C SPST NC

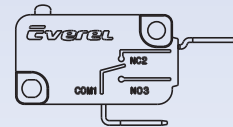

OPERATING FORCE

200
Electrical Rating 16
200 gf 1,96N

300
Electrical Rating 26
300 gf 2,94N

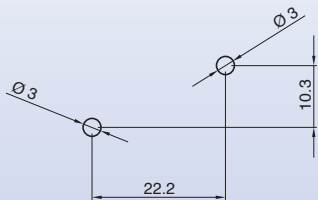

M	S	A	TEMP. GRADE	ELECTRICAL RATING	TERMINAL STYLE	CIRCUIT CODE	OPERATING FORCE	LEVER TYPE

ACCESSORIES: LEVERS AVAILABLE

000

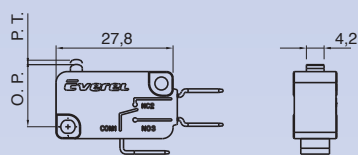

PARAMETERS

OF Max		RF Min		PT Max	OT Min	DT Max	OP
(N)	(gf)	(N)	(gf)	(mm)	(mm)	(mm)	(mm)
1.96	200	0.49	50	1.6	0.8	0.4	14.7

A01

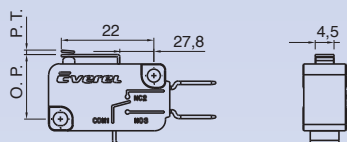

PARAMETERS

OF Max		RF Min		PT Max	OT Min	DT Max	OP
(N)	(gf)	(N)	(gf)	(mm)	(mm)	(mm)	(mm)
1.96	200	0.49	50	1.6	0.8	0.4	15.3

A02

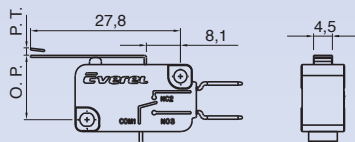

PARAMETERS

OF Max		RF Min		PT Max	OT Min	DT Max	OP
(N)	(gf)	(N)	(gf)	(mm)	(mm)	(mm)	(mm)
1.18	120	0.20	20	3.2	1.3	1.2	15.3

A04

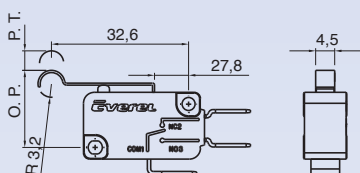

PARAMETERS

OF Max		RF Min		PT Max	OT Min	DT Max	OP
(N)	(gf)	(N)	(gf)	(mm)	(mm)	(mm)	(mm)
1.18	120	0.20	20	3.2	1.3	1.2	18.3

A05

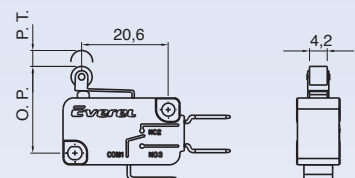

PARAMETERS

OF Max		RF Min		PT Max	OT Min	DT Max	OP
(N)	(gf)	(N)	(gf)	(mm)	(mm)	(mm)	(mm)
2.35	240	0.39	40	1.6	0.8	0.4	20.6

A06

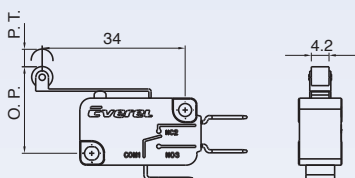

PARAMETERS

OF Max		RF Min		PT Max	OT Min	DT Max	OP
(N)	(gf)	(N)	(gf)	(mm)	(mm)	(mm)	(mm)
1.18	120	0.20	20	3.2	1.3	1.2	20.6

OF = Operating Force
RF = Related Force
PT = Pre Travel
OT = Over Travel
DT = Different Travel
OP = Operating Position