

Towable Passenger Stair

ST 320



TOWABLE STAIR (MOTORIZED TOWING SYSTEM OPTIONAL)

Operative range mm. 3.200 – 3.700
Ramp width mm. 1200

*For technical and operational features
ask for Specification n° 1516*

AVIOGEI
Airport Equipment Srl

VIA CAMPOLEONE TENUTA N° 13 - 04010 CAMPOLEONE, APRILIA (LT) ITALIA

TEL +39 06 92 78 251 r. a. FAX +39 06 927 84 54

aviogei@aviogei.it

<http://www.aviogei.it>



MAIN TECHNICAL DATA

Towable passenger stair ST 320

Maximum towing speed	Km/h	30			
Stabilizer	n°	4	Steering System	Front	Fifth wheel
Ramp			Wheels	super elastic tyre	Size 4.00-8
Width	mm	1.200	Brake	Acting on front wheels	When tow-bar is up
Max. operational height	mm	3.700	Manual pump		For operating the ramp, the stabilizers.
Min. operational height	mm	3.200			
Steps					
N		17			
Height	mm	195			
Tread	mm	265			
Platform		1700 X 1000			
In conformity with IATA regulations AHM 910 – AHM 913 – AHM 915 – AHM 920A			In compliance with 2006/42 CE regulation ISO 9001 – Vision 2008		

OPTIONALS	SHIPPING DATA		
Motorized wheel leaded by joystick to allow an easy approach to the aircraft	Length	mm	6.830
Electro pump	Height	mm	3.500
Electrical system 12 Vcc for lighting ramp	Width	mm	2.410
Handrails in stainless steel	Weight	kg	3.100

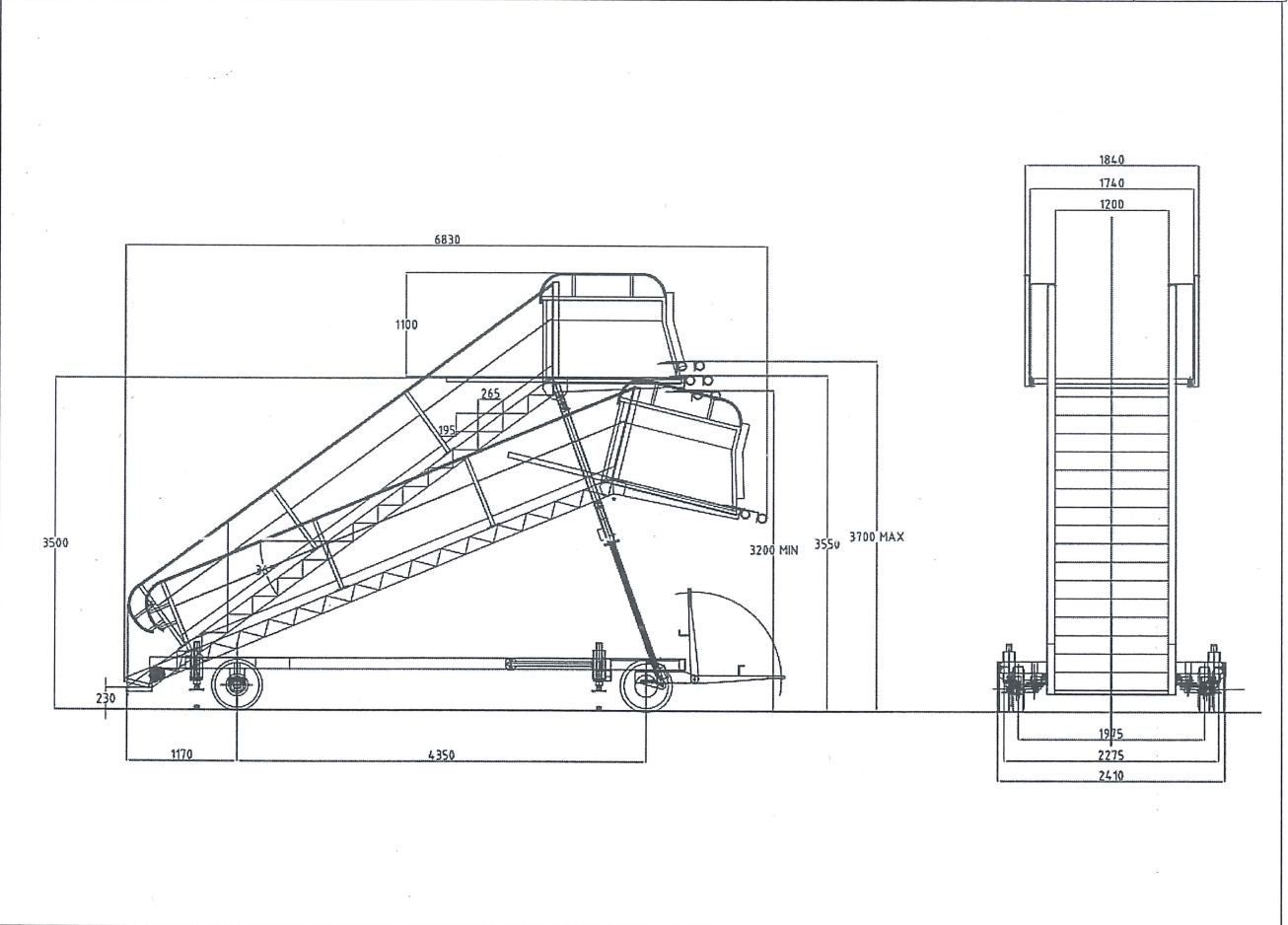

AVIOGEI

Short Tech. Spec. 1516

AVIOGEI

Aviopei reserves the right to change details as a result of product improvement