



SENSEI™

THE NEXT GENERATION IN TANKLESS WATER HEATING

SENSEI™

Major Time and Energy Savings

With an enhanced combustion design, the Rinnai SENSEI Tankless Water Heater provides a better experience for both users and installers. Like all Rinnai Tankless Water Heaters, it's also vertically integrated. That means all key components are manufactured by Rinnai — to ensure Rinnai quality.



THE ADVANTAGES



**EASY
INSTALLATION**



**OPERATIONAL
PERFORMANCE**



SERVICEABILITY

Condensing Technology for Colder Climates

The Rinnai SENSEI offers freeze protection down to **-4° F** (for outdoor units) or **-22° F** (for indoor units) through:

- **NEW** integrated check valve that prevents backflow from outside cold air
- **NEW** Fiber Mesh Premix Burner
- Integrated logic to temporarily activate the unit in extreme cold climates



Look Inside

All components work together harmoniously to provide the best combustion performance possible.

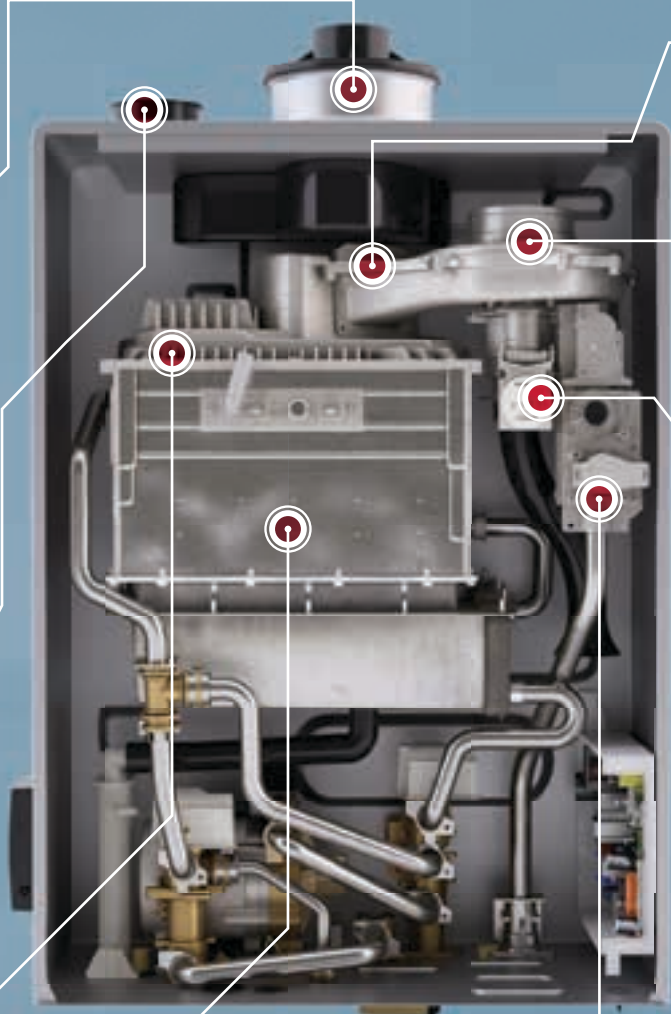

NEW Concentric Vent or 2-Inch Exhaust*

- Allows for easy use of concentric 2"/4" or 3"/5" direct vent or exhaust in 2-pipe or room-air configurations

NEW 2-Inch Intake Vent Connections

- Allows for maximum flexibility with the use of 2" PVC/CPVC/PP on vent runs up to 65 feet

NEW Fiber Mesh Premix Burner*

- Provides even flame distribution for optimal performance for any demand

NEW Primary Stainless Steel Heat Exchanger*

- R-evolution™**
- Resists the corrosive nature of the condensate, which occurs early in the high-efficiency combustion process

NEW Integrated Check Valve

- Located between the turbo fan and combustion chamber
- Prevents cold air from entering the venting system and backflow of exhaust in common vent applications

NEW Turbo Fan*

- Enables longer vent runs and flexible vent options
- Up to 65 feet vent runs with 2"/4" concentric and 2" PVC/CPVC/PP
- Up to 150 feet vent runs with 3"/5" concentric and 3" PVC/CPVC/PP

NEW Switching Venturi*

- Provides consistent mixture of air and gas to burner for low turn-down ratios
- Self-compensates in areas with low or fluctuating gas pressures

NEW Zero Governor Gas Valve*

- Optimizes combustion performance by consistently delivering gas and air mixture

*Manufactured by Rinnai

Most Flexible Venting in the Industry

The Rinnai® Sensei™ can go in an old condensing vent system for replacement if needed, but new installs can use smaller, lighter, less expensive concentric venting.

- 14 possible vent configurations
- 9 compatible vent manufacturers*

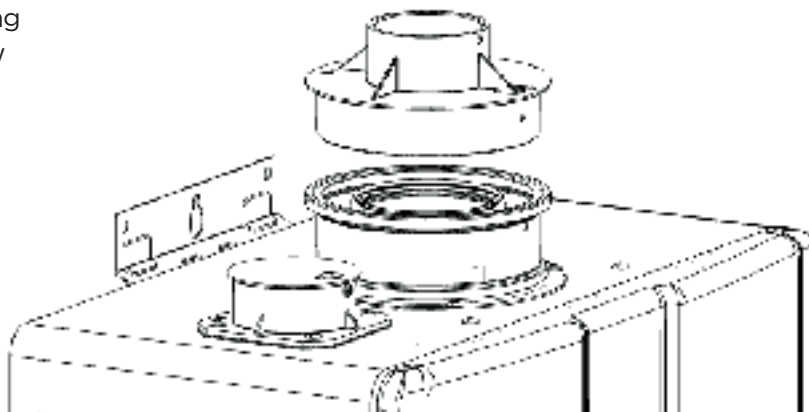

2" adaptor ring and cap let you use 3"x 5" concentric venting or 2" twin pipe venting

*Includes PVC

Now Including 2" Venting Options

CONCENTRIC		
DIAMETER	EQUIVALENT LENGTH	TERMINATION
3" X 5"	150' (46 m)	VERTICAL OR HORIZONTAL
2" X 4" (NEW)	65' (20 m)	VERTICAL OR HORIZONTAL

- Unit requires only a single penetration through the wall, reducing install time and costs
- Simple positive-fit components offer a secure connection
- Joint seals expand and contract with weather to prevent damage
- Assembly and adjustment are easy

TWIN PIPE AND ROOM AIR			
DIAMETER	MATERIAL	EQUIVALENT LENGTH	TERMINATION
3"	PP, PVC, CPVC	150' (46 m)	VERTICAL OR HORIZONTAL
2" (NEW)	PP, PVC, CPVC	65' (20 m)	VERTICAL OR HORIZONTAL

Example Vent Configurations

CONCENTRIC

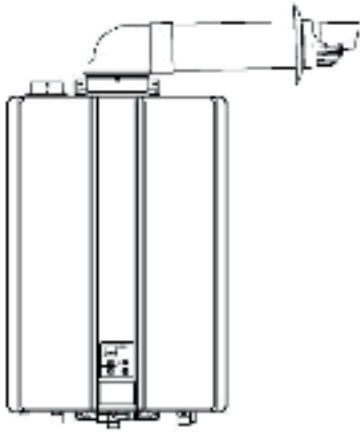

2" x 4" horizontal wall termination configuration

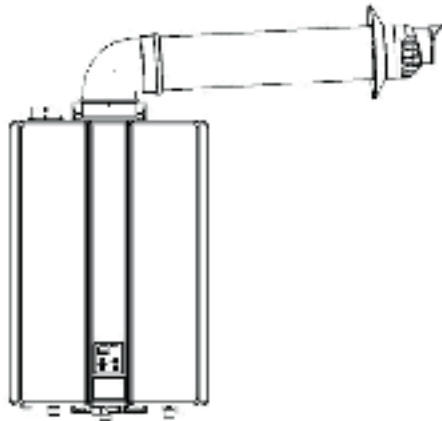

3" x 5" horizontal wall termination configuration

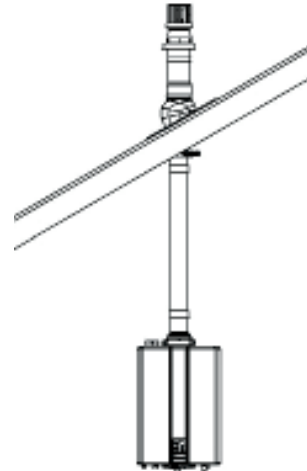

2" x 4" or 3" x 5" vertical roof termination configuration

TWIN PIPE

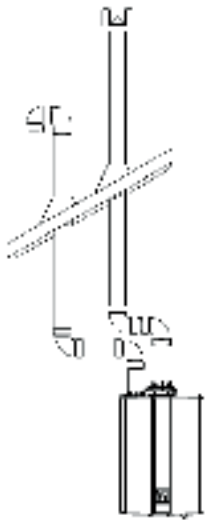

Vertical termination direct vent configuration

ROOM AIR



Vertical termination room air configuration

ELBOWS OR TEES

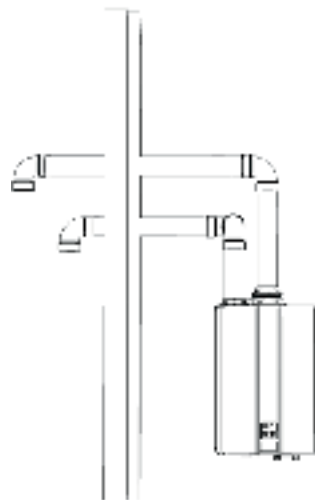

Elbow or tee side wall termination direct vent configuration

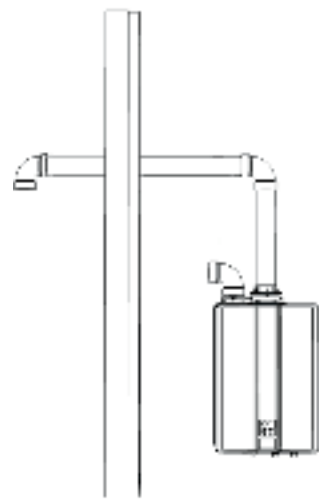

Elbow or tee side wall termination room air configuration

Easy Installation and Serviceability

Adjustable Mounting Plate

A versatile design lets you handle variable installations due to varying stud alignment.

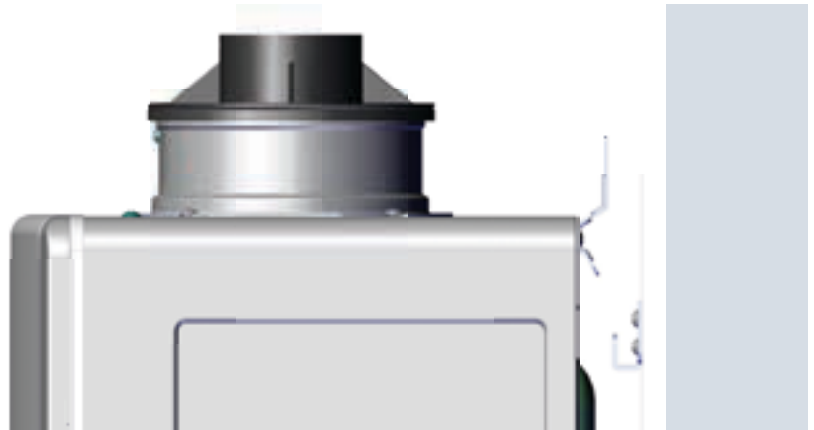

Quick & Easy Gas Conversion

An inexpensive conversion kit requires just three simple steps.

- 1 Remove 3 screws
- 2 Change the orifice and parameter
- 3 Apply new data plate

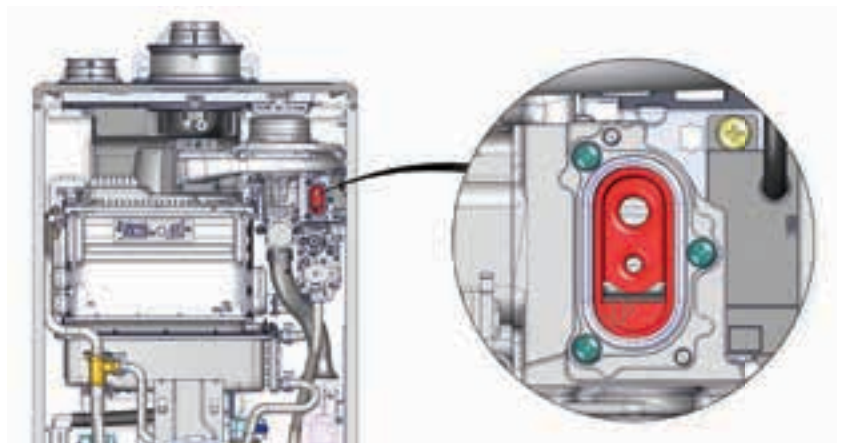

Convenient Isolation Valves + PRV

The pressure relief valve assembly can rotate 360° to accommodate the installation of isolation valves in any application.

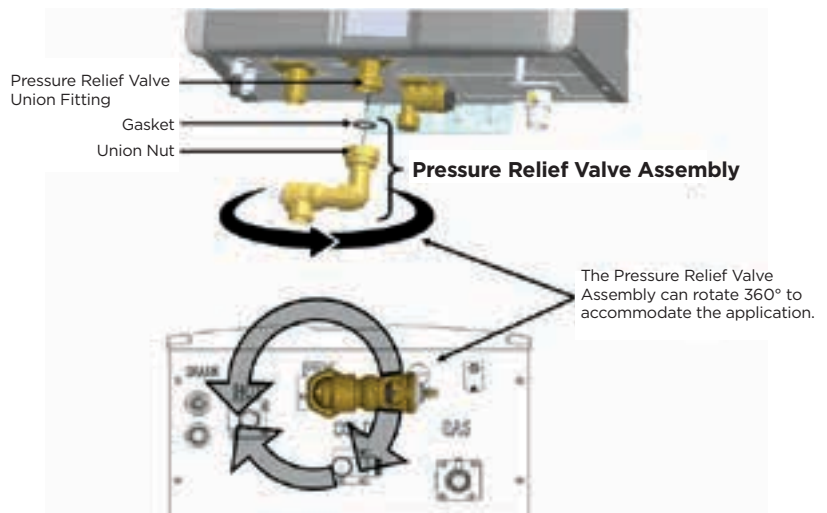

Easy Parameter Adjustments

- Installation is more efficient with easily accessible control panel
- Controls are integrated on internal and external models
- A parameter adjustment can be made for greater hot water flow (up to 11 GPM) in areas with a low delta T
- Simply use the arrows on the controller to select a setting number



MODEL CHART AND SPECIFICATIONS

SUPER-HIGH-EFFICIENCY (CONDENSING) TANKLESS WATER HEATERS

SE+ SERIES



FEATURING
ThermaCirc360



FEATURING
ThermaCirc360



FEATURING
ThermaCirc360



FEATURING
ThermaCirc360

MODEL	RUR199i	RUR199e	RUR160i	RUR160e
DIMENSIONS - W, H, D INCHES (MM)	18.5 X 26.4 X 11.5 (470 X 670 X 290)	18.5 X 26.4 X 11.5 (470 X 670 X 290)	18.5 X 26.4 X 11.5 (470 X 670 X 290)	18.5 X 26.4 X 11.5 (470 X 670 X 290)
WEIGHT (LBS / KG)	73 / 33	73 / 33	71 / 32	71 / 32
INSTALLATION TYPE	INDOOR	OUTDOOR	INDOOR	OUTDOOR
MIN./MAX. BTU	15,000/199,000	15,000/199,000	15,000/160,000	15,000/160,000
TEMP. RANGE RESIDENTIAL	98° F - 140° F / 37° C - 60° C	98° F - 140° F / 37° C - 60° C	98° F - 140° F / 37° C - 60° C	98° F - 140° F / 37° C - 60° C
TEMP. RANGE COMMERCIAL	98° F - 140° F / 37° C - 60° C	98° F - 140° F / 37° C - 60° C	98° F - 140° F / 37° C - 60° C	98° F - 140° F / 37° C - 60° C
MINIMUM ACTIVATION RATE	0.4 GPM (1.5 L/MIN)	0.4 GPM (1.5 L/MIN)	0.4 GPM (1.5 L/MIN)	0.4 GPM (1.5 L/MIN)
FLOW RATE (70°/50° TEMP. RISE)	5.4 / 7.6	5.4 / 7.6	4.3 / 6.1	4.3 / 6.1
HOT WATER FLOW RATE RANGE	0.26 - 9.8 GPM (1.0 - 37 L/MIN)	0.26 - 9.8 GPM (1.0 - 37 L/MIN)	0.26 - 8.0 GPM (1.0 - 30 L/MIN)	0.26 - 8.0 GPM (1.0 - 30 L/MIN)
CONTROLLER (STANDARD)	INTEGRATED			
CONTROLLERS (OPTIONAL)	MC-91-2US, REQUIRED FOR RECIRCULATION: MC-195T-US OR CONTROL-RTM WI-FI MODULE			
CERTIFICATIONS	AHRI, CSA, ENERGY STAR®			
WARRANTY (RESIDENTIAL)**	LIMITED 15-YEAR ON HEAT EXCHANGER, 5-YEAR ON PARTS, 1-YEAR ON LABOR			
WARRANTY (COMMERCIAL)**	LIMITED 8-YEAR ON HEAT EXCHANGER, 5-YEAR ON PARTS, 1-YEAR ON LABOR	LIMITED 8-YEAR ON HEAT EXCHANGER, 5-YEAR ON PARTS, 1-YEAR ON LABOR	LIMITED 8-YEAR ON HEAT EXCHANGER, 5-YEAR ON PARTS, 1-YEAR ON LABOR	LIMITED 8-YEAR ON HEAT EXCHANGER, 5-YEAR ON PARTS, 1-YEAR ON LABOR
MOBILE HOME CERTIFIED	YES	YES	YES	YES
VALVES SHIPPED IN BOX	YES	YES	YES	YES
HIGH ALTITUDE APPROVED	UP TO 10,200 FT. (3,109 M)	UP TO 10,200 FT. (3,109 M)	UP TO 10,200 FT. (3,109 M)	UP TO 10,200 FT. (3,109 M)
VENTING OPTIONS	CONCENTRIC OR PVC/CPVC/PP	N/A	CONCENTRIC OR PVC/CPVC/PP	N/A
ULTRA LOW NOX	YES	YES	YES	YES
TANKLESS RACK SYSTEM™ (TRS/TRW) COMPATIBLE	YES	YES	YES	YES
1/2" GAS LINE COMPATIBLE†	YES	YES	YES	YES
WI-FI READY	YES	YES	YES	YES

*To achieve temperatures over 140° F (60° C), consult the Operation and Installation Manual.

**For complete information and details regarding Rinnai's warranty, visit rinnai.us.

†For complete information on gas sizing for Rinnai Tankless Water Heaters, consult the Operation and Installation Manual.



RU199i	RU199e	RU180i	RU180e
18.5 X 26.4 X 11.5 (470 X 670 X 290)	18.5 X 26.4 X 11.5 (470 X 670 X 290)	18.5 X 26.4 X 11.5 (470 X 670 X 290)	18.5 X 26.4 X 11.5 (470 X 670 X 290)
64 / 29	62 / 28	64 / 29	62 / 28
INDOOR	OUTDOOR	INDOOR	OUTDOOR
15,000/199,000	15,000/199,000	15,000/180,000	15,000/180,000
98° F - 140° F / 37° C - 60° C*	98° F - 140° F / 37° C - 60° C*	98° F - 140° F / 37° C - 60° C*	98° F - 140° F / 37° C - 60° C*
98° F - 185° F / 37° C - 85° C*	98° F - 185° F / 37° C - 85° C*	98° F - 185° F / 37° C - 85° C*	98° F - 185° F / 37° C - 85° C*
0.4 GPM (1.5 L/MIN)	0.4 GPM (1.5 L/MIN)	0.4 GPM (1.5 L/MIN)	0.4 GPM (1.5 L/MIN)
5.4 / 7.6	5.4 / 7.6	4.9 / 6.9	4.9 / 6.9
0.26 - 9.8 GPM (1.0 - 37 L/MIN)	0.26 - 9.8 GPM (1.0 - 37 L/MIN)	0.26 - 9.0 GPM (1.0 - 34 L/MIN)	0.26 - 9.0 GPM (1.0 - 34 L/MIN)
INTEGRATED			
MC-195T-US, MC-91-2US, MCC-91-2US			
AHRI, CSA, ENERGY STAR®			
LIMITED 15-YEAR ON HEAT EXCHANGER, 5-YEAR ON PARTS, 1-YEAR ON LABOR			
LIMITED 8-YEAR ON HEAT EXCHANGER, 5-YEAR ON PARTS, 1-YEAR ON LABOR	LIMITED 8-YEAR ON HEAT EXCHANGER, 5-YEAR ON PARTS, 1-YEAR ON LABOR	LIMITED 8-YEAR ON HEAT EXCHANGER, 5-YEAR ON PARTS, 1-YEAR ON LABOR	LIMITED 8-YEAR ON HEAT EXCHANGER, 5-YEAR ON PARTS, 1-YEAR ON LABOR
YES	YES	YES	YES
YES	YES	YES	YES
UP TO 10,200 FT. (3,109 M)	UP TO 10,200 FT. (3,109 M)	UP TO 10,200 FT. (3,109 M)	UP TO 10,200 FT. (3,109 M)
CONCENTRIC OR PVC/CPVC/PP	N/A	CONCENTRIC OR PVC/CPVC/PP	N/A
YES	YES	YES	YES
YES	YES	YES	YES
YES	YES	YES	YES
YES	YES	YES	YES

MODEL CHART AND SPECIFICATIONS

SUPER-HIGH-EFFICIENCY (CONDENSING) TANKLESS WATER HEATERS

SE+ SERIES



MODEL	RU160i	RU160e	RU130i	RU130e
DIMENSIONS - W, H, D INCHES (MM)	18.5 X 26.4 X 11.5 (470 X 670 X 290)	18.5 X 26.4 X 11.5 (470 X 670 X 290)	18.5 X 26.4 X 11.5 (470 X 670 X 290)	18.5 X 26.4 X 11.5 (470 X 670 X 290)
WEIGHT (LBS / KG)	64 / 29	62 / 28	64 / 29	62 / 28
INSTALLATION TYPE	INDOOR	OUTDOOR	INDOOR	OUTDOOR
MIN./MAX. BTU	15,000/160,000	15,000/160,000	15,000/130,000	15,000/130,000
TEMP. RANGE RESIDENTIAL*	98° F - 140° F / 37° C - 60° C	98° F - 140° F / 37° C - 60° C	98° F - 140° F / 37° C - 60° C	98° F - 140° F / 37° C - 60° C
TEMP. RANGE COMMERCIAL**	98° F - 185° F / 37° C - 85° C	98° F - 185° F / 37° C - 85° C	98° F - 185° F / 37° C - 85° C	98° F - 185° F / 37° C - 85° C
MIN. ACTIVATION RATE	0.4 GPM (1.5 L/MIN)	0.4 GPM (1.5 L/MIN)	0.4 GPM (1.5 L/MIN)	0.4 GPM (1.5 L/MIN)
FLOW RATE (70°/50° TEMP. RISE)	4.3 / 6.1	4.3 / 6.1	3.5 / 4.9	3.5 / 4.9
HOT WATER FLOW RATE RANGE	0.26 - 8.0 GPM (1.0 - 30 L/MIN)	0.26 - 8.0 GPM (1.0 - 30 L/MIN)	0.26 - 6.6 GPM (1.0 - 24 L/MIN)	0.26 - 6.6 GPM (1.0 - 24 L/MIN)
CONTROLLER (STANDARD)	INTEGRATED	INTEGRATED	INTEGRATED	INTEGRATED
CONTROLLERS (OPTIONAL)	MC-195T-US, MC-91-2US, MCC-91-2US	MC-195T-US, MC-91-2US, MCC-91-2US	MC-195T-US, MC-91-2US, MCC-91-2US	MC-195T-US, MC-91-2US, MCC-91-2US
CERTIFICATIONS	AHRI, CSA, ENERGY STAR®	AHRI, CSA, ENERGY STAR®	AHRI, CSA, ENERGY STAR®	AHRI, CSA, ENERGY STAR®
WARRANTY (RESIDENTIAL)**	LIMITED 15-YEAR ON HEAT EXCHANGER, 5-YEAR ON PARTS, 1-YEAR ON LABOR	LIMITED 15-YEAR ON HEAT EXCHANGER, 5-YEAR ON PARTS, 1-YEAR ON LABOR	LIMITED 15-YEAR ON HEAT EXCHANGER, 5-YEAR ON PARTS, 1-YEAR ON LABOR	LIMITED 15-YEAR ON HEAT EXCHANGER, 5-YEAR ON PARTS, 1-YEAR ON LABOR
WARRANTY (COMMERCIAL)**	LIMITED 8-YEAR ON HEAT EXCHANGER, 5-YEAR ON PARTS, 1-YEAR ON LABOR	LIMITED 8-YEAR ON HEAT EXCHANGER, 5-YEAR ON PARTS, 1-YEAR ON LABOR	LIMITED 8-YEAR ON HEAT EXCHANGER, 5-YEAR ON PARTS, 1-YEAR ON LABOR	LIMITED 8-YEAR ON HEAT EXCHANGER, 5-YEAR ON PARTS, 1-YEAR ON LABOR
MOBILE HOME CERTIFIED	YES	YES	YES	YES
VALVES SHIPPED IN BOX	YES	YES	YES	YES
HIGH ALTITUDE APPROVED	UP TO 10,200 FT. (3,109 M)	UP TO 10,200 FT. (3,109 M)	UP TO 10,200 FT. (3,109 M)	UP TO 10,200 FT. (3,109 M)
VENTING OPTIONS	CONCENTRIC OR PVC/CPVC/PP	N/A	CONCENTRIC OR PVC/CPVC/PP	N/A
ULTRA LOW NOX	YES	YES	YES	YES
TANKLESS RACK SYSTEM™ (TRS/TRW) COMPATIBLE	YES	YES	YES	YES
1/2" GAS LINE COMPATIBLE††	YES	YES	YES	YES
WI-FI READY	YES	YES	YES	YES

*To achieve temperatures over 140° F (60° C), consult the Operation and Installation Manual.

†To achieve temperatures up to 185° F (85° C), consult the Operation and Installation Manual.

**For complete information and details regarding Rinnai's warranty, visit rinnai.us.

††For complete information on gas sizing for Rinnai Tankless Water Heaters, consult the Operation and Installation Manual.

COMMERCIAL SERIES



CU199i	CU199e	CU160i	CU160e
18.5 X 26.4 X 11.5 (470 X 670 X 290)	18.5 X 26.4 X 11.5 (470 X 670 X 290)	18.5 X 26.4 X 11.5 (470 X 670 X 290)	18.5 X 26.4 X 11.5 (470 X 670 X 290)
64 / 29	64 / 29	62 / 28	62 / 28
INDOOR	OUTDOOR	INDOOR	OUTDOOR
15,000/199,000	15,000/199,000	15,000/160,000	15,000/160,000
N/A	N/A	N/A	N/A
98° F - 185° F / 37° C - 85° C	98° F - 185° F / 37° C - 85° C	98° F - 185° F / 37° C - 85° C	98° F - 185° F / 37° C - 85° C
0.4 GPM (1.5 L/MIN)	0.4 GPM (1.5 L/MIN)	0.4 GPM (1.5 L/MIN)	0.4 GPM (1.5 L/MIN)
5.4 / 7.6	5.4 / 7.6	4.3 / 6.1	4.3 / 6.1
0.26 - 9.8 GPM (1.0 - 37 L/MIN)	0.26 - 9.8 GPM (1.0 - 37 L/MIN)	0.26 - 8.0 GPM (1.0 - 30 L/MIN)	0.26 - 8.0 GPM (1.0 - 30 L/MIN)
INTEGRATED	INTEGRATED	INTEGRATED	INTEGRATED
MC-91-2US	MC-91-2US	MC-91-2US	MC-91-2US
AHRI, CSA, ENERGY STAR®	AHRI, CSA, ENERGY STAR®	AHRI, CSA, ENERGY STAR®	AHRI, CSA, ENERGY STAR®
COMMERCIAL ONLY	COMMERCIAL ONLY	COMMERCIAL ONLY	COMMERCIAL ONLY
LIMITED 8-YEAR ON HEAT EXCHANGER, 5-YEAR ON PARTS, 1-YEAR ON LABOR	LIMITED 8-YEAR ON HEAT EXCHANGER, 5-YEAR ON PARTS, 1-YEAR ON LABOR	LIMITED 8-YEAR ON HEAT EXCHANGER, 5-YEAR ON PARTS, 1-YEAR ON LABOR	LIMITED 8-YEAR ON HEAT EXCHANGER, 5-YEAR ON PARTS, 1-YEAR ON LABOR
NO	NO	NO	NO
YES	YES	YES	YES
UP TO 10,200 FT. (3,109 M)	UP TO 10,200 FT. (3,109 M)	UP TO 10,200 FT. (3,109 M)	UP TO 10,200 FT. (3,109 M)
CONCENTRIC OR PVC/CPVC/PP	N/A	CONCENTRIC OR PVC/CPVC/PP	N/A
YES	YES	YES	YES
YES	YES	YES	YES
YES	YES	YES	YES
YES	YES	YES	YES

endless

quality and support

100 years of smart comfort

For nearly a century, Rinnai has been fiercely committed to delivering a smarter kind of comfort. With headquarters in Japan and a network of 20 subsidiaries and 86 sales offices in 13 countries, this commitment has made us one of the world's largest gas appliance manufacturers. Our value-added products continue to stay in step with the demands of a changing world.



The highest standards of quality

Rinnai employs more than 600 research and development engineers, all focused on uncompromising quality in design and manufacturing.

Advanced automation and precision assembly processes have made our manufacturing facilities an industry model for efficiency. Throughout the world, our standards for quality remain unsurpassed.

- Every product undergoes live testing before shipping
- One of the few tankless water heater manufacturers with its own state-of-the-art Canadian Standards Association (CSA) Certified Testing Laboratory, including CSA accredited lab technicians
- All products have been approved by the CSA and adhere to the strict standards of the American National Standards Institute (ANSI)

Learn more about Rinnai high-performance Tankless Water Heaters, Hybrid Water Heating Systems, Boilers, Vent-Free Fan Convectors and EnergySaver® Direct Vent Wall Furnaces at:

rinnai.us | rinnai.ca

Rinnai[®]
TANKLESS WATER HEATERS

Rinnai America Corporation | 103 International Drive, Peachtree City, GA 30269
800.621.9419 | rinnai.us