

Turnkey Solutions

for Exhibits and Visual Communication

RETAIL PRICING



Solution

Table of Contents

3	ULTRA-PORTABLE SOLUTIONS
4	MATCH.
8	SET.
12	ONE.
14	SPRINT.
16	BANNERSTAND COMPARISON GUIDE
17	PORTABLE SOLUTIONS
18	HELLO.SET
20	HELLO.ONE
22	HELLO.XPRESS
26	XPRESSIONS.
30	VIRAGE.
32	BLUE.
34	TABLETOPS.
36	WHY DYE-SUBLIMATION ON FABRIC?
37	WHAT IS SEG?
38	VERSATILE FABRIC WALL FRAMES
40	SCALABLE, MODULAR FRAMES
42	BOOTH SOLUTIONS
43	SMALL EXHIBIT, BIG IMPACT - 10 x 10 KITS
50	BROADEN YOUR HORIZONS WITH - 10 x 20 KITS
58	BUILD YOUR BOOTH WITH FORM & FLAIR - MODULES
72	LIGHT SOLUTIONS
73	PACKAGING SOLUTIONS
74	PORTABLE SOLUTIONS COMPARISON GUIDE
75	BOOTH SOLUTIONS COMPARISON GUIDE
76	PREPARATION & TRANSMISSION OF ART FILES
77	TRADE SHOW EXHIBITING: TIPS AND TRICKS FOR MAXIMIZING ROI

Ultra-Portable Solutions

+ Visual solutions that are easy to transport, less expensive to ship, and very simple to set-up

The Utterly Practical, Road-Warrior Retractable

Retractable Displays



double sided



case included



- + Easy to carry and set-up
- + Perfect combination of durability and elegance
- + High visual impact — choose single or double-sided with several widths available

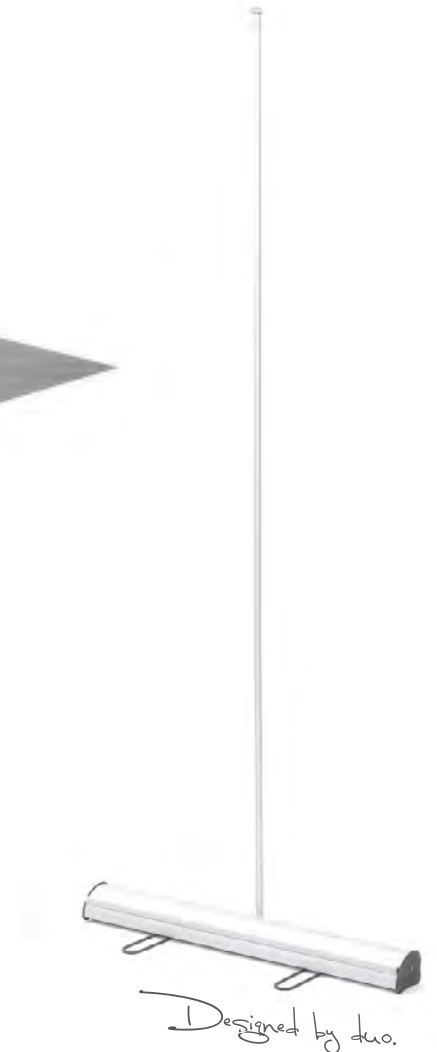

The Utterly Practical, Road-Warrior Retractable

Retractable Displays



match.460

Stand + Graphic

Qty 1	\$ 192
Qty 12	\$ 183
Qty 24	\$ 168

Product code:
MATCH-470

Graphic specs:
dye-sub on fabric, 18" x 79"



match.850

Stand + Graphic

Qty 1	\$ 290
Qty 12	\$ 278
Qty 24	\$ 252

Product code:
MATCH-850

Graphic specs:
dye-sub on fabric, 33.375" x 79"

The Utterly Practical, Road-Warrior Retractable

Retractable Displays



match.1000

Stand + Graphic

Qty 1	\$ 353
Qty 12	\$ 350
Qty 24	\$ 310

Product code:
MATCH-1000

Graphic specs:
dye-sub on fabric, 39.37" x 79"



match.1200

Stand + Graphic

Qty 1	\$ 412
Qty 12	\$ 396
Qty 24	\$ 362

Product code:
MATCH-1200

Graphic specs:
dye-sub on fabric, 47.25" x 79"

The Utterly Practical, Road-Warrior Retractable

Retractable Displays

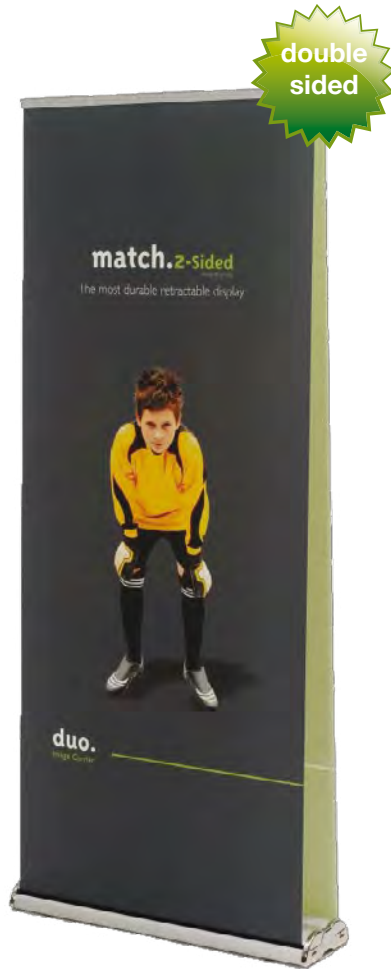

match.2sided.850

Stand + Graphics on both sides

Qty 1	\$ 698
Qty 12	\$ 670
Qty 24	\$ 615

Product code:
MATCH-2S-850

Graphic specs:
dye-sub on fabric, (2) graphics,
33.375" x 84.5" each



match.2sided.1000

Stand + Graphics on both sides

Qty 1	\$ 790
Qty 12	\$ 757
Qty 24	\$ 693

Product code:
MATCH-2S-1000

Graphic specs:
dye-sub on fabric, (2) graphics,
39.37" x 84.5" each

The Sleek Design, Multi-Functional Retractable

Retractable Displays

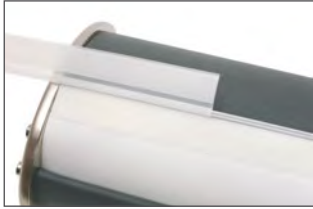

- + One of a kind design for stand-out visual communication
- + Adjustable pole for varied graphic height (35" to 88")
- + Easy change of image (ECI) system for effortless graphic exchanges
- + Light options: 50W light (\$90) or LED light (\$150)



Designed by duo.

The Sleek Design, Multi-Functional Retractable

Retractable Displays



set.600

Stand + Graphic

	48"	78"	88"
Qty 1	\$270	\$320	\$340
Qty 12	\$258	\$306	\$327
Qty 24	\$240	\$282	\$300

Product code:
SET.600

Graphic specs:
dye-sub on fabric,
23.625" x 48", 78" or 88"

23.625"

Create visual impact while
limiting the footprint



set.800

Stand + Graphic

	48"	78"	88"
Qty 1	\$308	\$372	\$398
Qty 12	\$297	\$358	\$383
Qty 24	\$273	\$330	\$352

Product code:
SET.800

Graphic specs:
dye-sub on fabric, 31.5" x 48", 78" or 88" each

The Sleek Design, Multi-Functional Retractable

Retractable Displays



set.1000

Stand + Graphic

	48"	78"	88"
Qty 1	\$370	\$440	\$470
Qty 12	\$353	\$420	\$450
Qty 24	\$327	\$388	\$413

Product code:
SET.1000

Graphic specs:
dye-sub on fabric, 39.37" x 48", 78" or 88" each



set.1200

Stand + Graphic

	48"	78"	88"
Qty 1	\$408	\$504	\$543
Qty 12	\$390	\$484	\$521
Qty 24	\$362	\$446	\$480

Product code:
SET.1200

Graphic specs:
dye-sub on fabric, 47.25" x 48", 78" or 88" each

The Sleek Design, Multi-Functional Retractable

Retractable Displays



set.2sided.800

Stand + 2 Graphics

	78"
Qty 1	\$570
Qty 12	\$542
Qty 24	\$512

Product code:
SET.800

Graphic specs:
dye-sub on fabric 31.5" x 78"

Create double-side graphic appeal by simply adding the adjustable sprint ring to your set. pole, allowing you to display a second graphic on the back of your stand

*Please note that the second graphic does not retract into the stand, but is simply removed by detaching from the ring

The No-Compromise, Low-Cost Retractable

Retractable Displays

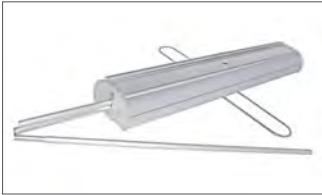

case included



- + Unbeatable price
- + Reliable 3-part bungee-corded pole & sturdy aluminum base
- + Top clipping hanger for perfect graphic tension



The No-Compromise, Low-Cost Retractable

Retractable Displays

The ideal tool for double-sided visual communication in retail and event environments



one R1

Stand + Graphic

Qty 1	\$197
Qty 12	\$197
Qty 24	\$197

Product code:
ONE.ROLLUP

Graphic specs:
dye-sub on fabric, 31.5" x 79"



one R2

Stand + Graphics

Qty 1	\$380
Qty 12	\$373
Qty 24	\$370

Product code:
ONE.ROLLUPX2

Graphic specs:
dye-sub on fabric, (2) graphics,
31.5" x 79" each

The Most Versatile Banner Display Solution

Tripod Banner Stand



case included



- + The classic and classy banner stand with infinite applications and many accessories
- + Adjustable pole for endless banner options
- + Secure, automatic set-up on its three bungee-corded feet
- + Light options: 50W light (\$90) – LED light (\$150)

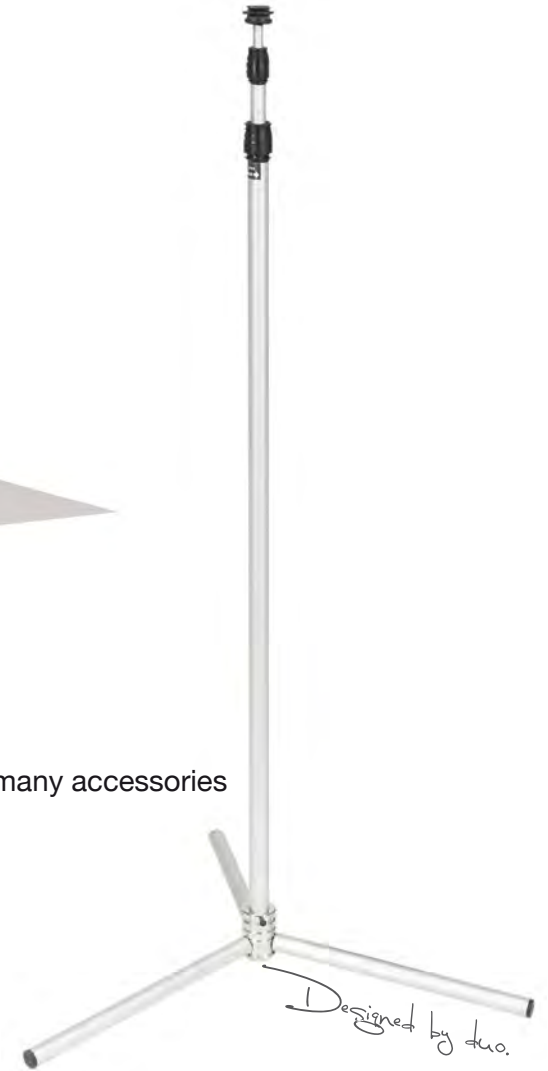

Designed by duo.



The Most Versatile Banner Display Solution

Tripod Banner Stand

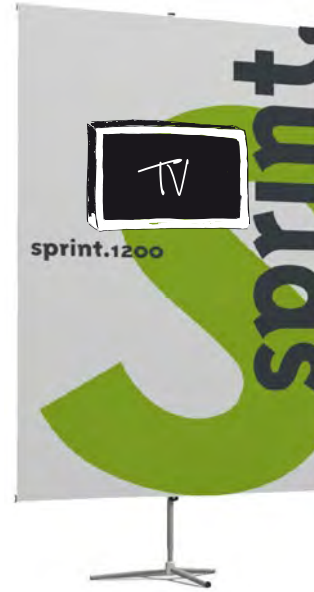
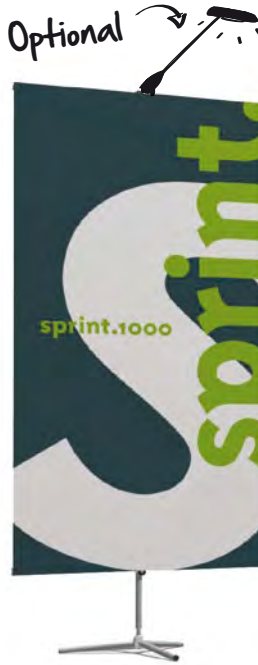
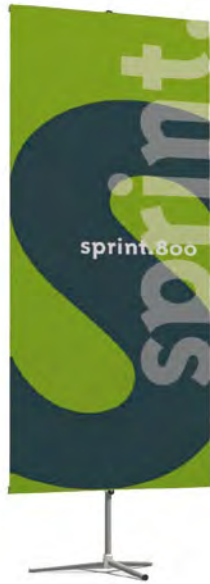
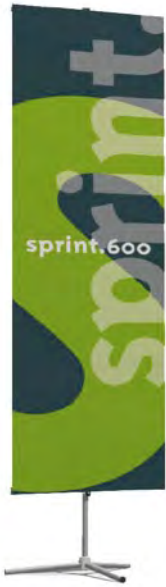

Optional monitor mount (\$150)

sprint.600

Stand + Graphic

Qty 1	\$ 263
Qty 12	\$ 252
Qty 24	\$ 233

Product code:
S-TK-600

Graphic specs:
dye-sub on fabric, 23.625" x 78"

sprint.800

Stand + Graphic

Qty 1	\$ 303
Qty 12	\$ 292
Qty 24	\$ 267

Product code:
S-TK-800

Graphic specs:
dye-sub on fabric, 31.5" x 78"

sprint.1000

Stand + Graphic

Qty 1	\$ 343
Qty 12	\$ 330
Qty 24	\$ 302

Product code:
S-TK-1000

Graphic specs:
dye-sub on fabric, 39.37" x 78"

sprint.1200

Stand + Graphic

Qty 1	\$ 393
Qty 12	\$ 378
Qty 24	\$ 345

Product code:
S-TK-1200

Graphic specs:
dye-sub on fabric, 47.25" x 78"

The sprint is adjustable from 39" to 115" in height. This is a suggested graphic height of 78", but feel free to request a quote for another graphic height

Bannerstand Comparison Guide

guide.

Ultra-Portable Displays - Features Comparison, Single-Sided

	type	width	height	pole	case included	light compatible	price range (qty 1)
match	retractable	18.5, 33.375, 39.37, or 47.25 in.	79 in. or adjustable from 33 to 79 in.	3-part bungee-corded, 3-part telescopic available for \$10	✓		\$192-\$362
set	retractable	23.625, 31.5, 39.37, or 47.25 in.	adjustable from 35 to 88 in.	3-part telescopic	✓	✓	\$270-\$480
one.R1	retractable	31.5 in.	79 in.	3-part bungee-corded	✓		\$197
sprint	tripod	23.625, 31.5, 39.37, or 47.25 in.	adjustable from 39 to 115 in.	3-part telescopic	✓	✓	\$263-\$393

Ultra-Portable Displays - Features Comparison, Double-Sided

	type	width	height	pole	case included	light compatible	price range (qty 1)
match.2sided	retractable	33.375 or 39.37 in.	84.5 in.	3-part bungee-corded	✓		\$698-\$790
set.2sided	retractable	31.5 in.	adjustable from 35 to 88 in.	3-part telescopic	✓	✓	\$570
one.R2	retractable	31.5 in.	79 in.	3-part bungee-corded	✓		\$380

Portable Solutions

- + Solutions ideal for travel by car or for shipping (sturdy, durable packaging)
- + Weight is less than 125 lbs
- + Easily set-up by one person

Top of the Line Roadshow Favorite

All-In-One Kit



- + Sleek-design and multifunctional all-in-one kit
- + Adjustable height retractables with ECI system add versatility and reusability
- + Ideal kit for roadshows, recruitment events, training seminars, or sales conferences
- + Light options: 50W light (\$90) - LED light (\$150)

Top of the Line Roadshow Favorite



All-In-One Kit



hello.set

Stands + Counter + Graphics

Qty 1 \$ **1,491**

Qty 12 \$ **1,445**

Qty 24 \$ **1,364**

Product code:
DH2-K-SET

Graphic specs:
dye-sub on fabric, (2) graphics, 31.5"
(w) x 35 to 88"(h) for set retractables,
(1) dye-sub fabric wrap, 93.7" (w) x
36.6" (h) for hello.counter

10x10 on a Budget

All-In-One Kit



- + Efficient and economical all-in-one kit for a 10x10 booth
- + Rolling case-to-counter holds everything you need for your exhibit
- + Configure your space – create a backwall with retractables for visual interest

10x10 on a Budget

All-In-One Kit



hello.one

Stands + Counter + Graphics

Qty 1	\$1,328
Qty 12	\$1,302
Qty 24	\$1,266

Product code:
DH2-K-ONE

Graphic specs:
dye-sub on fabric, (3) graphics, 31.5" (w) x 79" (h) for one retractables, (1) dye-sub fabric wrap, 93.7" (w) x 36.6" (h) for hello.counter

Pop-Up your 10x10 in less than 10 Minutes

All-In-One Kit



- + Simple, lightweight solution for a 10x10 booth
- + Fabric skins are unique and easy to maneuver for 3D graphic appeal
- + Crash-tested rotomolded case turns into a sturdy display counter to hold a laptop, demo products, or marketing handouts
- + Light option: 50W light (\$90) — LED light (\$150)

Pop-Up your 10x10 in less than 10 Minutes



Graphics printed by Optima Graphics

All-In-One Kit

See www.xpressions-snap.com for even more configurations!



hello.xpress

Frame + Counter + Graphics

Qty 1	\$ 3,098
Qty 3	\$ 3,006
Qty 6	\$ 2,912

Product code:
HELLO-XPRESS

Graphic specs:
Please request templates and graphic prep guide

Pop-Up your 10x10 in less than 10 Minutes



All-In-One Kit

Each one of these kits fits into this case-to-counter solution!



Qty 1 **\$2,654**

Product code:
HELLO-XPRESS-A-1



Qty 1 **\$3,190**

Product code:
HELLO-XPRESS-B



Qty 1 **\$3,484**

Product code:
HELLO-XPRESS-D

Pop-Up your 10x10 in less than 10 Minutes

hello.xpress

Graphics printed by Optima Graphics

All-In-One Kit

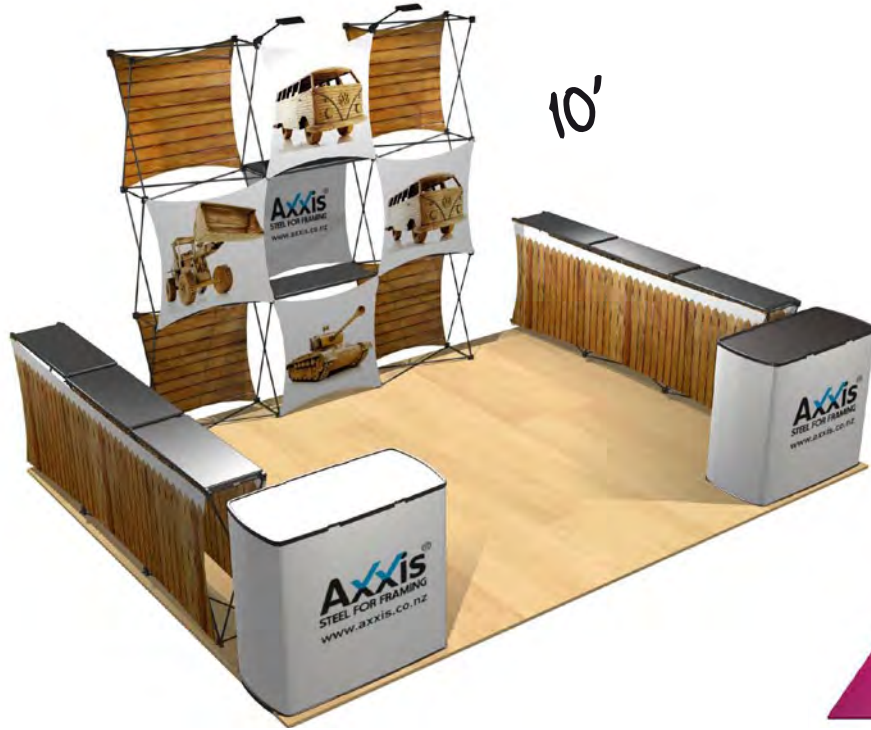

10'



20'

Qty 1 \$6,550

Product code:
HELLO-XPRESS-10-EXTRA

Each one of these kits fits into 2 cases-to counter solution!



x 2

Qty 1 \$8,105

Product code:
HELLO-XPRESS-20-B*

The Most Creative Pop-Up Display

All-in-one Kit



case optional



- + Lightweight solution that comes in all shapes and sizes
- + Graphically driven and visually interesting to spotlight your message
- + Fabric skins are easy to exchange and maneuver for 3D graphic appeal
- + Light option: 50W light (\$90) – LED light (\$150)

The Most Creative Pop-Up Display

xpressions.

Graphics printed by Optima Graphics

All-in-one Kit



xpressions.4x3

Frame + Graphics + Bag

Qty 1 **\$3,576**

Product code:
KIT-XPR-4X3



xpressions.3x3

Frame + Graphics + Bag

Qty 1 **\$2,450**

Product code:
KIT-XPR-3X3A



xpressions.3x3

Frame + Graphics + Shelves + Bag

Qty 1 **\$2,780**

Product code:
XPRESSIONS-3X3B



The Most Creative Pop-Up Display

All-in-one Kit



xpressions.2x3

Frame + Graphics + Bag

Qty 1 \$1,750

Product code:
KIT-XPR-2X3

xpressions.1x3

Frame + Graphics +
Shelves + Bag

Qty 1 \$835

Product code:
KIT-XPR-1X3

xpressions.pyramid xl

Frame + Graphics + Bag

Qty 1 \$2,817

Product code:
KIT-XPR-PYRAMID-XL

xpressions.pyramid S

Frame + Graphics + Bag

Qty 1 \$892

Product code:
KIT-XPR-PYRAMID

The Most Creative Pop-Up Display

xpressions.

Graphics printed
by Optima Graphics

All-in-one Kit



xpressions.argyle

Frame + Graphics + Bag

Qty 1 \$**2,946**

Product code:
KIT-XPR-ARGYLE-1

xpressions.argyle

Frame + Graphics + Bag

Qty 1 \$**2,322**

Product code:
KIT-XPR-ARGYLE-2

xpressions.cross

Frame + Graphics + Bag

Qty 1 \$**1,402**

Product code:
XPRESSIONS-CROSS

The Fashionable Fabric Backwall

that Sets-Up in Seconds

Pop-Up Displays



- + Mobile backwall solution perfect for roadshows, 10x10 booths, or retail environments
- + Automatic set-up provides instant visual impact. Easy-to-use hook and loop strips for secure graphic attachment
- + Fabric graphic stays connected to the frame and wrinkle-free, even when folded
- + Optional case with graphic wrap: \$390
- + Light option: 50W light (\$90) — LED light (\$150)

The Fashionable Fabric Backwall

that Sets-Up in Seconds

Pop-Up Displays

virage.3x3

Frame + Graphic

Qty 1	\$1,098
Qty 6	\$1,086
Qty 12	\$1,013

Product code:
VIR-K-D33

Graphic specs:
dye-sub on fabric, 116.9" x 88.2"
including end-caps Optional case and
graphic wrap \$390

virage.4x3

Frame + Graphic

Qty 1	\$1,363
Qty 6	\$1,346
Qty 12	\$1,255

Product code:
VIR-K-D33

Graphic specs:
dye-sub on fabric, 146.5" x 88.2"
including end-caps Optional case and
graphic wrap \$390



The Classic Pop-Up Stand for Elegant

Visual Appeal

Pop-Up Displays



- + Complete display kit (frame, graphics, case, and lights)
- + Elegant design
- + Many accessories available
- + Sturdy, rotomolded case included
- + Optional case-to-counter conversion kit: \$180
- + Optional counter wrap: \$196

The Classic Pop-Up Stand for Elegant

blue.

Pop-Up Displays

Visual Appeal

case included



blue.3x3 curved

Frame + Graphic + Case
+ (2) 200W spotlights

Qty 1	\$ 2,138
Qty 12	\$ 2,080
Qty 24	\$ 2,023

Product code:
OB-S-R33CU-KIT

Graphic specs:
3 front panels and 2 printed endcaps
on laminated PVC. Please ask for
templates.



blue.4x3 curved

Frame + Graphic + Case
+ (2) 200W spotlights

Qty 1	\$ 2,431
Qty 12	\$ 2,374
Qty 24	\$ 2,312

Product code:
OB-S-R43CU-KIT

Graphic specs:
4 front panels and 2 printed endcaps
on laminated PVC. Please ask for
templates.

Unique & Portable Tabletops



Tabletop Displays



- + Simple, polished tabletop solutions with ample space for your marketing message
- + Wrinkle-resistant fabric graphics with vibrant colors and long-lasting results
- + Included 50W spotlights illuminate your visual communication

Unique & Portable Tabletops

tabletops.

Tabletop Displays

2' x 2'

6' x 4'

6' x 4'



blue.2x2

Frame + Graphic + Case
+ (2) 50W spotlights

Qty 1	\$1,293
Qty 12	\$1,254
Qty 24	\$1,215

Product code:
OB-S-R22CU-KIT

Graphic specs:
2 front panels and 2 printed endcaps
on laminated PVC. Please ask for
templates.

mercure.6x4

Frame + Graphic
includes (4) 50w lights

Qty 1	\$998
Qty 12	\$965
Qty 24	\$932

Product code:
MER-TT-F16

Graphic specs:
dye-sub on fabric with silicone edging
(SEG), 72" x 47"
Also available in 4x3' (\$765)

set.600

Stand + Graphic

Qty 1	\$810
Qty 12	\$770
Qty 24	\$729

Product code:
SET-600-TT

Graphic specs:
dye-sub on fabric, (3) graphics,
23.625" x 48"

Why Dye-Sublimation on Fabric?

dye sub.

Fabric graphics enable easy transport, installation, and manipulation. They are wrinkle and stain-resistant and can even be dry-cleaned. Using the dye-sublimation printing process, the fabric fibers are directly dyed, which improves the durability of colors over time.

Advantages:

- + Intense colors: dye-sub provides a quality of contrast, intensity, and depth that is unparalleled
- + Anti-reflective: the sublimated fabric absorbs light and thus eliminates any reflections on your image
- + Eco-friendly process: the printing process and the inks used are environmental solutions without solvents or harsh odors





What is SEG?

SEG (Silicone Edge Graphic) is the combination of a dye-sublimation fabric graphic with a thin silicone strip sewn directly to its edges. This strip is inserted into the groove of our aluminum frames to produce a seamless, large format graphic that mimics the old-fashioned rigid panel graphics commonly found on exhibits and interior signage.

Why choose SEG?

- + Quicker set-up = lower labor costs. SEG graphics are easy to install and dismantle
- + Lightweight = lower shipping & drayage costs. SEG graphics weigh significantly less than other print media, making them simple to carry, ship, and store
- + Seamless and Polished Finish. SEG graphics stretch taught over the frame without seams, lines, or wrinkles for a true mark of quality on your booth

Versatile Fabric Wall Frames

mercure.

Fabric Wall Frames

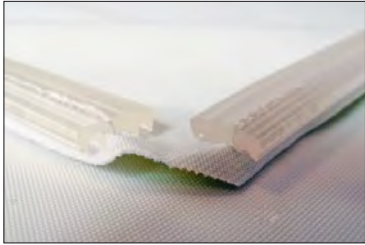

- + Aluminum frames available in many sizes for retail, museums, business interiors, and virtually any environment
- + Ergonomic hardware for simple set-up — no expertise required
- + Silicone edge graphics enable infinite, effortless graphic exchanges

Versatile Fabric Wall Frames



Fabric Wall Frames

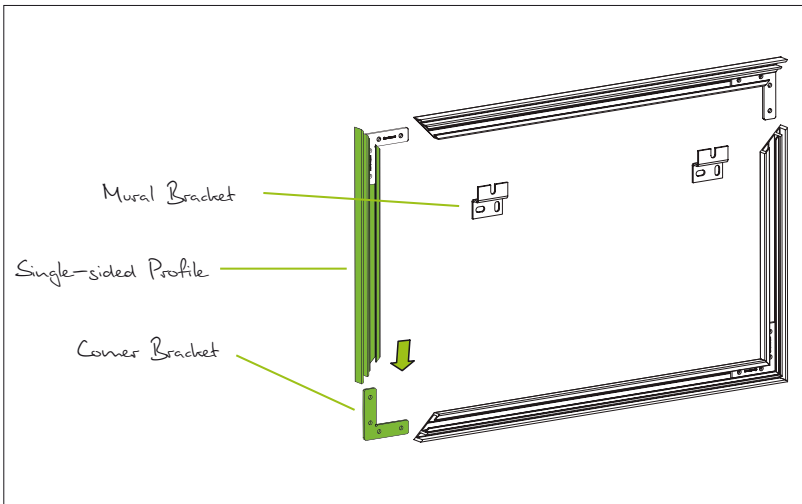
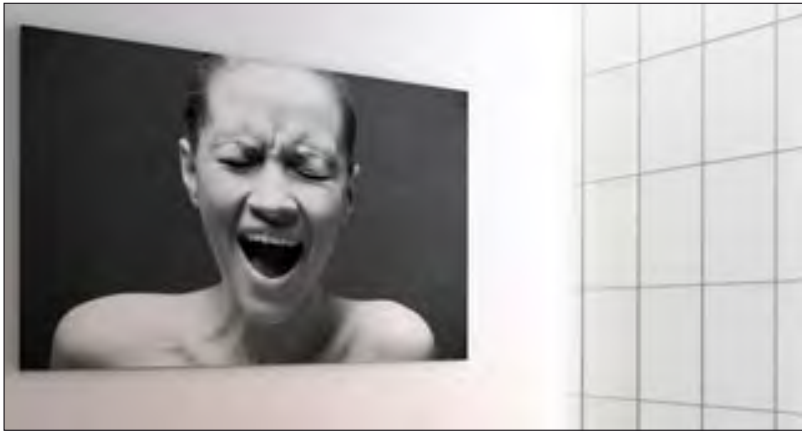

mercure.

Frame + Graphic

width

	2'	3'	4'	5'	6'	7'	8'
2'	\$145	\$183	\$223	\$262	\$300	\$338	\$377
3'	\$183	\$237	\$288	\$340	\$392	\$443	\$497
4'	\$223	\$288	\$353	\$418	\$483	\$550	\$615
5'	\$262	\$340	\$418	\$497	\$577	\$655	\$733
6'	\$300	\$392	\$483	\$577	\$668	\$760	\$852
7'	\$338	\$443	\$550	\$655	\$760	\$865	\$970
8'	\$377	\$497	\$615	\$733	\$852	\$970	\$1090

height

Graphic specs:

Design your art file to the same size as your frame, keeping all critical text and images 2" from all edges

Scalable, Modular Frames

mercure.

Free-Standing Fabric Frames



for Display Communication



- + Fantastic solution for trade show booths, point of purchase signage, or retail lobbies
- + Plethora of accessories available, including shelves, brochure holders, and monitor attachments
- + Choose from single or double-sided solutions fit to your unique needs

Scalable, Modular Frames



for Display Communication

Free-Standing Fabric Frames



- Options:**
- + Case (interior dim: 11.5" x 44.5") for frames up to 7.5 ft in any direction
 - + Stabilizing foot: \$20, for frames less than 5 ft. tall
 - + Arch foot: \$40, for frames more than 5 ft. tall
 - + LED Light Kit: \$300, (2) LED spotlights
 - + Halogen Light Kit: \$200, (2) 200W spotlights

Product code:
MERCURE

Graphic specs:
Design your art file to the same size as your frame, keeping all critical text and images 2" from all edges



single sided

Prices for frame and graphic on one side

height

	width						
	2'	3'	4'	5'	6'	7'	8'
2'	\$170	\$210	\$250	\$322	\$362	\$400	\$440
3'	\$210	\$262	\$312	\$397	\$447	\$498	\$550
4'	\$250	\$312	\$375	\$470	\$533	\$597	\$658
5'	\$322	\$397	\$470	\$578	\$653	\$727	\$802
6'	\$362	\$447	\$533	\$653	\$738	\$825	\$893
7'	\$400	\$498	\$597	\$727	\$825	\$922	\$1020
8'	\$440	\$550	\$658	\$802	\$802	\$1020	\$1130



double sided

Price for frame and graphics on both sides

height

	width						
	2'	3'	4'	5'	6'	7'	8'
2'	\$217	\$280	\$343	\$438	\$502	\$563	\$627
3'	\$280	\$367	\$452	\$572	\$657	\$723	\$830
4'	\$343	\$452	\$562	\$703	\$813	\$923	\$1032
5'	\$438	\$572	\$703	\$870	\$1003	\$1135	\$1268
6'	\$502	\$657	\$813	\$1003	\$1158	\$1315	\$1470
7'	\$563	\$743	\$923	\$1135	\$1315	\$1493	\$1673
8'	\$627	\$830	\$1032	\$1268	\$1470	\$1673	\$1877

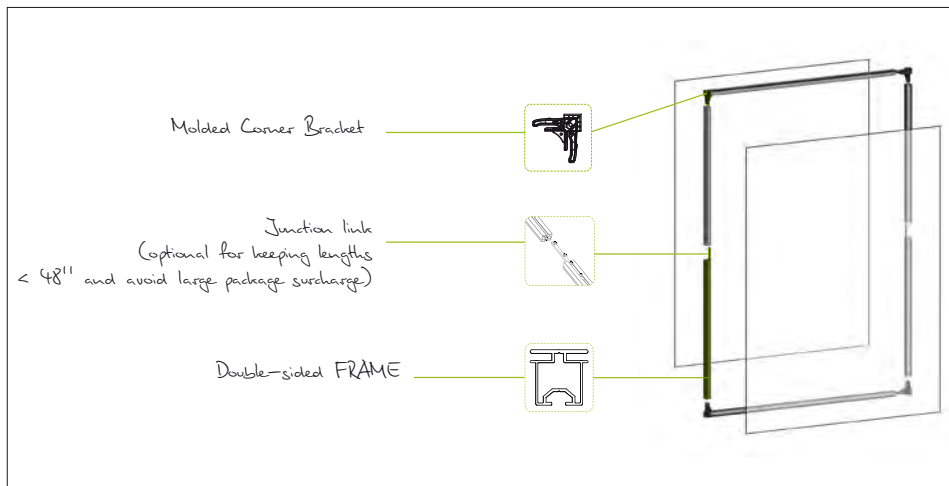

Booth Solutions

+ solutions ideal for travel by car or for shipping (sturdy, durable packaging)

Small Exhibit, Big Impact

10'x10' Booths



- + Compact and easy to ship 10x10 kits with lightweight, foldable fabric graphics
- + All configurations are complete, no extra parts needed and no hidden costs
- + Simple, streamlined set-up. Smart and easy-to-follow instructions using only one or zero tools
- + Wide range of accessories available, including shelves, brochure racks, lights, monitor mounts, backlighting, and more

Small Exhibit, Big Impact

10'x10' Booths



Hardware + Graphics
+ 2 lights

purchase* \$**3,990**

rental* \$**2,690**

* chair not included -----

Product code:
MER-10X10-K6

Total Weight:
150 lbs

storage area	✓
shelves	
billboard-style panel	✓
counter	
lights	✓
brochure holders	
monitor mount	

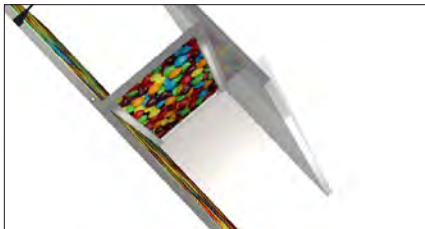
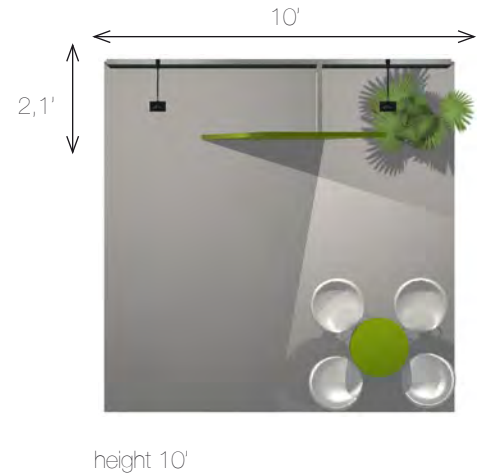

storage area

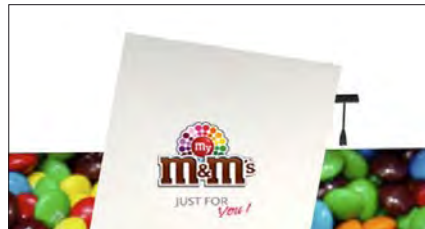

sleek frame & billboard-style panel

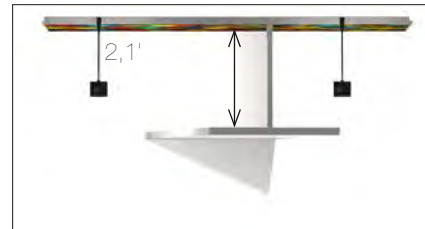

small footprint

Small Exhibit, Big Impact



10'x10' Booths

Retractable banners have 31.5" x 78" (17 sq. ft.) of visible graphic area



Hardware + Graphics + 4 lights

purchase* \$4,790

rental* \$2,880

* chair not included

Product code:
MER-10X10-K4

Total Weight:
117 lbs

storage area	✓
shelves	
billboard-style panel	
counter	✓
lights	✓
brochure holders	✓
monitor mount	

Counter fully wrapped with a stretchable fabric sleeve

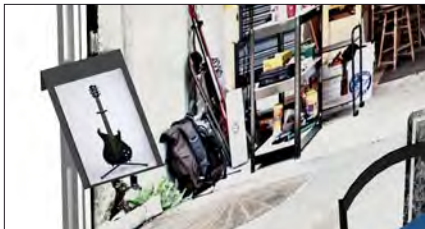

2 brochure holders



retractable banner

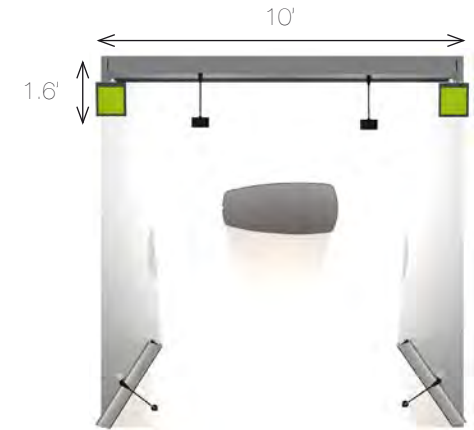

standard height 8'

Small Exhibit, Big Impact

10'x10' Booths



Hardware + Graphics
+ 2 lights

purchase* \$**6,065**

rental* \$**3,230**

* chair not included

Product code:
MER-10X10-K2

Total Weight:
220 lbs

storage area	✓
shelves	✓
billboard-style panel	✓
counter	✓
lights	✓
brochure holders	
monitor mount	

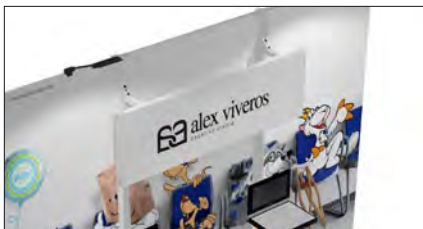
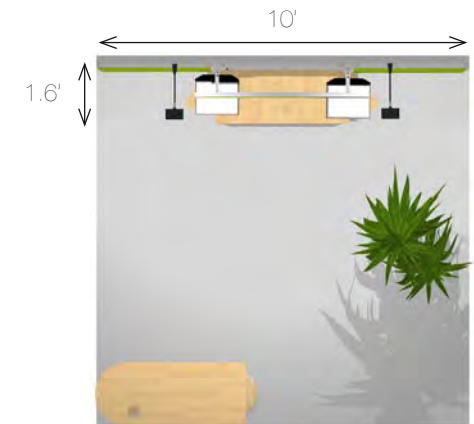

stand-off billboard-style panel

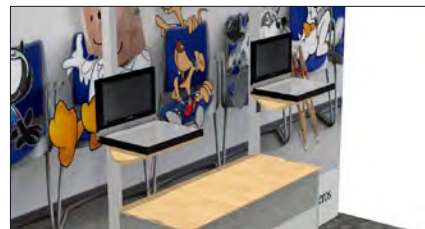

shelves & storage space



counter with double-sided graphics

standard height 8'

Small Exhibit, Big Impact

10'x10' Booths



mercure.

Hardware + Graphics

purchase* \$6,490

rental* \$4,790

* stools and table not included

Product code:
MER-10X10-K5

Total Weight:
225 lbs

storage area	
shelves	
billboard-style panel	
counter	
lights	
brochure holders	✓
monitor mount	

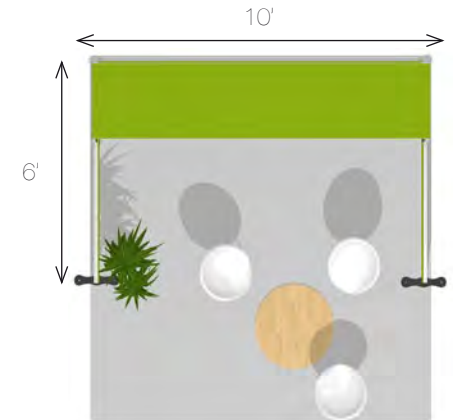

canopy



brochure holder

standard height 8'

Small Exhibit, Big Impact

10'x10' Booths



mercure.

Hardware + Graphics
+ 2 lights

purchase* \$**6,880**

rental* \$**3,410**

* bench not included -----

Product code:
MER-10X10-K1

Total Weight:
220 lbs

storage area	✓
shelves	✓
billboard-style panel	✓
counter	✓
lights	✓
brochure holders	✓
monitor mount	✓

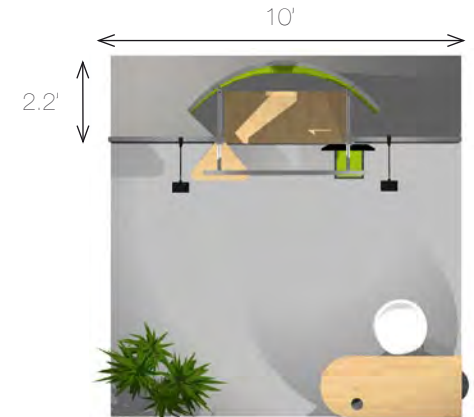

curved panel

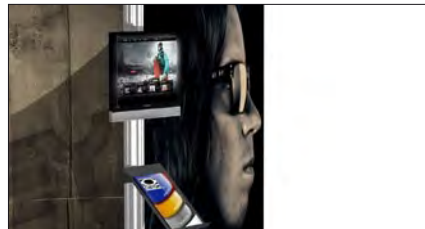

monitor mount & brochure holder

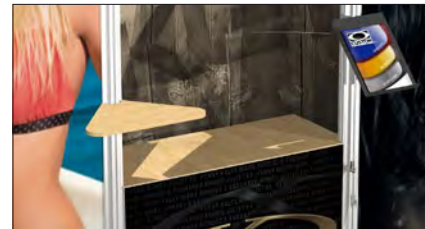

shelf & storage space

standard height 8'

Small Exhibit, Big Impact

10'x10' Booths

Uniquely shaped, multi-functional 10x10 booth with storage area (with door), varied height side walls, plus front reception counter



mercure.

Hardware + Graphics + 2 lights

purchase* \$8,920
rental* \$5,100

* stools not included

Product code:
MER-10X10-K3

Total Weight:
225 lbs

storage area	✓
shelves	
billboard-style panel	
counter	✓
lights	✓
brochure holders	✓
monitor mount	



storage area



brochure holder



double-sided graphics

Broaden Your Horizons with 10 x 20 Kits

mercure.

10'x20' Booths



- + Expand your marketing creativity with more space and a large surface to promote your message
- + Be your own booth architect. Choose between wide, open space and partitioned segments. Add visual interest with storage spaces and varied depth
- + Simple, streamlined set-up. Smart and easy-to-follow instructions using only one or zero tools
- + Wide range of accessories available, including shelves, brochure racks, lights, monitor mounts, backlighting, and more

Broaden Your Horizons with 10 x 20 Kits

mercure.

10'x20' Booths



Hardware + Graphics
+ 3 lights

purchase* \$7,990

rental* \$5,645

* armchairs not included

Product code:
MER-10X20-K6

Total Weight:
470 lbs

storage area	✓
shelves	✓
billboard-style panel	✓
counter	✓
lights	✓
brochure holders	✓
monitor mount	✓



sturdy shelves

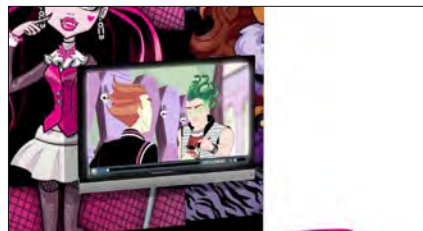

monitor mount



brochure holder



height 9'

Broaden Your Horizons with 10 x 20 Kits



10'x20' Booths



Hardware + Graphics
+ 5 lights

purchase* \$ **8,990**

rental* \$ **5,170**

* armchair not included

Product code:
MER-10X20-K5

Total Weight:
250 lbs

storage area	
shelves	
billboard-style panel	
counter	✓
lights	✓
brochure holders	
monitor mount	



zig-zag effect



double-sided graphics

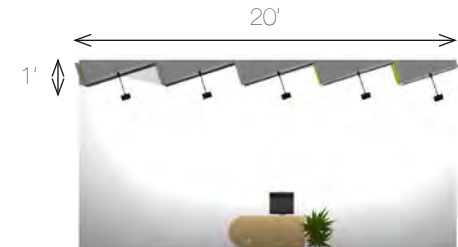

standard height 8'

Broaden Your Horizons with 10 x 20 Kits



10'x20' Booths



Storage area with door

Hardware + Graphics
+ 3 lights

purchase* \$ **9,490**

rental* \$ **6,240**

* stools and table not included

Product code:
MER-10X20-K7

Total Weight:
330 lbs

storage area	✓
shelves	
billboard-style panel	✓
counter	
lights	✓
brochure holders	✓
monitor mount	✓



storage area



billboard-style panel



brochure holder



height 10'

Broaden Your Horizons with 10 x 20 Kits

mercure.

10'x20' Booths

Large storage area with door

Brochure holder



Hardware + Graphics
+ 3 lights

purchase* \$ **10,250**

rental* \$ **6,390**

* chairs and table not included

Product code:
MER-10X20-K3

Total Weight:
295 lbs

storage area	✓
shelves	
billboard-style panel	
counter	✓
lights	✓
brochure holders	✓
monitor mount	



storage area



brochure holder & monitor mount



double-sided graphics



standard height 8'

Broaden Your Horizons with 10 x 20 Kits



10'x20' Booths

2 storage spaces

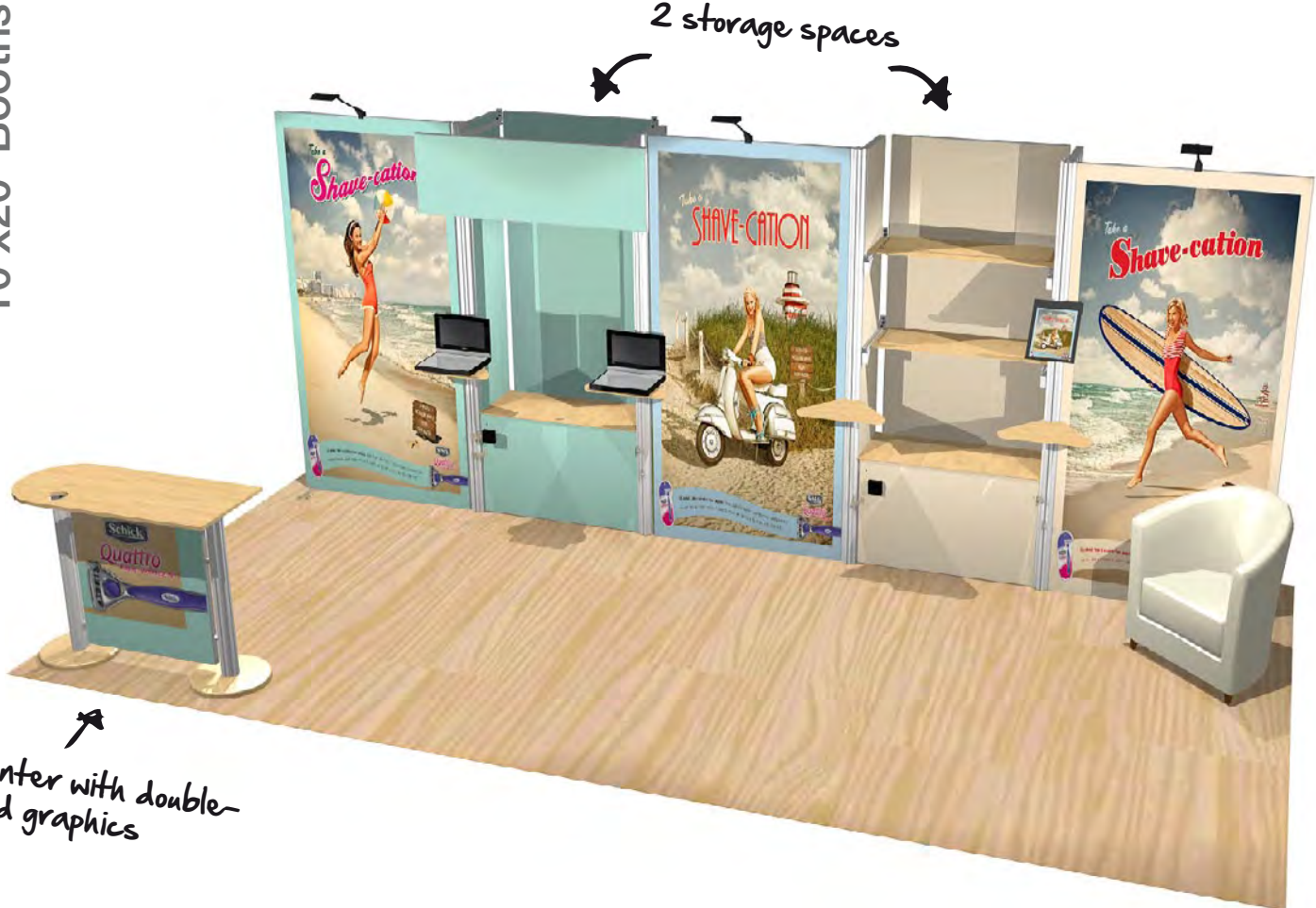

Counter with double-sided graphics

Hardware + Graphics
+ 3 lights

purchase* \$ **11,410**

rental* \$ **5,880**

* armchair and laptops not included

Product code:
MER-10X20-K2

Total Weight:
360 lbs

storage area	✓
shelves	✓
billboard-style panel	✓
counter	✓
lights	✓
brochure holders	✓
monitor mount	



billboard-style panel

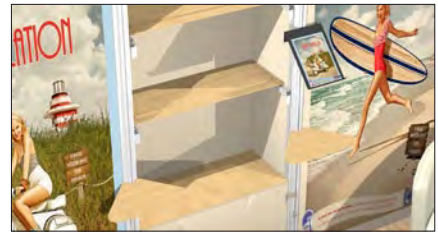

sturdy shelves & storage space



double-sided graphics



standard height 8'

Broaden Your Horizons with 10 x 20 Kits



10'x20' Booths



Hardware + Graphics
+ 3 lights

purchase* \$ **11,900**

rental* \$ **7,540**

* stools not included

Product code:
MER-10X20-K4

Total Weight:
345 lbs

storage area	✓
shelves	
billboard-style panel	✓
counter	✓
lights	✓
brochure holder	✓
monitor mount	



storage area



brochure holder



height 10'

Broaden Your Horizons with 10 x 20 Kits



10'x20' Booths

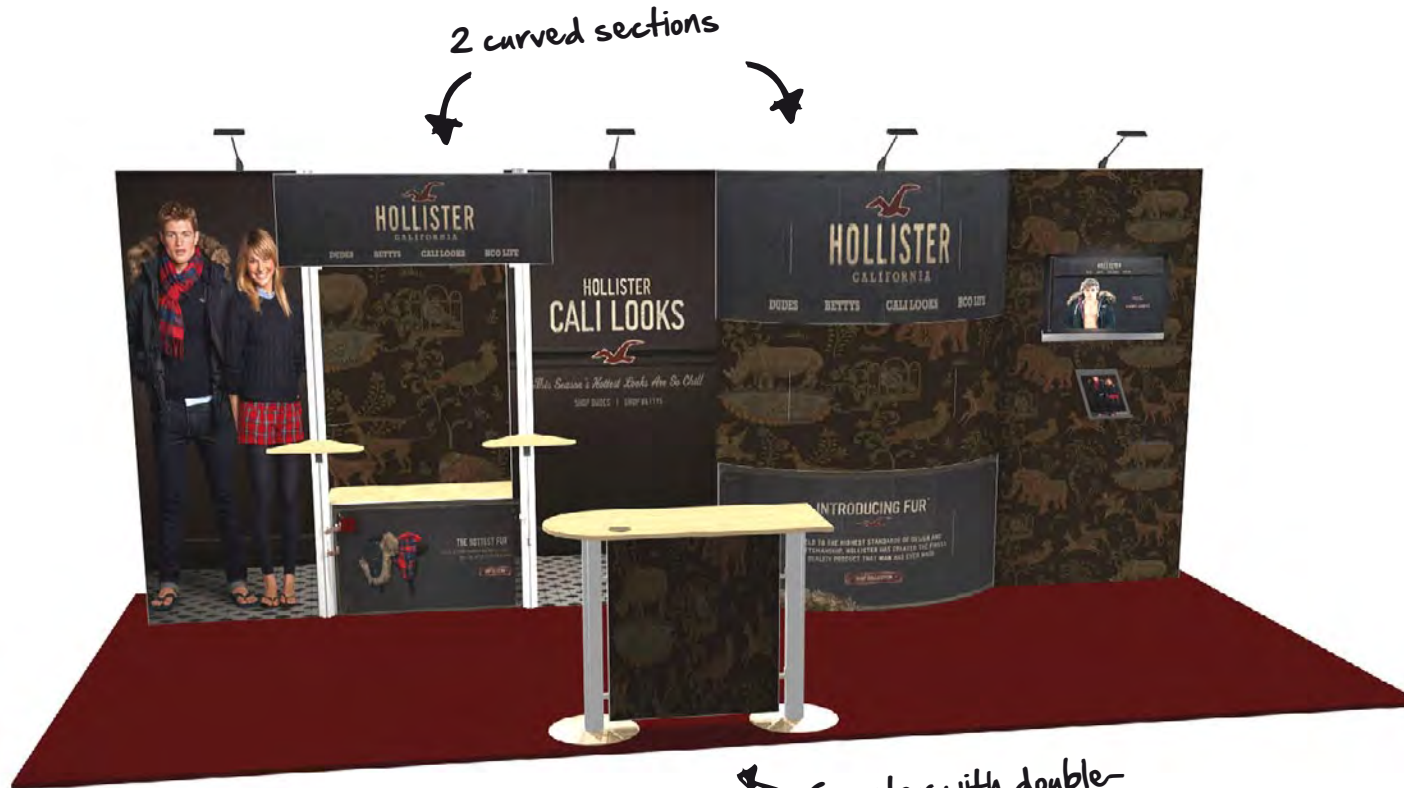

Hardware + Graphics
+ 4 lights

purchase* \$ **12,290**

rental* \$ **6,060**

Product code:
MER-10X20-K1

Total Weight:
300 lbs

storage area	✓
shelves	✓
billboard-style panel	✓
counter	✓
lights	✓
brochure holders	✓
monitor mount	✓

Counter with double-sided graphics



storage space



elegant design - 2 curved sections



elegant design - 2 curved sections



standard height 8'

Build Your Booth With Form & Flair



Modules



- + Make your booth work for you! Add functionality with practical brochure holders, TV monitor stands, counters, & shelving units
- + All modules feature durable components and easily changeable fabric graphics for repeat use
- + Modules add visual interest to 10x10 or 10x20 booths and are also great for retail applications

Build Your Booth With Form & Flair



Modules



Hardware + Graphics

purchase* \$ **730**
 rental* \$ **425**

Product code:
MER-MOD-K10

Total Weight:
 22 lbs

storage area	
shelves	
billboard-style panel	✓
counter	
lights	
brochure holders	
monitor mount	



double-sided graphics

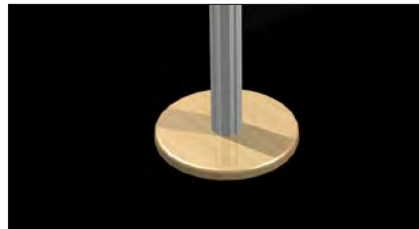

wooden base

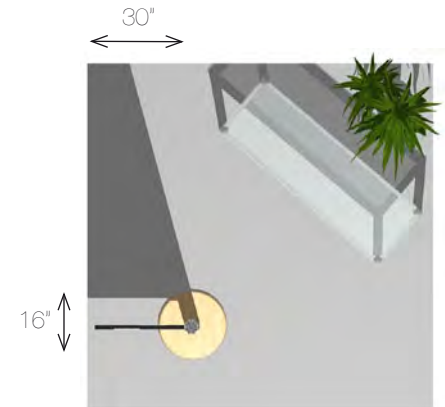

height 8'

Build Your Booth With Form & Flair

Modules



Hardware + Graphics

purchase* \$**850**

rental* \$**480**

Product code:
MER-MOD-K12

Total Weight:
24 lbs

storage area	
shelves	✓
billboard-style panel	✓
counter	
lights	
brochure holders	
monitor mount	✓



shelf



monitor mount

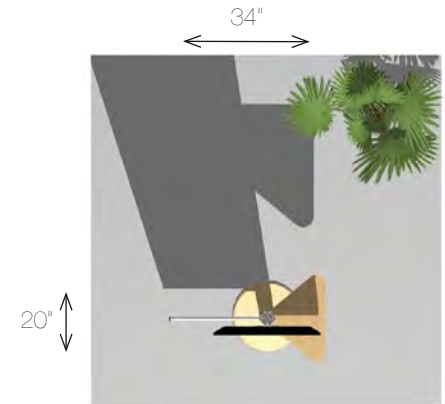

height 8'

Build Your Booth With Form & Flair

Modules

mercure.

Hardware + Graphics

purchase* \$ **999**

rental* \$ **530**

Product code:
MER-MOD-K11

Total Weight:
28 lbs



3 brochure holders

storage area	
shelves	
billboard-style panel	✓
counter	
lights	
brochure holders	✓
monitor mount	

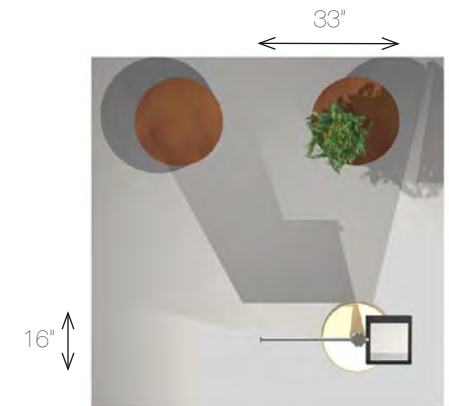

height 8'

Build Your Booth With Form & Flair



Modules



Hardware + Graphics

purchase* \$ **1,620**
 rental* \$ **1,120**

Product code:
MER-MOD-K13

Total Weight:
 28 lbs

storage area	
shelves	
billboard-style panel	✓
counter	
lights	
brochure holders	
monitor mount	



4 double-sided graphics

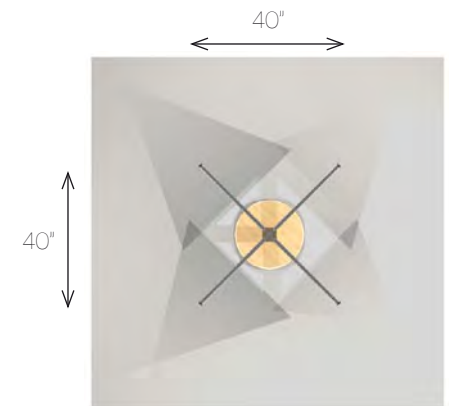

height 8'

Build Your Booth With Form & Flair



Modules

Rolling kiosk with storage space and wheels to enable easy transport and relocation. Infinite applications in trade shows, events, or retail



Hardware + Graphics

purchase* \$**3,200**
 rental* \$**1,560**

Product code:
MER-MOD-K8

Total Weight:
 145 lbs

storage area	✓
shelves	✓
billboard-style panel	✓
counter	
lights	✓
brochure holders	✓
monitor mount	

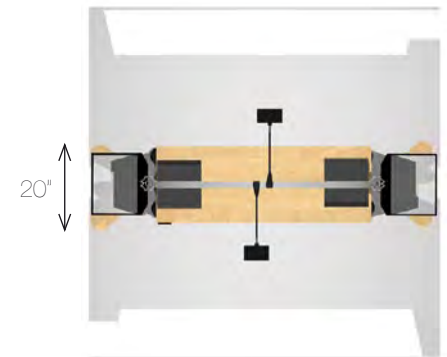

4 shelves & 2 brochure holders



module on wheels

Build Your Booth With Form & Flair



Modules

Ample space for laptops or lead retrieval systems



double-sided graphics

Hardware + Graphics

purchase* \$ **970**

rental* \$ **490**

Product code:
MER-MOD-K1

Total Weight:
60 lbs

storage area	
shelves	
billboard-style panel	
counter	✓
lights	
brochure holders	
monitor mount	

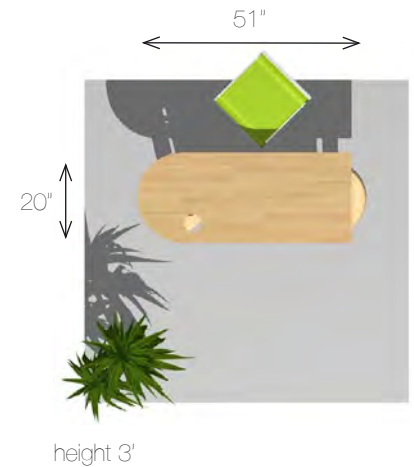

Build Your Booth With Form & Flair



Modules

Compact and multi-functional module that combines three practical applications into one piece: printed flag, video presentation module, and reception counter all in one!



Hardware + Graphics

purchase* \$1,460
rental* \$760

Product code:
MER-MOD-K5

Total Weight:
87 lbs

storage area	✓
shelves	✓
billboard-style panel	✓
counter	✓
lights	
brochure holders	
monitor mount	✓

63" width dimension

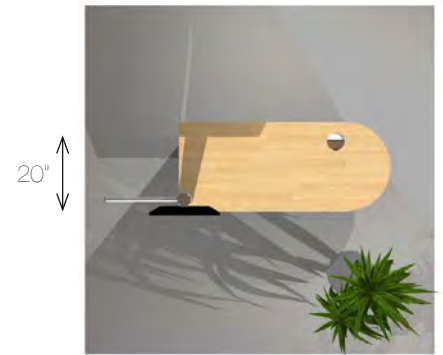

height 7'



shelf and storage space



monitor mount

Build Your Booth With Form & Flair



Modules

Display products, giveaways, or laptops on this practical and space-saving counter



Hardware + Graphics

purchase* \$1,490
rental* \$850

Product code:
MER-MOD-K2

Total Weight:
80 lbs

storage area	✓
shelves	✓
billboard-style panel	
counter	✓
lights	
brochure holders	
monitor mount	

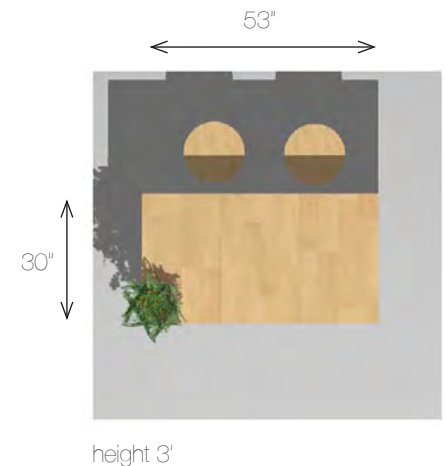

shelf and storage space

Build Your Booth With Form & Flair



Modules

Elegant curved counter.
Great for tradeshows, events
or retail applications



rounded counter

Hardware + Graphics

purchase* \$1,720

rental* \$1,020

Product code:
MER-MOD-K4

Total Weight:
135 lbs

storage area	✓
shelves	
billboard-style panel	
counter	✓
lights	
brochure holders	
monitor mount	

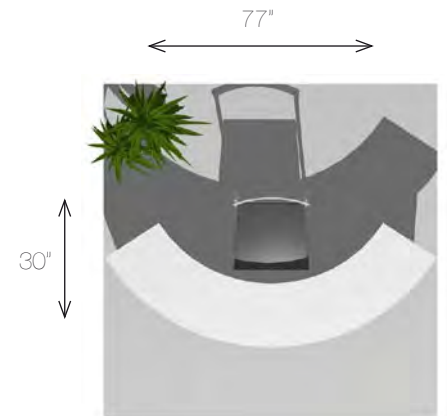

height 3'

Build Your Booth With Form & Flair

Modules

Large reception counter with a sturdy interior shelf

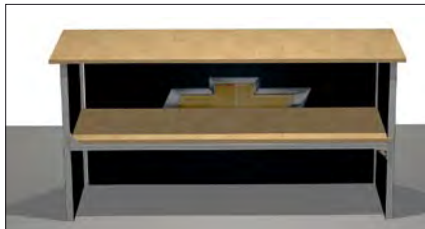

shelf and large storage space

mercure.

Hardware + Graphics

purchase* **\$1,990**

rental* **\$1,090**

Product code:
MER-MOD-K3

Total Weight:
115 lbs

storage area	✓
shelves	✓
billboard-style panel	
counter	✓
lights	
brochure holders	
monitor mount	

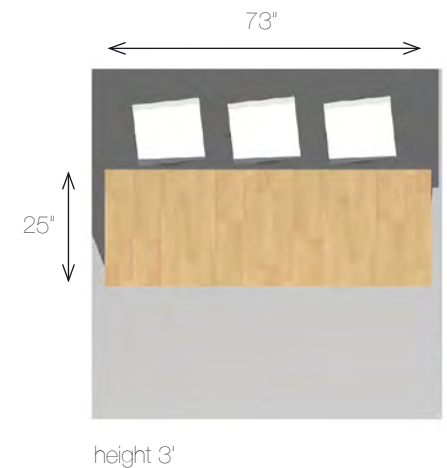

Build Your Booth With Form & Flair



Modules

Rolling kiosk, easy to transport and relocate. Infinite applications in trade shows, events, or retail



Hardware + Graphics

purchase* \$ **1,990**

rental* \$ **1,070**

Product code:
MER-MOD-K9

Total Weight:
120 lbs

storage area	
shelves	✓
billboard-style panel	✓
counter	
lights	
brochure holders	✓
monitor mount	

46"
↔

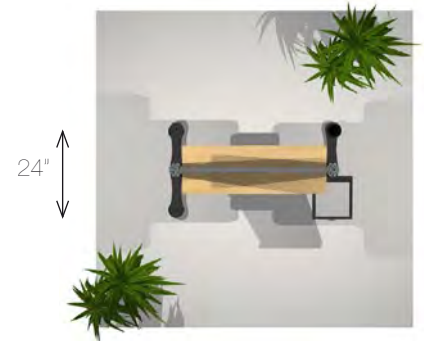

24"
↑
↓

height 7'

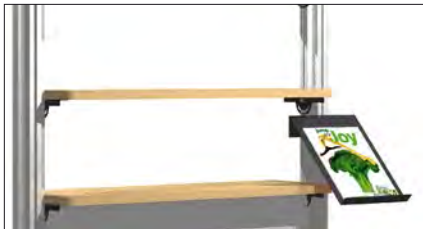

3 shelves & 1 brochure holder



module on wheels



billboard-style panel

Build Your Booth With Form & Flair



Modules

Slim booth kiosk with storage space & billboard-style panel single-sided graphic



Hardware + Graphics

purchase* \$ **2,295**

rental* \$ **1,120**

Product code:
MER-MOD-K7

Total Weight:
85 lbs

storage area	✓
shelves	
billboard-style panel	✓
counter	✓
lights	
brochure holders	✓
monitor mount	✓

47"
↔

21"
↑↓



height 8'



brochure holder



monitor mount



counter and storage space

Build Your Booth With Form & Flair



Modules

Practical and appealing kiosk module ideal for retail and event applications. Single-sided graphics

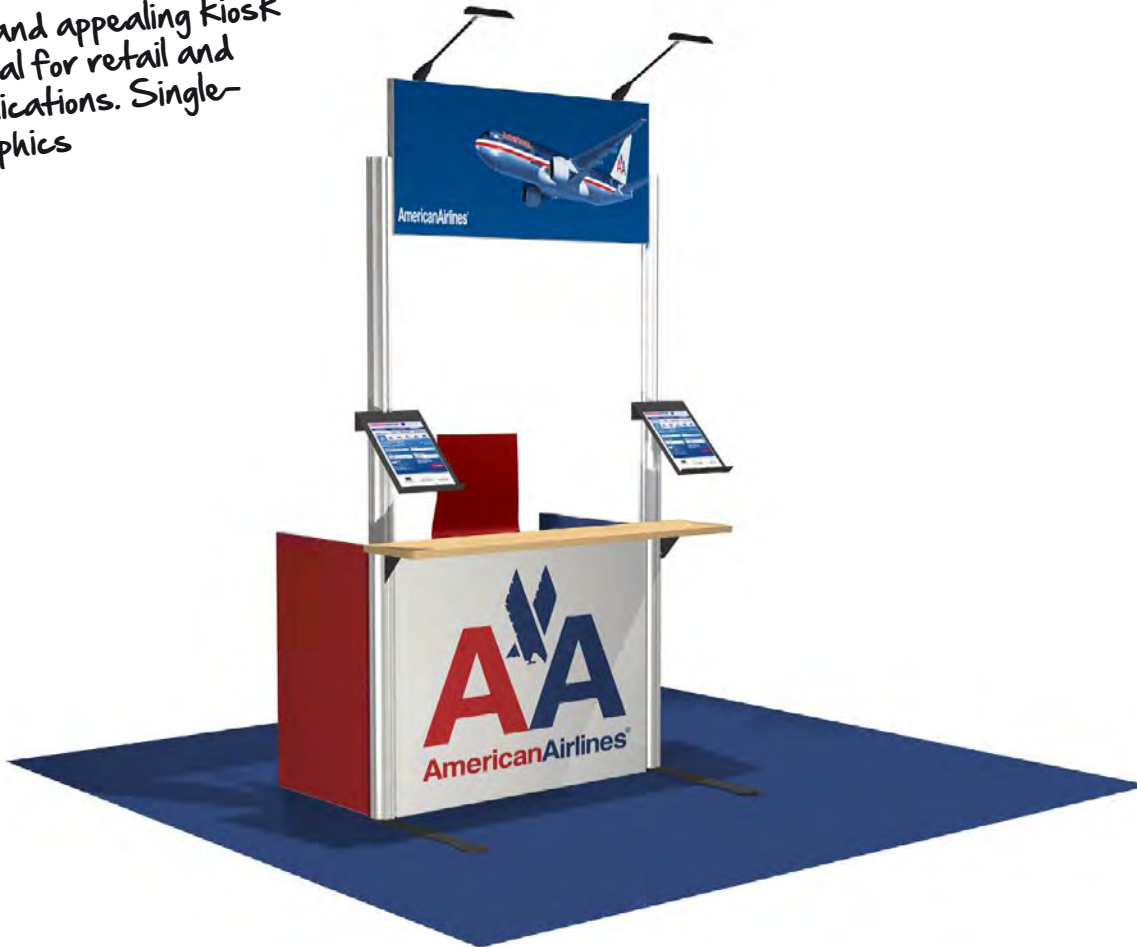

Hardware + Graphics

purchase* \$ **2,590**
 rental* \$ **1,290**

* chair not included

Product code:
MER-MOD-K6

Total Weight:
 95 lbs

storage area	
shelves	✓
billboard-style panel	✓
counter	✓
lights	✓
brochure holders	✓
monitor mount	

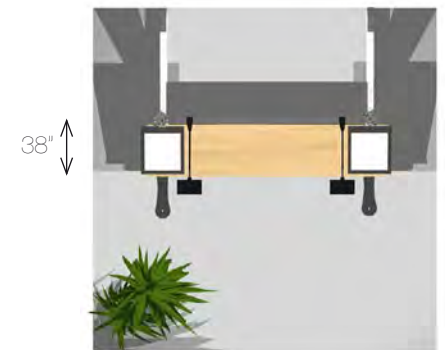

height 8'



brochure holders and countertop shelf



billboard-style panel & LED lights

Light Solutions



Additional Options



purchase* **\$90**

Product code:
LIGHT-50W-B OR
LIGHT-50W-S



purchase **\$100**

Product code:
LIGHT-200W



purchase **\$150**

Product code:
LIGHT-LED



Packaging Solutions

transport.

Additional Options



Rotomoulded Case with Wheels

purchase* \$ **275**

rental* \$ **175**

Product code:
MER-CASE-XL

Total Weight:
29 lbs



Custom Shipping Crate

purchase* \$ **1,583**

rental* \$ **600**

*dimensions will be customized according to booth size

Product code:
CUST-CRATE

Total Weight:
250 lbs

		quantity	
		rotomoulded case	or shipping crate
10 X 10	MER-10X10-K1	x 2	
	MER-10X10-K2	x 2	
	MER-10X10-K3	x 2	
	MER-10X10-K4	x 1	
	MER-10X10-K5	x 2	
	MER-10X10-K6	x 1	
10 X 20	MER-10X20-K1		x 1
	MER-10X20-K2	x 4	x 1
	MER-10X20-K3	x 4	x 1
	MER-10X20-K4	x 4	x 1
	MER-10X20-K5	x 3	x 1
	MER-10X20-K6	x 4	x 1
	MER-10X20-K7	x 4	x 1
MODULES	MER-MOD-K1	x 1	
	MER-MOD-K2	x 1	
	MER-MOD-K3	x 1	
	MER-MOD-K4	x 1	
	MER-MOD-K5	x 1	
	MER-MOD-K6	x 1	
	MER-MOD-K7	x 1	
	MER-MOD-K8	x 2	
	MER-MOD-K9	x 1	
	MER-MOD-K10	x 1	
	MER-MOD-K11	x 1	
	MER-MOD-K12	x 1	
	MER-MOD-K13	x 1	

Portable Solutions Comparison Guide

SOLUTIONS	Product code	Dimensions			Kit				Price/unit
		Height	Width	Weight	Counter	Shelves	Lights	Hard case	
All-In-One									
hello.set	DH2-K-SET	31.5"	96.88"	36 lbs (counter included)	X		Optional		\$1,491
hello.one	DH2-K-ONE	31.5"	79"	36 lbs (counter included)	X				\$1,328
hello.xpress									
HELLO-XPRESS		94"	96.75"	44 lbs	X	2	Optional	1	\$3,098
HELLO-XPRESS-A-1		94"	96.75"	44 lbs	x1	2		1	\$2,654
HELLO-XPRESS-B		94"	96.75"	44 lbs	x1	2		1	\$3,190
HELLO-XPRESS-D		94"	96.75"	44 lbs	x1	2		1	\$3,484
HELLO-XPRESS-10-EXTRA		Ideal for 10'x20'		44 lbs	x2	4		2	\$6,550
HELLO-XPRESS-20-B*		Ideal for 10'x20'		44 lbs	x2	4		2	\$8,105
Pop-Up									
xpressions.									
xpressions.4x3	KIT-XPR-4X3	89.5"	117.5"	15.5 lbs			Optional	Optional soft or hard case	\$3,576
xpressions.3x3	KIT-XPR-3X3A	94"	93.5"	12.5 lbs					\$2,450
xpressions.3x3	XPRESSIONS-3X3B	94"	93.5"	12.5 lbs		X			\$2,780
xpressions.2x3	KIT-XPR-2X3	94"	63"	9.5 lbs					\$1,750
xpressions.1x3	KIT-XPR-1X3	94"	32.25"	5.5 lbs		X			\$835
xpressions.pyramid xl	KIT-XPR-PYRAMID-XL	110"	178"	14.5 lbs					\$2,817
xpressions.pyramid S	KIT-XPR-PYRAMID	66"	90"	5.5 lbs					\$892
xpressions.argyle	KIT-XPR-ARGYLE-1	88"	133"	13 lbs					\$2,946
	KIT-XPR-ARGYLE-2	88"	133"	13 lbs					\$2,322
xpressions.cross	XPRESSIONS-CROSS	90"	90"	9 lbs					\$1,402
virage.									
virage.3x3	VIR-K-D33	88.2"	116.9"	30 lbs			X	Optional	\$1,098
virage.4x3	VIR-K-D33	88.2"	146.5"	47.4 lbs					\$1,363
blue.									
blue.3x3 curved	OB-S-R33CU-KIT	90.44"	96"	17.6 lbs	Optional		x2 200W Spotlights included	X	\$2,138
blue.4x3 curved	OB-S-R43CU-KIT	90.44"	119.31"	22.4 lbs	Optional				\$2,431
Tabletops									
blue.2x2	OB-S-R22CU-KIT	60.31"	70.5"	11 lbs			x2 50W Spotlights included		\$1,293
mercure.6x4	MER-TT-F16	4'	6'				x4 50W Spotlights included		\$998
set.600	SET-600-TT	Adjustable	24"						\$810

Booth Solutions Comparison Guide

		Product code	Kit						Price		
SOLUTIONS		Lights	Storage Area	Shelves	Billboard-style Panel	Counter	Brochure Holders	Monitor Mount	Purchase	Rental	
10'x10' Booths	MER-10x10-K6	2	X		X				\$ 3 990	\$ 2 690	
	MER-10x10-K4	4	X			X	X		\$ 4 790	\$ 2 880	
	MER-10x10-K2	2	X	X	X	X			\$ 6 065	\$ 3 230	
	MER-10x10-K5	-					X		\$ 6 490	\$ 4 790	
	MER-10x10-K1	2	X	X	X	X	X	X	\$ 6 880	\$ 3 410	
	MER-10x10-K3	2	X				X	X	\$ 8 920	\$ 5 100	
10'x20' Booths	MER-10x20-K6	3	X	X	X	X	X	X	\$ 7 990	\$ 5 645	
	MER-10x20-K5	5				X			\$ 8 990	\$ 5 170	
	MER-10x20-K7	3	X		X		X	X	\$ 9 490	\$ 6 240	
	MER-10x20-K3	3	X			X	X		\$ 10 250	\$ 6 390	
	MER-10x20-K2	3	X	X	X	X	X	X	\$ 11 410	\$ 5 880	
	MER-10x20-K4	3	x			X	x	X	\$ 11 900	\$ 7 540	
	MER-10x20-K1	4	X	X	X	X	X	X	\$ 12 290	\$ 6 060	
Modules	Banners	MER-MOD-K10				X			\$ 730	\$ 425	
		MER-MOD-K12			X	X		X	\$ 850	\$ 480	
		MER-MOD-K11				X		X	\$ 999	\$ 530	
		MER-MOD-K13				X			\$ 1 620	\$ 1 120	
	Counters	MER-MOD-K1				X			\$ 970	\$ 490	
		MER-MOD-K5		X	X	X	X		X	\$ 1 460	\$ 760
		MER-MOD-K2		X	X		X		\$ 1 490	\$ 850	
		MER-MOD-K4		X			X		\$ 1 720	\$ 1 020	
		MER-MOD-K3		X	X		X		\$ 1 990	\$ 1 090	
	Kiosks	MER-MOD-K8	X (optional)	X	X	X		X		\$ 3 200	\$ 1 560
		MER-MOD-K9			X	X		X		\$ 1 990	\$ 1 070
		MER-MOD-K7		X		X	X	X	X	\$ 2 295	\$ 1 120
MER-MOD-K6		X (optional)		X	X	X	X		\$ 2 590	\$ 1 290	

Preparation & Transmission of Art Files

- + Please be sure to follow the information in this booklet in order to help facilitate optimal production of your graphics within the allotted timeframe

Guidelines for File Preparation

- + **Templates**

Please use the templates provided by your account representative to design your art

- + **Accepted files formats**

Vectorized PDF or EPS files (please note! All fonts must be vectorized and the image links have to be incorporated)

High-res PDF image-files

- + **Images resolution**

Final size at 100 dpi or 300 dpi for a file at ¼ of final size

- + **Colors**

CMYK colors are preferred

RGB colors are not accepted

You can also provide us with the PMS references if you know them

For black-colored areas (wide format), we recommend reinforcing the black by 20% using 3 other colors

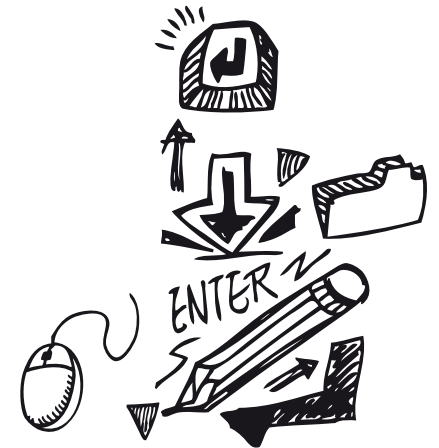

This information is given as a guide to help facilitate optimal print production. If these suggestions are not followed, the company cannot be responsible for the print quality. Should non-compliance with these guidelines necessitate the intervention of a designer or graphic tech specialist, all modification of original art files or additional orders could result in an additional invoice for your project

Trade Show Exhibiting:

show guide.

Tips and Tricks for Maximizing ROI

Exhibiting at a trade show is an extremely effective way of exposing your brand to the chief decision-makers in your field, and to plant the seeds necessary for meaningful, long-term client relationships. In fact, in 2010, 80 percent of all trade show attendees had “the power to recommend or make final purchasing decisions”, according to Exhibit Surveys, Inc. Moreover, “31 percent of attendees reported that their purchase intentions were more favorable after visiting companies’ exhibits”, a figure which clearly demonstrates the potential impact that your exhibit has on driving sales for your organization. Alas, trade shows cost money. Thus, the perennial question for trade show planning is: how can I maximize my return on investment (ROI)? While you are undoubtedly planning for the most influential element of your event, the exhibit itself, here are some tips and other points of consideration that will help you choose the best display for your organization’s needs while boosting ROI along the way



Trade Show Exhibiting:

Tips and Tricks for Maximizing ROI

Before the show

+ **How much space do you need?**

Choosing a small or medium-sized booth (10x10, 10x20) is one of the easiest ways to extend your show budget, but it does not have to mean less appeal for your exhibit. Stands that are 10x10 or 10x20 can be extremely effective as long as your message is well displayed. Make your booth a full visual system, completely devoted to your brand and images, and add lighting wherever possible in order to illuminate and draw attention

+ **How much time and how many people are required for set-up and dismantle?**

Hiring show labor for your booth can be cost prohibitive. If permitted, using your own personnel to put up the booth is a great cost-saving measure. In this case, easy to set-up banner stands, pop-up displays, and portable counters are great options. For modular systems, consider those that require little to no tools as well as systems that minimize the overall number of parts

+ **What is the weight of your exhibit, and what is the best way to transport it to the show?**

Transportation of your display materials is often one of the largest chunks of a trade show budget. It is important to plan your shipping in advance in order to maximize your savings. Request several quotes from different shippers or freight companies and ask if you qualify for discounts. Reducing the weight of your booth materials is also crucial. Portable display solutions such as pop-ups, fabric backwalls, banner stands, and retractables can be easily and inexpensively shipped with FedEx® and UPS®, or depending on their cases, can even be checked as airline baggage. In any case, fabric is the lightest and easiest graphic media for transportation to the show

+ **What on earth is drayage?**

Trade show drayage (aka material handling) involves the unloading, delivering, storing, and removing of exhibit properties as well as the fees associated with these services. Costs are generally calculated based on the weight of the items and their packaging. Average rates in 2011 were \$75 to \$120 per pound. To minimize the weight of your components, consider using fabric graphics instead of rigid panels as fabric is lightweight, wrinkle-resistant, and can easily fold up to pack small. When possible, choose display cases that are multi-functional, turning into a counter, kiosk, or storage space for your booth.

+ **What are you displaying at the show, and what accessories are required?**

Booth accessories are an awesome way to highlight your new products at the show. Remember to add shelves to your booth in order to present new additions to your line. If it is not practical to display your products on shelves, an interesting product video can add visual appeal to your stand. Monitor mount accessories allow you to attach TV monitors to bannerstands, modular booths, or even literature racks. Brochure racks can easily attach onto your display or be stand-alone items at the front of your booth, easy to reach for visitors to your stand

Tips and Tricks for Maximizing ROI

During the show

+ **Hide your junk!**

At a tradeshow, you want attendees to see your unique stand, your brand message, your products, and the smiling faces of your sales personnel, not extra boxes of brochures, bubble wrap, travel coffee mugs, and travel-worn purses and bags. Incorporating storage space into your booth is a great way to add varied depth and visual interest, while also covering all of the things you don't want prospective clients to see

+ **Stand in the spotlight!**

Lighted displays are four times more likely to be seen and noticed than those that do not include lights. With so many attractive and eco-friendly lighting options available, there is no reason not to brighten the look of your displays. Be sure to check on the regulations set forth by the venue and show organizers about lighting. LED technology is a great way to comply with these regulations while keeping a cool, eco-friendly booth and reducing the amount of electricity needed for your stand

+ **Illuminate your message!**

LED lighting provides the same amount of illumination and brightness as halogen lamps, for up to 1/20 of the wattage. In addition, LED backlighting is a great option to highlight one graphic or display, and it is the most effective way to add uniform colored lighting without visible lighting structures. This newest trend in exhibits provides that “magical” effect to your booth, entices attendees, and immediately grabs their attention

After the show

+ **Re-skin, remodel, reuse**

One of the best ways to maximize trade show ROI is to choose display solutions that are durable and long-lasting with repeat uses. Versatility is key. “Re-skinning” your booth with new graphics is a great way to reuse the same display components with a new message. Displays that feature easy to change graphics will assist you in saving time and money in these efforts. To “remodel” your booth, rearrange the components to provide a different look and feel. Besides reusing your booth at a show, certain components may be placed in an office lobby, a sales location, or taken out on sales appointments

+ **Follow Up!**

Don't throw dollar bills down the drain — attending a trade show is only worth the time and money invested if you conduct an effective show follow-up. After the show, debrief with your sales team and develop a detailed follow-up strategy to contact show leads via phone calls, e-mail blasts, and print literature

